



**MTB TECHNICAL MANUAL**

**EN 2 ES 67 DE 132 IT 197 FR 262**

---

## INDEX

<b>Introduction</b>	<b>4</b>
<b>Types of manual</b>	<b>5</b>
<b>Symbol legend</b>	<b>6</b>
<b>General warnings for the technical manual</b>	<b>7</b>
<b>Technical and mounting specifications for Oquo wheels</b>	<b>8</b>
OQUO MTB Wheel range table	8
Mountain Performance (MP)	9
MP30 LTD (up to MY2024)	9
MP30 LTD (from MY2025)	10
MP30 TEAM (up to MY2024)	11
MP30 TEAM (from MY2025)	12
MP28 PRO (up to MY2023)	13
MP28 PRO (from MY2024)	14
Mountain Control (MC)	15
MC32 LTD (up to MY2025)	15
MC32 LTD (from MY2026)	16
MC32 LTD POWER (up to MY2023)	17
MC32 LTD POWER (from MY2024)	18
MC32 TEAM (up to MY2024)	19
MC32 TEAM (MY2025)	20
MC32 TEAM (from MY2026)	21
MC32 TEAM RALLON DH MY2026 (OEM)	22
MC32 TEAM POWER (up to MY2023)	23
MC32 TEAM POWER (MY2024)	24
MC32 TEAM POWER (MY2025)	25
MC32 TEAM POWER (from MY2026)	26
<b>Maintenance of Oquo wheels</b>	<b>27</b>
Table of maintenance schedule	27
Tools	27
<b>Hub maintenance</b>	<b>33</b>
<b>Spare parts</b>	<b>35</b>
OQUO DT Swiss Inside hubs spare parts	35
Oquo DT Swiss Inside front hubs	35
Oquo LTD DT Swiss 240 Inside Straight Pull 15x110 24H Centerlock	35

Oquo TEAM DT Swiss 350 Inside Straight Pull 15x110 28H Centerlock/6-bolt	36
Oquo LTD DT Swiss 350 Inside J-bend 15x110 28H 6-bolt	37
Oquo DT Swiss Inside rear hubs	38
Oquo LTD DT Swiss 240 Inside Straight Pull 12x148 28H Centerlock	38
Oquo LTD DT Swiss 350 Inside Straight Pull 12x148 28/32H Centerlock/6-bolt	39
Oquo LTD DT Swiss Inside 350 DEG J-bend 12x148 32H 6-bolt	40
Spare parts for DT Swiss hubs	41
DT Swiss front hubs	41
DT Swiss 240 J-bend 15x110 24/28H Centerlock/6-bolt	41
DT Swiss 350 J-bend 15x110 28H Centerlock/6-bolt	42
DT Swiss 350 J-bend 20x110 28H 6-bolt	43
DT Swiss 370 J-bend 15x110 28H 6-bolt	44
DT Swiss 350 Hybrid J-bend 15x110 32H 6-bolt (up to MY2023)	45
DT Swiss 350 Hybrid J-bend 15x110 28H 6-bolt (from MY2024)	46
DT Swiss rear hubs	47
DT Swiss 240 J-bend 12x148 28H Centerlock	47
DT Swiss 350 J-bend 12x148 28/32H Centerlock/6-bolt	48
DT Swiss 370 J-bend 12x148 28H 6-bolt	49
DT Swiss 350 Hybrid J-bend 12x148 32H 6-bolt (up to MY2023)	50
DT Swiss 350 Hybrid J-bend 12x148 32H 6-bolt (from MY2024)	51
Spokes. Oquo wheel spoke kits	52
Oquo tubeless valves	56
<b>Oquo wheel construction</b>	<b>58</b>
<b>Additional information</b>	<b>66</b>

---

## INTRODUCTION

The information contained in this manual is primarily intended for OQUO distributors and users with some experience in wheel maintenance.

If, as a user, you do not have the knowledge to carry out the maintenance procedures described in this technical manual or install the spare parts listed, please take your wheels to an OQUO dealer for repair or maintenance.

You can find the contact information of our distributors on our website:

[www.oquowheels.com](http://www.oquowheels.com)

### NOTICE

---

Damage caused by improper maintenance or repair work is not covered by the warranty conditions.



Incorrect repairs, maintenance, or installation of components may affect the integrity and function of the wheels and could lead to accidents and serious injury or death.

---

## TYPES OF MANUAL

### TECHNICAL MANUAL

This manual details the specifications, maintenance procedures and original spare parts for OQUO products and is aimed at specialised distributors or users with the necessary skills.

The maintenance procedures for third-party components on our wheels are referenced through links to the manufacturer's own documentation.

The processes, specifications and spare parts described in this manual are subject to changes in our product specifications.

The latest version of this technical manual is available on the OQUO website.

### USER MANUAL

To access the user manual for our wheels, which details information on the correct use of the wheels, warnings for use, transport and storage, installation, etc., please consult the user manual on our website.

You can access all product documentation, as well as relevant warranty information and service programmes on our website:

[www.oquowheels.com/es-es/soporte/manuales](http://www.oquowheels.com/es-es/soporte/manuales)

---

## SYMBOL LEGEND

Throughout this manual various symbols are used to detail instructions, warnings or relevant information on use, maintenance and assembly. Pay attention to these symbols to avoid dangerous situations and to ensure the correct use and assembly of all components.

The meaning of these symbols is explained below. In this manual, the symbol may be accompanied only by the relevant instruction for the component it describes. Read the following information carefully to understand its meaning.

### SAFETY INSTRUCTIONS



---

**DANGER:** Dangerous situation which, if not avoided, will result in serious injury or death



---

**WARNING:** Dangerous situation which, if not avoided, could result in serious injury or death.



---

**CAUTION:** Dangerous situation which, if not avoided, may result in minor or moderate injury.

### NOTICE

---

Situation not related to physical injury. Relevant information.

The symbols DANGER and WARNING always imply a risk of accident if measures are not taken to avoid the situation they describe. An accident while riding a bicycle can always involve a risk of serious injury or even death. The risk of death will not always be repeated in this manual when these symbols appear, as the risk is detailed here.

### TOOLS

Always use the right tools and products for a specific maintenance or repair operation. Unsuitable or poorly maintained tools, or the use of generic products, may cause damage to components that are not then covered by the warranty conditions.

The tools to be used are specified in this manual, or reference is made to the maintenance manuals of the manufacturers of components used on our wheels, where the appropriate tools are detailed.

---

## GENERAL WARNINGS FOR THE TECHNICAL MANUAL

- For installation instructions, maintenance and warnings about the use of third-party components on our wheels, such as brake rotors, cassettes, tyres, etc. please refer to the component manufacturer's documentation.
- Keep all parts of your body and/or clothing away from the brake rotors or spokes during use or adjustment to avoid serious cuts and injuries.
- As a general rule, clean all components during maintenance or service before reinstalling them.
- Keep the wheels and their components clean and free of foreign objects to ensure their proper functioning and to be able to assess their condition.
- Always use a soft cloth and specific cleaning products to clean your wheels and components.
- Do not use pressurised water or aggressive chemicals to clean wheels and wheel components. Pressurised water can dilute lubricants, shortening the life of the lubricants and/or causing damage not covered by the warranty conditions.

### SPARE PARTS

Use only original OQUO spare parts or those referenced in this manual or in the component manufacturer's documentation.

#### NOTICE

---

The use of non-original spare parts may result in damage to components which is not covered by the warranty conditions.



The use of non-original spare parts can cause component failure, which can lead to accidents and serious injuries.

## TECHNICAL AND MOUNTING SPECIFICATIONS FOR OQUO WHEELS

The following tables describe in detail the component and assembly specifications for all OQUO MTB models.

Data from these tables is referenced throughout this manual, where relevant to specific sections. Consult these tables to find the data you are looking for.

### OQUO MTB WHEEL RANGE TABLE

	FAMILY	MODEL	CATEGORY
MTB	MOUNTAIN PERFORMANCE (MP)	MP30LTD	XC, MARATHON, TRAIL
		MP30TEAM	
		MP28PRO	
	MOUNTAIN CONTROL (MC)	MC32LTD	TRAIL, ENDURO, GRAVITY
		MC32LTD POWER	E-ENDURO, GRAVITY
		MC32TEAM	TRAIL, ENDURO, GRAVITY
		MC32TEAM POWER	E-ENDURO, GRAVITY

MOUNTAIN PERFORMANCE (MP)

MP30 LTD (up to MY2024)

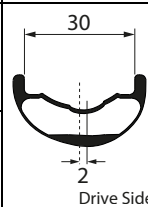
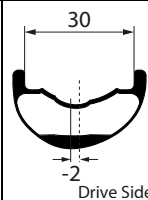
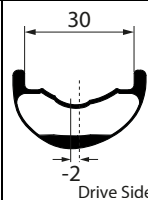
	MODEL	MATERIAL	SIZE	RIM TYPE	BRAKE TYPE	TUBELESS	INNER WIDTH	OFFSET	DIRECTIONAL SPOKE HOLES	SPOKE HOLES	ERD	ETRTO	JOINT	TUBELESS TAPE WIDTH	VALVE	COMPATIBLE TYRES	MAXIMUM PRESSURE	SECTION	
RIMS	FRONT RIM (28H)	MP10-F-29-28H	Carbon	29"	Clincher Hookless	Disc	YES	30 mm	2 mm	YES	28	611 mm	622x30TSS	—	30 mm	44 mm	2.05"-2.8"	**	
	FRONT RIM (24H)	MP11-F-29-24H	Carbon	29"	Clincher Hookless	Disc	YES	30 mm	2 mm	YES	24	611 mm	622x30TSS	—	30 mm	44 mm	2.05"-2.8"	**	
	REAR RIM	MP10-R-29-28H	Carbon	29"	Clincher Hookless	Disc	YES	30 mm	-2 mm	YES	28	607.6 mm	622x30TSS	—	30 mm	44 mm	2.05"-2.8"	**	

	No. SPOKES	MODEL	DRIVE SIDE SPOKE PATTERN	NON-DRIVE SIDE SPOKE PATTERN	DRIVE SIDE SPOKE LENGTH	NON-DRIVE SIDE SPOKE LENGTH	DRIVE SIDE ASSEMBLY TENSION	DISC SIDE ASSEMBLY TENSION	LEADING SPOKE DRIVE SIDE	TRAILING SPOKE DRIVE SIDE	LEADING SPOKE NON-DRIVE SIDE	TRAILING SPOKE NON-DRIVE SIDE
SPOKES	FRONT (28H)	Sapim CX-Ray TCS Aero 14G (2 mm) J-Bend	3 Cross	3 Cross	299 mm	297 mm	—	1200 N	Outside	Inside	Outside	Inside
	FRONT (24H)	Sapim CX-Ray TCS Aero 14G (2 mm) J-Bend	3 Cross	3 Cross	293 mm	291 mm	—	1200 N	Outside	Inside	Outside	Inside
	REAR	Sapim CX-Ray TCS Aero 14G (2 mm) J-Bend	3 Cross	3 Cross	295 mm	296 mm	1300 N	—	Inside	Outside	Outside	Inside

HUB	MODEL	SPACING (OLD)	AXLE	DISC TYPE	SPOKES	FREEHUB BODY	FREEHUB MECHANISM	NIPPLES	MODEL	MEASUREMENTS	SPOKE NIPPLE WASHERS	WEIGHT	WHEEL	WEIGHT	USE		
	FRONT HUB (28H)	DT SWISS 240 Classic CL	Boost 110 mm	Thru axle 15mm	Centre Lock	28 J-Bend	—		—	FRONT (28H)	Sapim Alloy Double Square		2x18 mm (14G)	No		FRONT (28H)	625gr +/-5%
	FRONT HUB (24H)	DT SWISS 240 Classic CL	Boost 110 mm	Thru axle 15mm	Centre Lock	24 J-Bend	—		—	FRONT (24H)	Sapim Alloy Double Square		2x18 mm (14G)	No		FRONT (24H)	591gr +/-5%
REAR HUB	DT SWISS 240 Classic CL	Boost 148 mm	Thru axle 12 mm	Centre Lock	28 J-Bend	Sram XD or Shimano Microspline	Ratchet EXP 36	REAR	Sapim Alloy Double Square	2x18 mm (14G)	No	REAR	730gr +/-5%				

\*\* For the maximum tyre pressure, refer to the owner's manual or the decal on the wheel itself.

[Click or tap on the hub or spoke model to access spare parts information](#)

**ASTM Condition 3**  
(See user manual)  
Maximum weight of the system (bicycle + cyclist + equipment) = **110 kg.**

MOUNTAIN PERFORMANCE (MP)

MP30 LTD (from MY2025)

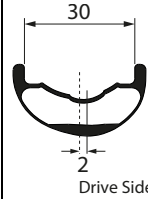
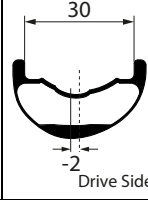
	MODEL	MATERIAL	SIZE	RIM TYPE	BRAKE TYPE	TUBELESS	INNER WIDTH	OFFSET	DIRECTIONAL SPOKE HOLES	SPOKE HOLES	ERD	ETRTO	JOINT	TUBELESS TAPE WIDTH	VALVE	COMPATIBLE TYRES	MAXIMUM PRESSURE	SECTION	
RIMS	FRONT RIM	MP11-F-29-24H	Carbon	29"	Clincher Hookless	Disc	YES	30 mm	2 mm	YES	24	601 mm	622x30TSS	—	30 mm	44 mm	2.05"-2.8"	**	
	REAR RIM	MP10-R-29-28H	Carbon	29"	Clincher Hookless	Disc	YES	30 mm	-2 mm	YES	28	599 mm	622x30TSS	—	30 mm	44 mm	2.05"-2.8"	**	

	No. SPOKES	MODEL	DRIVE SIDE SPOKE PATTERN	NON-DRIVE SIDE SPOKE PATTERN	DRIVE SIDE SPOKE LENGTH	NON-DRIVE SIDE SPOKE LENGTH	DRIVE SIDE ASSEMBLY TENSION	DISC SIDE ASSEMBLY TENSION	
SPOKES	FRONT (24H)	24	DT aerolite T-shape SP* 2.0-(0.9x2.2)-2mm	2 Cross	2 Cross	301 mm	301 mm	—	1200 N
	REAR	28	DT aerolite T-shape SP* 2.0-(0.9x2.2)-2mm	3 Cross	3 Cross	304 mm	304 mm	1300 N	—

HUB	MODEL	SPACING (OLD)	AXLE	DISC TYPE	SPOKES	FREEHUB BODY	FREEHUB MECHANISM	NIPPLES	MODEL	MEASUREMENTS	SPOKE NIPPLE WASHERS	WEIGHT	WHEEL	USE
	FRONT HUB	OQUO LTD DT 240 INSIDE	Boost 110 mm	Thru axle 15mm	Centre Lock	24 SP*	—		—	FRONT	DT Alloy Double Square		2x15 mm (FG 2,3)	
REAR HUB	OQUO LTD DT 240 INSIDE	Boost 148 mm	Thru axle 12 mm	Centre Lock	28 SP*	Sram XD or SP Shimano Microspline	DT Swiss Ratchet EXP 10° / 36	REAR	DT Alloy Double Square	2x15 mm (FG 2,3)	No	REAR	740g +/-5%	

\* SP: Straightpull

\*\* For the maximum tyre pressure, refer to the owner's manual or the decal on the wheel itself.

[Click or tap on the hub or spoke model to access spare parts information](#)

MOUNTAIN PERFORMANCE (MP)

MP30 TEAM (up to MY2024)

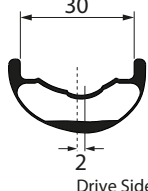
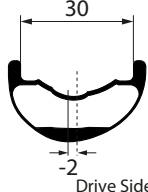
RIMS		MODEL	MATERIAL	SIZE	RIM TYPE	BRAKE TYPE	TUBELESS	INNER WIDTH	OFFSET	DIRECTIONAL SPOKE HOLES	SPOKE HOLES	ERD	ETRTO	JOINT	TUBELESS TAPE WIDTH	VALVE	COMPATIBLE TYRES	MAXIMUM PRESSURE	SECTION
	FRONT RIM	MP10-F-29-28H	Carbon	29"	Clincher Hookless	Disc	YES	30 mm	2 mm	YES	28	611 mm	622x30TSS	—	30 mm	44 mm	2.05"-2.8"	**	
REAR RIM	MP10-R-29-28H	Carbon	29"	Clincher Hookless	Disc	YES	30 mm	-2 mm	YES	28	607.6 mm	622x30TSS	—	30 mm	44 mm	2.05"-2.8"	**		

SPOKES		No. SPOKES	MODEL	DRIVE SIDE SPOKE PATTERN	NON-DRIVE SIDE SPOKE PATTERN	DRIVE SIDE SPOKE LENGTH	NON-DRIVE SIDE SPOKE LENGTH	DRIVE SIDE ASSEMBLY TENSION	DISC SIDE ASSEMBLY TENSION	LEADING SPOKE DRIVE SIDE	TRAILING SPOKE DRIVE SIDE	LEADING SPOKE NON-DRIVE SIDE	TRAILING SPOKE NON-DRIVE SIDE
	FRONT	28	Sapim D-Sprint Butted 14G (2 mm) J-Bend	3 Cross	3 Cross	298 mm	297 mm	—	1200 N	Outside	Inside	Outside	Inside
REAR	28	Sapim D-Sprint Butted 14G (2 mm) J-Bend	3 Cross	3 Cross	294 mm	295 mm	1300 N	—	Inside	Outside	Outside	Inside	

HUB		MODEL	SPACING (OLD)	AXLE	DISC TYPE	SPOKES	FREEHUB BODY	FREEHUB MECHANISM
	FRONT HUB	DT SWISS 350 Classic CL	Boost 110 mm	Thru axle 15mm	Centre Lock	28 J-Bend	—	—
REAR HUB	DT SWISS 350 Classic CL	Boost 148 mm	Thru axle 12 mm	Centre Lock	28 J-Bend	Sram XD or Shimano Microspline	Ratchet 36	

NIPPLES		MODEL	MEASUREMENTS	SPOKE NIPPLE WASHERS
	FRONT	Sapim Brass Polyax	2x14 mm (14G)	No
REAR	Sapim Brass Polyax	2x14 mm (14G)	No	

WEIGHT		WHEEL	WEIGHT
	FRONT	700gr +/-5%	
REAR	830gr +/-5%		

**USE**

**ASTM Condition 3**  
(See user manual)

Maximum weight of the system (bicycle + cyclist + equipment) = **110 kg.**

\*\* For the maximum tyre pressure, refer to the owner's manual or the decal on the wheel itself.

[Click or tap on the hub or spoke model to access spare parts information](#)

MOUNTAIN PERFORMANCE (MP)

MP30 TEAM (from MY2025)

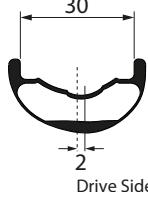
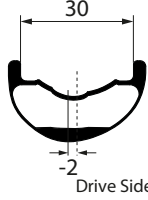
RIMS		MODEL	MATERIAL	SIZE	RIM TYPE	BRAKE TYPE	TUBELESS	INNER WIDTH	OFFSET	DIRECTIONAL SPOKE HOLES	SPOKE HOLES	ERD	ETRTO	JOINT	TUBELESS TAPE WIDTH	VALVE	COMPATIBLE TYRES	MAXIMUM PRESSURE	SECTION
	FRONT RIM	MP10-F-29-28H	Carbon	29"	Clincher Hookless	Disc	YES	30 mm	2 mm	YES	28	611 mm	622x30TSS	—	30 mm	44 mm	2.05"-2.8"	**	
REAR RIM	MP10-R-29-28H	Carbon	29"	Clincher Hookless	Disc	YES	30 mm	-2 mm	YES	28	607.6 mm	622x30TSS	—	30 mm	44 mm	2.05"-2.8"	**		

SPOKES		No. SPOKES	MODEL	DRIVE SIDE SPOKE PATTERN	NON-DRIVE SIDE SPOKE PATTERN	DRIVE SIDE SPOKE LENGTH	NON-DRIVE SIDE SPOKE LENGTH	DRIVE SIDE ASSEMBLY TENSION	DISC SIDE ASSEMBLY TENSION
	FRONT	28	<a href="#">Sapim Sprint SP* Butted 2.0/1.7/2.0</a>	3 Cross	3 Cross	305 mm	305 mm	—	1200 N
	REAR	28	<a href="#">Sapim Sprint SP* Butted 2.0/1.7/2.0</a>	3 Cross	3 Cross	303 mm	303 mm	1300 N	—

HUB		MODEL	SPACING (OLD)	AXLE	DISC TYPE	SPOKES	FREEHUB BODY	FREEHUB MECHANISM	NIPPLES		MODEL	MEASUREMENTS	SPOKE NIPPLE WASHERS	WEIGHT	WHEEL	WEIGHT	USE
	FRONT HUB	<a href="#">OQUO TEAM DT 350 INSIDE</a>	Boost 110 mm	Thru axle 15mm	Centre Lock	28 SP*	—	—		FRONT	Sapim Alloy Double Square	2x18 mm (14G)	No		FRONT	695g +/-5%	
REAR HUB	<a href="#">OQUO TEAM DT 350 INSIDE</a>	Boost 148 mm	Thru axle 12 mm	Centre Lock	28 SP*	Sram XD or Shimano Microspline	DT Swiss Ratchet 10°/36	REAR	Sapim Alloy Double Square	2x18 mm (14G)	No	REAR	810g +/-5%				

\* SP: Straightpull

\*\* For the maximum tyre pressure, refer to the owner's manual or the decal on the wheel itself.

[Click or tap on the hub or spoke model to access spare parts information](#)

**ASTM Condition 4**  
(See user manual)  
Maximum weight of the system  
(bicycle + cyclist + equipment)  
= **110 kg.**

MOUNTAIN PERFORMANCE (MP)

MP28 PRO (up to MY2023)

RIMS		MODEL	MATERIAL	SIZE	RIM TYPE	BRAKE TYPE	TUBELESS	INNER WIDTH	OFFSET	DIRECTIONAL SPOKE HOLES	SPOKE HOLES	ERD	ETRTO	JOINT	TUBELESS TAPE WIDTH	VALVE	COMPATIBLE TYRES	MAXIMUM PRESSURE	SECTION
	FRONT/REAR		MP30-B-29-28H	Aluminium AL6061	29"	Clincher Hookless	Disc	YES	28 mm	2 mm	YES	28	600 mm	622x28TSS	Sleeved	28 mm	40 mm	2"-2.55"	**

SPOKES		No. SPOKES	MODEL	DRIVE SIDE SPOKE PATTERN	NON-DRIVE SIDE SPOKE PATTERN	DRIVE SIDE SPOKE LENGTH	NON-DRIVE SIDE SPOKE LENGTH	DRIVE SIDE ASSEMBLY TENSION	DISC SIDE ASSEMBLY TENSION	LEADING SPOKE DRIVE SIDE	TRAILING SPOKE DRIVE SIDE	LEADING SPOKE NON-DRIVE SIDE	TRAILING SPOKE NON-DRIVE SIDE
	FRONT		28	Sapim Race Butted 14G (2 mm) J-Bend	3 Cross	3 Cross	298 mm	297 mm	—	1200 N	Outside	Inside	Outside
REAR		28	Sapim Race Butted 14G (2 mm) J-Bend	3 Cross	3 Cross	296 mm	297 mm	1200 N	—	Inside	Outside	Outside	Inside

HUB		MODEL	SPACING (OLD)	AXLE	DISC TYPE	SPOKES	FREEHUB BODY	FREEHUB MECHANISM
	FRONT HUB		DT SWISS 350 Classic CL	Boost 110 mm	Thru axle 15mm	Centre Lock	28 J-Bend	—
REAR HUB		DT SWISS 350 Classic CL	Boost 148 mm	Thru axle 12 mm	Centre Lock	28 J-Bend	Sram XD Shimano Microspline Shimano HG	Ratchet 36

NIPPLES		MODEL	MEASUREMENTS	SPOKE NIPPLE WASHERS
	FRONT		Sapim Brass Polyax	2x14 mm (14G)
REAR		Sapim Brass Polyax	2x14 mm (14G)	No

WEIGHT		WHEEL	WEIGHT
	FRONT		FRONT
REAR		REAR	955gr +/-5%

**USE**

**ASTM Condition 4**  
(See user manual)

Maximum weight of the system  
(bicycle + cyclist + equipment)  
= **110 kg.**

\*\* For the maximum tyre pressure, refer to the owner's manual or the decal on the wheel itself.

[Click or tap on the hub or spoke model to access spare parts information](#)

MOUNTAIN PERFORMANCE (MP)

MP28 PRO (from MY2024)

	MODEL	MATERIAL	SIZE	RIM TYPE	BRAKE TYPE	TUBELESS	INNER WIDTH	OFFSET	DIRECTIONAL SPOKE HOLES	SPOKE HOLES	ERD	ETRTO	JOINT	TUBELESS TAPE WIDTH	VALVE	COMPATIBLE TYRES	MAXIMUM PRESSURE	SECTION	
RIMS	FRONT/ REAR	MP31-B-29-28H	Aluminium AL6061	29"	Clincher Hookless	Disc	YES	28 mm	2 mm	YES	28	600 mm	622x28TSS	Sleeved	28 mm	40 mm	2"-2.55"	**	

	No. SPOKES	MODEL	DRIVE SIDE SPOKE PATTERN	NON-DRIVE SIDE SPOKE PATTERN	DRIVE SIDE SPOKE LENGTH	NON-DRIVE SIDE SPOKE LENGTH	DRIVE SIDE ASSEMBLY TENSION	DISC SIDE ASSEMBLY TENSION	LEADING SPOKE DRIVE SIDE	TRAILING SPOKE DRIVE SIDE	LEADING SPOKE NON-DRIVE SIDE	TRAILING SPOKE NON-DRIVE SIDE	
SPOKES	FRONT	28	Sapim Race Butted 14G (2 mm) J-Bend	3 Cross	3 Cross	297 mm	296 mm	—	1200 N	Outside	Inside	Outside	Inside
	REAR	28	Sapim Race Butted 14G (2 mm) J-Bend	3 Cross	3 Cross	296 mm	296 mm	1200 N	—	Inside	Outside	Outside	Inside

	MODEL	SPACING (OLD)	AXLE	DISC TYPE	SPOKES	FREEHUB BODY	FREEHUB MECHANISM		MODEL	MEASUREMENTS	SPOKE NIPPLE WASHERS		WHEEL	WEIGHT			
HUB	FRONT HUB	DT SWISS 370 Classic IS	Boost 110 mm	Thru axle 15mm	6-Bolt	28 J-Bend	—		NIPPLES	FRONT	Sapim Brass Polyax	2x14 mm (14G)	No	WEIGHT	FRONT	890gr +/-5%	<b>USE</b> <b>ASTM Condition 4</b> (See user manual) Maximum weight of the system (bicycle + cyclist + equipment) = <b>110 kg.</b>
	REAR HUB	DT SWISS 370 Classic IS	Boost 110 mm	Thru axle 15mm	6-Bolt	28 J-Bend	Sram XD Shimano Microspline	Ratchet LN 18		REAR	Sapim Brass Polyax	2x14 mm (14G)	No		REAR	1040gr +/-5%	

\*\* For the maximum tyre pressure, refer to the owner's manual or the decal on the wheel itself.

[Click or tap on the hub or spoke model to access spare parts information](#)

MOUNTAIN CONTROL (MC)

MC32 LTD (up to MY2025)

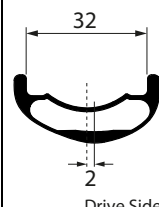
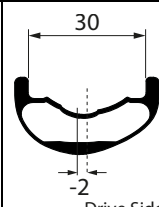
	MODEL	MATERIAL	SIZE	RIM TYPE	BRAKE TYPE	TUBELESS	INNER WIDTH	OFFSET	DIRECTIONAL SPOKE HOLES	SPOKE HOLES	ERD	ETRTO	JOINT	TUBELESS TAPE WIDTH	VALVE	COMPATIBLE TYRES	MAXIMUM PRESSURE	SECTION	
RIMS	FRONT RIM	MC10-F-29-28H	Carbon	29"	Clincher Hookless	Disc	YES	32 mm	2 mm	YES	28	604.26 mm	622x32TSS	—	32 mm	44 mm	2.4"-2.8"	**	
	REAR RIM	MC10-R-29-32H	Carbon	29"	Clincher Hookless	Disc	YES	30 mm	-2 mm	YES	32	599.86 mm	622x30TSS	—	30 mm	44 mm 57 mm on Wild with magnet in valve	2.05"-2.8"	**	

	No. SPOKES	MODEL	DRIVE SIDE SPOKE PATTERN	NON-DRIVE SIDE SPOKE PATTERN	DRIVE SIDE SPOKE LENGTH	NON-DRIVE SIDE SPOKE LENGTH	DRIVE SIDE ASSEMBLY TENSION	DISC SIDE ASSEMBLY TENSION	LEADING SPOKE DRIVE SIDE	TRAILING SPOKE DRIVE SIDE	LEADING SPOKE NON-DRIVE SIDE	TRAILING SPOKE NON-DRIVE SIDE
FRONT	28	Sapim D-Sprint Butted, 14G (2 mm) J-Bend	3 Cross	3 Cross	301 mm	298 mm	—	1200 N	Outside	Inside	Outside	Inside
REAR	32	Sapim D-Sprint Butted, 14G (2 mm) J-Bend	3 Cross	3 Cross	292 mm	292 mm	1300 N	—	Inside	Outside	Outside	Inside

HUB	MODEL	SPACING (OLD)	AXLE	DISC TYPE	SPOKES	FREEHUB BODY	FREEHUB MECHANISM	NIPPLES	MODEL	MEASUREMENTS	SPOKE NIPPLE WASHERS	WEIGHT	WHEEL	USE
	FRONT HUB	DT SWISS 350 Classic IS	Boost 110 mm	Thru axle 15mm	6-Bolt	28 J-Bend	—		—	FRONT	Sapim Brass Polyax			
REAR HUB	DT SWISS 350 Classic IS	Boost 148 mm	Thru axle 12mm	6-Bolt	32J-Bend	Sram XD Shimano MS	Ratchet 36	REAR	Sapim Brass Polyax	2x14 mm (14G)	No	REAR	1042gr +/-5%	

\*\* For the maximum tyre pressure, refer to the owner's manual or the decal on the wheel itself.

[Click or tap on the hub or spoke model to access spare parts information](#)

MOUNTAIN CONTROL (MC)

MC32 LTD (from MY2026)

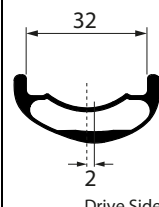
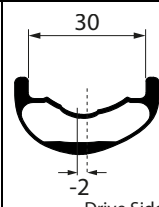
	MODEL	MATERIAL	SIZE	RIM TYPE	BRAKE TYPE	TUBELESS	INNER WIDTH	OFFSET	DIRECTIONAL SPOKE HOLES	SPOKE HOLES	ERD	ETRTO	JOINT	TUBELESS TAPE WIDTH	VALVE	COMPATIBLE TYRES	MAXIMUM PRESSURE	SECTION	
RIMS	FRONT RIM	MC10-F-29-28H	Carbon	29"	Clincher Hookless	Disc	YES	32 mm	2 mm	YES	28	604.26 mm	622x32TSS	—	32 mm	44 mm	2.4"-2.8"	**	
	REAR RIM	MC10-R-29-32H	Carbon	29"	Clincher Hookless	Disc	YES	30 mm	-2 mm	YES	32	599.86 mm	622x30TSS	—	30 mm	44 mm 57 mm on Wild with magnet in valve	2.05"-2.8"	**	

	No. SPOKES	MODEL	DRIVE SIDE SPOKE PATTERN	NON-DRIVE SIDE SPOKE PATTERN	DRIVE SIDE SPOKE LENGTH	NON-DRIVE SIDE SPOKE LENGTH	DRIVE SIDE ASSEMBLY TENSION	DISC SIDE ASSEMBLY TENSION	LEADING SPOKE DRIVE SIDE	TRAILING SPOKE DRIVE SIDE	LEADING SPOKE NON-DRIVE SIDE	TRAILING SPOKE NON-DRIVE SIDE
FRONT	28	Sapim Sprint Butted, 14G (2 mm) J-Bend	3 Cross	3 Cross	299 mm	299 mm	—	1200 N	Outside	Inside	Outside	Inside
REAR	32	Sapim Race Butted, 14G (2 mm) J-Bend	3 Cross	3 Cross	291 mm	291 mm	1300 N	—	Inside	Outside	Outside	Inside

HUB	MODEL	SPACING (OLD)	AXLE	DISC TYPE	SPOKES	FREEHUB BODY	FREEHUB MECHANISM	NIPPLES	MODEL	MEASUREMENTS	SPOKE NIPPLE WASHERS	WEIGHT	WHEEL	USE
	FRONT HUB	OQUO LTD DT 350 INSIDE	Boost 110 mm	Thru axle 15mm	6-Bolt	28 J-Bend	—		—	FRONT	Sapim Brass Polyax		2x14 mm (14G)	
REAR HUB	OQUO LTD DT 350 DEG INSIDE	Boost 148 mm	Thru axle 12mm	6-Bolt	32 J-Bend	Sram XD Shimano MS	Ratchet DEG 72	REAR	Sapim Brass Polyax	2x14 mm (14G)	No	REAR	1042gr +/-5%	

**ASTM Condition 5**  
(See user manual)  
Maximum weight of the system  
(bicycle + cyclist + equipment)  
= **135 kg.**

\*\* For the maximum tyre pressure, refer to the owner's manual or the decal on the wheel itself.

[Click or tap on the hub or spoke model to access spare parts information](#)

**MOUNTAIN CONTROL (MC)**

**MC32 LTD POWER (up to MY2023)**

RIMS	MODEL	MATERIAL	SIZE	RIM TYPE	BRAKE TYPE	TUBELESS	INTERNAL WIDTH	OFFSET	DIRECTIONAL SPOKE HOLES	SPOKE HOLES	ERD	ETRTO	JOINT	TUBELESS TAPE WIDTH	VALVE	COMPATIBLE TYRES	MAXIMUM PRESSURE	SECTION
	REAR RIM	MC10-R-29-32H	Carbon	29"	Clincher Hookless	Disc	YES	30 mm	-2 mm	YES	32	599.86 mm	622x30TSS	—	30 mm	44 mm 57 mm on Wild with magnet in valve	2.05"-2.8"	**

SPOKES	No. SPOKES	MODEL	DRIVE SIDE SPOKE PATTERN	NON-DRIVE SIDE SPOKE PATTERN	DRIVE SIDE SPOKE LENGTH	NON-DRIVE SIDE SPOKE LENGTH	DRIVE SIDE ASSEMBLY TENSION	DISC SIDE ASSEMBLY TENSION	LEADING SPOKE DRIVE SIDE	TRAILING SPOKE DRIVE SIDE	LEADING SPOKE NON-DRIVE SIDE	TRAILING SPOKE NON-DRIVE SIDE
	REAR	32	Sapim E-Light. Butted 14G (2 mm) J-Bend	3 Cross	3 Cross	292 mm	294 mm	1300 N	—	Inside	Outside	Outside

HUB	MODEL	SPACING (OLD)	AXLE	DISC TYPE	SPOKES	FREEHUB BODY	FREEHUB MECHANISM	NIPPLES	MODEL	MEASUREMENTS	SPOKE NIPPLE WASHERS	WEIGHT	WHEEL	WEIGHT	USE
	REAR HUB	DT SWISS 350 Hybrid Classic IS model up to MY2023	Boost 148 mm	Thru axle 12mm	6-Bolt	32	Sram XD Shimano MS		Ratchet 24	REAR	Sapim Brass Polyax		2x14 mm (14G)	No	

\*\* For the maximum tyre pressure, refer to the owner's manual or the decal on the wheel itself.

[Click or tap on the hub or spoke model to access spare parts information](#)

MOUNTAIN CONTROL (MC)

MC32 LTD POWER (from MY2024)

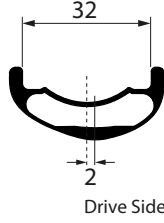
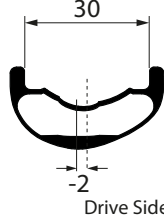
RIMS		MODEL	MATERIAL	SIZE	RIM TYPE	BRAKE TYPE	TUBELESS	INTERNAL WIDTH	OFFSET	DIRECTIONAL SPOKE HOLES	SPOKE HOLES	ERD	ETRTO	JOINT	TUBELESS TAPE WIDTH	VALVE	COMPATIBLE TYRES	MAXIMUM PRESSURE	SECTION
	FRONT RIM	MC10-F-29-28H	Carbon	29"	Clincher Hookless	Disc	YES	32 mm	2 mm	YES	28	604.26 mm	622x32TSS	—	32 mm	44 mm	2.4"-2.8"	**	
REAR RIM	MC10-R-29-32H	Carbon	29"	Clincher Hookless	Disc	YES	30 mm	-2 mm	YES	32	599.86 mm	622x30TSS	—	30 mm	44 mm 57 mm on Wild with magnet in valve	2.05"-2.8"	**b		

SPOKES		No. SPOKES	MODEL	DRIVE SIDE SPOKE PATTERN	NON-DRIVE SIDE SPOKE PATTERN	DRIVE SIDE SPOKE LENGTH	NON-DRIVE SIDE SPOKE LENGTH	DRIVE SIDE ASSEMBLY TENSION	DISC SIDE ASSEMBLY TENSION	LEADING SPOKE DRIVE SIDE	TRAILING SPOKE DRIVE SIDE	LEADING SPOKE NON-DRIVE SIDE	TRAILING SPOKE NON-DRIVE SIDE
	FRONT		28	Sapim E-Light, Butted 14G (2 mm) J-Bend	3 Cross	3 Cross	299 mm	298 mm	—	1300 N	Outside	Inside	Outside
REAR		32	Sapim E-Light, Butted 14G (2 mm) J-Bend	3 Cross	3 Cross	291 mm	292 mm	1300 N	—	Inside	Outside	Outside	Inside

HUB		MODEL	SPACING (OLD)	AXLE	DISC TYPE	SPOKES	FREEHUB BODY	FREEHUB MECHANISM	NIPPLES		MODEL	MEASUREMENTS	SPOKE NIPPLE WASHERS	WEIGHT	WHEEL	WEIGHT	USE
	FRONT HUB		DT SWISS 350 Hybrid Classic IS model from MY2024	Boost 110 mm	Thru axle 15mm	6-Bolt	28	—		—	FRONT	Sapim Brass Polyax	2x14 mm (14G)		No	FRONT	
REAR HUB		DT SWISS 350 Hybrid Classic IS model from MY2024	Boost 148 mm	Thru axle 12mm	6-Bolt	32	Sram XD Shimano MS	Ratchet 24	REAR	Sapim Brass Polyax	2x14 mm (14G)	No	REAR	1056gr +/-5%			

\*\* For the maximum tyre pressure, refer to the owner's manual or the decal on the wheel itself.

[Click or tap on the hub or spoke model to access spare parts information](#)

MOUNTAIN CONTROL (MC)

MC32 TEAM (up to MY2024)

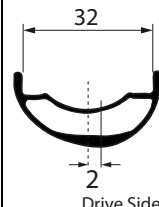
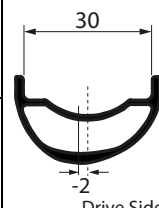
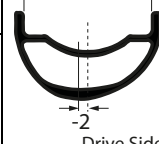
	MODEL	MATERIAL	SIZE	RIM TYPE	BRAKE TYPE	TUBELESS	INNER WIDTH	OFFSET	DIRECTIONAL SPOKE HOLES	SPOKE HOLES	ERD	ETRTO	JOINT	TUBELESS TAPE WIDTH	VALVE	COMPATIBLE TYRES	MAXIMUM PRESSURE	SECTION	
RIMS	29" FRONT RIM	MC30-F-29-28H	Aluminium AL6061	29"	Clincher Hookless	Disc	YES	32 mm	2 mm	YES	28	604 mm	622x32TSS	Sleeved	32 mm	44 mm	2.4"-2.8"	**	
	29" REAR RIM	MC30-R-29-32H	Aluminium AL6061	29"	Clincher Hookless	Disc	YES	30 mm	-2 mm	YES	32	600 mm	622x30TSS	Sleeved	30 mm	44 mm 57 mm on Wild with magnet in valve	2.05"-2.8"	**	
	27.5" REAR RIM	MC31-R-27-32H	Aluminium AL6061	27.5"	Clincher Hookless	Disc	YES	30 mm	-2 mm	YES	32	561.6 mm	584x30TSS	Sleeved	30 mm	44 mm 57 mm on Wild with magnet in valve	2.05"-2.8"	**	

	No. SPOKES	MODEL	DRIVE SIDE SPOKE PATTERN	NON-DRIVE SIDE SPOKE PATTERN	DRIVE SIDE SPOKE LENGTH	NON-DRIVE SIDE SPOKE LENGTH	DRIVE SIDE ASSEMBLY TENSION	DISC SIDE ASSEMBLY TENSION	LEADING SPOKE DRIVE SIDE	TRAILING SPOKE DRIVE SIDE	LEADING SPOKE NON-DRIVE SIDE	TRAILING SPOKE NON-DRIVE SIDE
SPOKES	29" FRONT	28	Sapim D-Sprint Butted. 14G (2 mm). J-Bend	3 Cross	3 Cross	299 mm	297 mm	—	1200 N	Outside	Inside	Outside Inside
	29" REAR	32	Sapim Race Butted. 14G (2 mm). J-Bend	3 Cross	3 Cross	291 mm	291 mm	1200 N	—	Inside	Outside	Outside Inside
	27.5" REAR	32	Sapim Race Butted. 14G (2 mm). J-Bend	3 Cross	3 Cross	271 mm	271 mm	1200 N	—	Inside	Outside	Outside Inside

	MODEL	SPACING (OLD)	AXLE	DISC TYPE	SPOKES	FREEHUB BODY	FREEHUB MECHANISM
HUB	29" FRONT	DT SWISS 350 Classic IS	Boost 110 mm	Thru axle 15mm	6-Bolt	28 J-Bend	—
	29" REAR	DT SWISS 350 Classic IS	Boost 148 mm	Thru axle 12 mm	6-Bolt	32 J-Bend	Sram XD or Shimano MS Ratchet 36
	27.5" REAR	DT SWISS 350 Classic IS	Boost 148 mm	Thru axle 12 mm	6-Bolt	32 J-Bend	Sram XD or Shimano MS Ratchet 36

	MODEL	MEASUREMENTS	SPOKE NIPPLE WASHERS	
NIPPLES	29" FRONT	Sapim Brass Polyax	2x14 mm (14G)	No
	29" REAR	Sapim Brass Polyax	2x14 mm (14G)	No
	27.5" REAR	Sapim Brass Polyax	2x14 mm (14G)	No

	WHEEL	WEIGHT
WEIGHT	29" FRONT	898gr +/-5%
	29" REAR	1046gr +/-5%
	27.5" REAR	1010gr +/-5%

**USE**

**ASTM Condition 5**  
(See user manual)

Maximum weight of the system  
(bicycle + cyclist + equipment)  
= **135 kg.**

\*\* For the maximum tyre pressure, refer to the owner's manual or the decal on the wheel itself.

[Click or tap on the hub or spoke model to access spare parts information](#)

MOUNTAIN CONTROL (MC)

MC32 TEAM (MY2025)

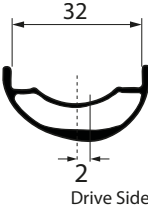
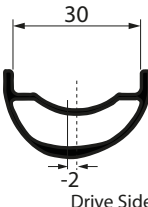
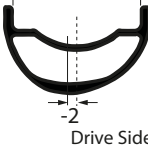
	MODEL	MATERIAL	SIZE	RIM TYPE	BRAKE TYPE	TUBELESS	INNER WIDTH	OFFSET	DIRECTIONAL SPOKE HOLES	SPOKE HOLES	ERD	ETRTO	JOINT	TUBELESS TAPE WIDTH	VALVE	COMPATIBLE TYRES	MAXIMUM PRESSURE	SECTION	
RIMS	29" FRONT RIM	MC36-F-29-28H	Aluminium AL6061	29"	Clincher Hookless	Disc	YES	32 mm	2 mm	YES	28	612.3 mm	622x32TSS	Sleeved	32 mm	44 mm	2.4"-2.8"	**	
	29" REAR RIM	MC36-R-29-32H	Aluminium AL6061	29"	Clincher Hookless	Disc	YES	30 mm	-2 mm	YES	32	610.9 mm	622x30TSS	Sleeved	30 mm	44 mm 57 mm on Wild with magnet in valve	2.05"-2.8"	**	
	27.5" REAR RIM	MC37-R-27-32H	Aluminium AL6061	27.5"	Clincher Hookless	Disc	YES	30 mm	-2 mm	YES	32	572.9 mm	584x30TSS	Sleeved	30 mm	44 mm 57 mm on Wild with magnet in valve	2.05"-2.8"	**	

	No. SPOKES	MODEL	DRIVE SIDE SPOKE PATTERN	NON-DRIVE SIDE SPOKE PATTERN	DRIVE SIDE SPOKE LENGTH	NON-DRIVE SIDE SPOKE LENGTH	DRIVE SIDE ASSEMBLY TENSION	DISC SIDE ASSEMBLY TENSION	LEADING SPOKE DRIVE SIDE	TRAILING SPOKE DRIVE SIDE	LEADING SPOKE NON-DRIVE SIDE	TRAILING SPOKE NON-DRIVE SIDE
SPOKES	29" FRONT	Sapim D-Light Butted, 14G (2 mm). J-Bend	3 Cross	3 Cross	302 mm	300 mm	—	1300 N	Outside	Inside	Outside	Inside
	29" REAR	Sapim Sprint Butted, 14G (2 mm). J-Bend	3 Cross	3 Cross	295 mm	295 mm	1300 N	—	Inside	Outside	Outside	Inside
	27.5" REAR	Sapim Sprint Butted, 14G (2 mm). J-Bend	3 Cross	3 Cross	276 mm	276 mm	1300 N	—	Inside	Outside	Outside	Inside

	MODEL	SPACING (OLD)	AXLE	DISC TYPE	SPOKES	FREEHUB BODY	FREEHUB MECHANISM
HUB	29" FRONT	DT SWISS 350 Classic IS	Boost 110 mm	Thru axle 15mm	6-Bolt	28 J-Bend	—
	29" REAR	DT SWISS 350 Classic IS	Boost 148 mm	Thru axle 12 mm	6-Bolt	32 J-Bend	Sram XD or Shimano MS Ratchet 36
	27.5" REAR	DT SWISS 350 Classic IS	Boost 148 mm	Thru axle 12 mm	6-Bolt	32 J-Bend	Sram XD or Shimano MS Ratchet 36

	MODEL	MEASUREMENTS	SPOKE NIPPLE WASHERS	
NIPPLES	29" FRONT	Sapim Alloy Double Square	2x18 mm (14G)	No
	29" REAR	Sapim Alloy Double Square	2x18 mm (14G)	No
	27.5" REAR	Sapim Alloy Double Square	2x18 mm (14G)	No

	WHEEL	WEIGHT
WEIGHT	29" FRONT	970g +/-5%
	29" REAR	1108g +/-5%
	27.5" REAR	1055g +/-5%

USE
<p><b>ASTM Condition 5</b> (See user manual)</p> <p>Maximum weight of the system (bicycle + cyclist + equipment) = <b>135 kg.</b></p>

\*\* For the maximum tyre pressure, refer to the owner's manual or the decal on the wheel itself.

[Click or tap on the hub or spoke model to access spare parts information](#)

MOUNTAIN CONTROL (MC)

MC32 TEAM (from MY2026)

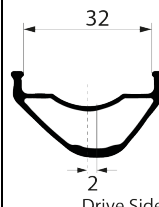
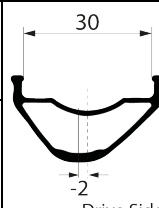
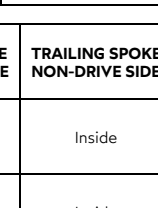
	MODEL	MATERIAL	SIZE	RIM TYPE	BRAKE TYPE	TUBELESS	INNER WIDTH	OFFSET	DIRECTIONAL SPOKE HOLES	SPOKE HOLES	ERD	ETRTO	JOINT	TUBELESS TAPE WIDTH	VALVE	COMPATIBLE TYRES	MAXIMUM PRESSURE	SECTION	
RIMS	29" FRONT RIM	MC36-F-29-28H	Aluminium AL6061	29"	Clincher Minihook	Disc	YES	32 mm	2 mm	YES	28	612.3 mm	622x32TSS	Sleeved	32 mm	44 mm	2.4"-2.8"	**	
	29" REAR RIM	MC36-R-29-32H	Aluminium AL6061	29"	Clincher Minihook	Disc	YES	30 mm	-2 mm	YES	32	610.9 mm	622x30TSS	Sleeved	30 mm	44 mm 57 mm on Wild with magnet in valve	2.05"-2.8"	**	
	27.5" REAR RIM	MC37-R-27-32H	Aluminium AL6061	27.5"	Clincher Minihook	Disc	YES	30 mm	-2 mm	YES	32	572.9 mm	584x30TSS	Sleeved	30 mm	44 mm 57 mm on Wild with magnet in valve	2.05"-2.8"	**	

	No. SPOKES	MODEL	DRIVE SIDE SPOKE PATTERN	NON-DRIVE SIDE SPOKE PATTERN	DRIVE SIDE SPOKE LENGTH	NON-DRIVE SIDE SPOKE LENGTH	DRIVE SIDE ASSEMBLY TENSION	DISC SIDE ASSEMBLY TENSION	LEADING SPOKE DRIVE SIDE	TRAILING SPOKE DRIVE SIDE	LEADING SPOKE NON-DRIVE SIDE	TRAILING SPOKE NON-DRIVE SIDE
SPOKES	29" FRONT	Sapim D-Light Butted, 14G (2 mm). J-Bend	3 Cross	3 Cross	298 mm	297 mm	—	1300 N	Outside	Inside	Outside	Inside
	29" REAR	Sapim Sprint Butted, 14G (2 mm). J-Bend	3 Cross	3 Cross	291 mm	291 mm	1300 N	—	Inside	Outside	Outside	Inside
	27.5" REAR	Sapim Sprint Butted, 14G (2 mm). J-Bend	3 Cross	3 Cross	272 mm	272 mm	1300 N	—	Inside	Outside	Outside	Inside

	MODEL	SPACING (OLD)	AXLE	DISC TYPE	SPOKES	FREEHUB BODY	FREEHUB MECHANISM
HUB	29" FRONT	OQUO LTD DT 350 INSIDE	Boost 110 mm	Thru axle 15mm	6-Bolt	28 J-Bend	—
	29" REAR	OQUO LTD DT 350 DEG INSIDE	Boost 148 mm	Thru axle 12 mm	6-Bolt	32 J-Bend	Sram XD or Shimano MS Ratchet DEG 72
	27.5" REAR	OQUO LTD DT 350 DEG INSIDE	Boost 148 mm	Thru axle 12 mm	6-Bolt	32 J-Bend	Sram XD or Shimano MS Ratchet DEG 72

	MODEL	MEASUREMENTS	SPOKE NIPPLE WASHERS	
NIPPLES	29" FRONT	Sapim Alloy Double Square	2x18 mm (14G)	No
	29" REAR	Sapim Alloy Double Square	2x18 mm (14G)	No
	27.5" REAR	Sapim Alloy Double Square	2x18 mm (14G)	No

	WHEEL	WEIGHT
WEIGHT	29" FRONT	950g +/-5%
	29" REAR	1125g +/-5%
	27.5" REAR	1075g +/-5%

USE
<p><b>ASTM Condition 5</b> (See user manual)</p> <p>Maximum weight of the system (bicycle + cyclist + equipment) = <b>135 kg.</b></p>

\*\* For the maximum tyre pressure, refer to the owner's manual or the decal on the wheel itself.

[Click or tap on the hub or spoke model to access spare parts information](#)

## MOUNTAIN CONTROL (MC)

## MC32 TEAM RALLON DH MY2026 (OEM)

## NOTICE

This MC32 TEAM wheelset is only available on Orbea Rallon DH MY2026 complete bike assemblies.

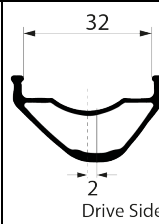
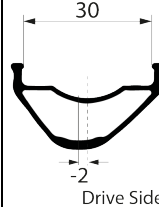
RIMS		MODEL	MATERIAL	SIZE	RIM TYPE	BRAKE TYPE	TUBELESS	INNER WIDTH	OFFSET	DIRECTIONAL SPOKE HOLES	SPOKE HOLES	ERD	ETRTO	JOINT	TUBELESS TAPE WIDTH	VALVE	COMPATIBLE TYRES	MAXIMUM PRESSURE	SECTION
	29" FRONT RIM	MC36-F-29-28H	Aluminium AL6061	29"	Clincher Minihook	Disc	YES	32 mm	2 mm	YES	28	612.3 mm	622x32TSS	Sleeved	32 mm	44 mm	2.4"-2.8"	**	
27.5" REAR RIM	MC37-R-27-32H	Aluminium AL6061	27.5"	Clincher Minihook	Disc	YES	30 mm	-2 mm	YES	32	572.9 mm	584x30TSS	Sleeved	30 mm	44 mm 57 mm on Wild with magnet in valve	2.05"-2.8"	**		

SPOKES		No. SPOKES	MODEL	DRIVE SIDE SPOKE PATTERN	NON-DRIVE SIDE SPOKE PATTERN	DRIVE SIDE SPOKE LENGTH	NON-DRIVE SIDE SPOKE LENGTH	DRIVE SIDE ASSEMBLY TENSION	DISC SIDE ASSEMBLY TENSION	LEADING SPOKE DRIVE SIDE	TRAILING SPOKE DRIVE SIDE	LEADING SPOKE NON-DRIVE SIDE	TRAILING SPOKE NON-DRIVE SIDE
	29" FRONT	28	Sapim Race Butted, 14G (2 mm). J-Bend	3 Cross	3 Cross	296 mm	296 mm	—	1300 N	Outside	Inside	Outside	Inside
27.5" REAR	32	Sapim Race Butted, 14G (2 mm). J-Bend	3 Cross	3 Cross	272 mm	272 mm	1300 N	—	Inside	Outside	Outside	Inside	

HUB		MODEL	SPACING (OLD)	AXLE	DISC TYPE	SPOKES	FREEHUB BODY	FREEHUB MECHANISM	NIPPLES		MODEL	MEASUREMENTS	SPOKE NIPPLE WASHERS	WEIGHT		WHEEL	WEIGHT	USE
	29" FRONT	DT SWISS 350 Classic IS	Boost 110 mm	Thru axle 20mm	6-Bolt	28 J-Bend	—	—		29" FRONT	Sapim Brass Polyax	2x14 mm (14G)	No		29" FRONT	970g +/-5%	ASTM Condition 5 (See user manual) Maximum weight of the system (bicycle + cyclist + equipment) = <b>135 kg.</b>	
27.5" REAR	DT SWISS 350 Classic IS	Boost 148 mm	Thru axle 12 mm	6-Bolt	32 J-Bend	Shimano HG	Ratchet 36 SL	27.5" REAR	Sapim Brass Polyax	2x14 mm (14G)	No	27.5" REAR	1055g +/-5%					

\*\* For the maximum tyre pressure, refer to the owner's manual or the decal on the wheel itself.

[Click or tap on the hub or spoke model to access spare parts information](#)

MOUNTAIN CONTROL (MC)

MC32 TEAM POWER (up to MY2023)

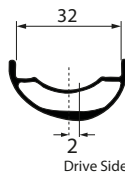
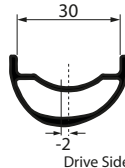
RIMS		MODEL	MATERIAL	SIZE	RIM TYPE	BRAKE TYPE	TUBELESS	INTERNAL WIDTH	OFFSET	DIRECTIONAL SPOKE HOLES	SPOKE HOLES	ERD	ETRT0	JOINT	TUBELESS TAPE WIDTH	VALVE	COMPATIBLE TYRES	MAXIMUM PRESSURE	SECTION
	FRONT RIM	MC31-F-29-32H	Aluminium AL6061	29"	Clincher Hookless	Disc	YES	32 mm	2 mm	YES	32	604 mm	622x32TSS	Sleeved	32 mm	44 mm	2.4"-2.8"	**	
REAR RIM	MC30-R-29-32H	Aluminium AL6061	29"	Clincher Hookless	Disc	YES	30 mm	-2 mm	YES	32	600 mm	622x30TSS	Sleeved	30 mm	44 mm 57 mm on Wild with magnet in valve	2.05"-2.8"	**		

SPOKES		No. SPOKES	MODEL	DRIVE SIDE SPOKE PATTERN	NON-DRIVE SIDE SPOKE PATTERN	DRIVE SIDE SPOKE LENGTH	NON-DRIVE SIDE SPOKE LENGTH	DRIVE SIDE ASSEMBLY TENSION	DISC SIDE ASSEMBLY TENSION	LEADING SPOKE DRIVE SIDE	TRAILING SPOKE DRIVE SIDE	LEADING SPOKE NON-DRIVE SIDE	TRAILING SPOKE NON-DRIVE SIDE
	FRONT		32	Sapim E-Light. Butted 14G (2 mm) J-Bend	3 Cross	3 Cross	294 mm	292 mm	—	1200 N	Outside	Inside	Outside
REAR		32	Sapim E-Light. Butted 14G (2 mm) J-Bend	3 Cross	3 Cross	291 mm	293 mm	1200 N	—	Inside	Outside	Outside	Inside

HUB		MODEL	SPACING (OLD)	AXLE	DISC TYPE	SPOKES	FREEHUB BODY	FREEHUB MECHANISM
	FRONT HUB		DT SWISS 350 Hybrid Classic IS model up to MY2023	Boost 110 mm	Thru axle 15mm	6-Bolt	32	—
REAR HUB		DT SWISS 350 Hybrid Classic IS model up to MY2023	Boost 148 mm	Thru axle 12mm	6-Bolt	32	Sram XD Shimano MS	Ratchet 24

NIPPLES		MODEL	MEASUREMENTS	SPOKE NIPPLE WASHERS
	FRONT		Sapim Brass Polyax	2x14 mm (14G)
REAR		Sapim Brass Polyax	2x14 mm (14G)	No

WEIGHT		WHEEL	WEIGHT
	FRONT		FRONT
REAR		REAR	1060gr +/-5%

**USE**

**ASTM Condition 5**  
(See user manual)



Maximum weight of the system  
(bicycle + cyclist + equipment)  
= **135 kg.**

\*\* For the maximum tyre pressure, refer to the owner's manual or the decal on the wheel itself.

[Click or tap on the hub or spoke model to access spare parts information](#)

MOUNTAIN CONTROL (MC)

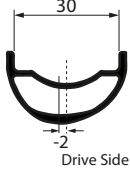
MC32 TEAM POWER (MY2024)

	MODEL	MATERIAL	SIZE	RIM TYPE	BRAKE TYPE	TUBELESS	INNER WIDTH	OFFSET	DIRECTIONAL SPOKE HOLES	SPOKE HOLES	ERD	ETRTO	JOINT	TUBELESS TAPE WIDTH	VALVE	COMPATIBLE TYRES	MAXIMUM PRESSURE	SECTION	
RIMS	29" FRONT RIM	MC30-F-29-28H	Aluminium AL6061	29"	Clincher Hookless	Disc	YES	32 mm	2 mm	YES	28	604 mm	622x32TSS	Sleeved	32 mm	44 mm	2.4"-2.8"	**	
	29" REAR RIM	MC30-R-29-32H	Aluminium AL6061	29"	Clincher Hookless	Disc	YES	30 mm	-2 mm	YES	32	600 mm	622x30TSS	Sleeved	30 mm	44 mm 57 mm on Wild with magnet in valve	2.05"-2.8"	**	
	27.5" REAR RIM	MC31-R-27-32H	Aluminium AL6061	27.5"	Clincher Hookless	Disc	YES	30 mm	-2 mm	YES	32	561.6 mm	584x30TSS	Sleeved	30 mm	44 mm 57 mm on Wild with magnet in valve	2.05"-2.8"	**	

	No. SPOKES	MODEL	DRIVE SIDE SPOKE PATTERN	NON-DRIVE SIDE SPOKE PATTERN	DRIVE SIDE SPOKE LENGTH	NON-DRIVE SIDE SPOKE LENGTH	DRIVE SIDE ASSEMBLY TENSION	DISC SIDE ASSEMBLY TENSION	LEADING SPOKE DRIVE SIDE	TRAILING SPOKE DRIVE SIDE	LEADING SPOKE NON-DRIVE SIDE	TRAILING SPOKE NON-DRIVE SIDE	
SPOKES	29" FRONT	28	Sapim E-Light, Butted 14G (2 mm) J-Bend	3 Cross	3 Cross	298 mm	297 mm	—	1200 N	Outside	Inside	Outside	Inside
	29" REAR	32	Sapim E-Light, Butted 14G (2 mm) J-Bend	3 Cross	3 Cross	291 mm	292 mm	1200 N	—	Inside	Outside	Outside	Inside
	27.5" REAR	32	Sapim E-Light, Butted 14G (2 mm) J-Bend	3 Cross	3 Cross	271 mm	271 mm	1200 N	—	Inside	Outside	Outside	Inside

	MODEL	SPACING (OLD)	AXLE	DISC TYPE	SPOKES	FREEHUB BODY	FREEHUB MECHANISM
HUB	29" FRONT	DT SWISS 350 Hybrid Classic IS model from MY2024	Boost 110 mm	Thru axle 15mm	6-Bolt	28 J-Bend	—
	29" REAR	DT SWISS 350 Hybrid Classic IS model from MY2024	Boost 148 mm	Thru axle 12 mm	6-Bolt	32 J-Bend	Sram XD or Shimano MS
	27.5" REAR	DT SWISS 350 Hybrid Classic IS model from MY2024	Boost 148 mm	Thru axle 12 mm	6-Bolt	32 J-Bend	Sram XD or Shimano MS

	MODEL	MEASUREMENTS	SPOKE NIPPLE WASHERS	
NIPPLES	29" FRONT	Sapim Brass Polyax	2x14 mm (14G)	No
	29" REAR	Sapim Brass Polyax	2x14 mm (14G)	No
	27.5" REAR	Sapim Brass Polyax	2x14 mm (14G)	No

	WHEEL	WEIGHT
WEIGHT	29" FRONT	985gr +/-5%
	29" REAR	1160gr +/-5%
	27.5" REAR	1085gr +/-5%

**USE**

**ASTM Condition 5**  
(See user manual)



Maximum weight of the system  
(bicycle + cyclist + equipment)  
= **135 kg.**

\*\* For the maximum tyre pressure, refer to the owner's manual or the decal on the wheel itself.

[Click or tap on the hub or spoke model to access spare parts information](#)

MOUNTAIN CONTROL (MC)

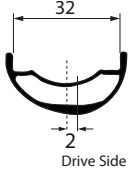
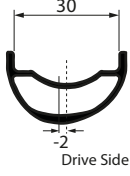
MC32 TEAM POWER (MY2025)

	MODEL	MATERIAL	SIZE	RIM TYPE	BRAKE TYPE	TUBELESS	INNER WIDTH	OFFSET	DIRECTIONAL SPOKE HOLES	SPOKE HOLES	ERD	ETRTO	JOINT	TUBELESS TAPE WIDTH	VALVE	COMPATIBLE TYRES	MAXIMUM PRESSURE	SECTION	
RIMS	29" FRONT RIM	MC36-F-29-28H	Aluminium AL6061	29"	Clincher Hookless	Disc	YES	32 mm	2 mm	YES	28	612.3 mm	622x32TSS	Sleeved	32 mm	44 mm	2.4"-2.8"	**	
	29" REAR RIM	MC36-R-29-32H	Aluminium AL6061	29"	Clincher Hookless	Disc	YES	30 mm	-2 mm	YES	32	610.9 mm	622x30TSS	Sleeved	30 mm	44 mm 57 mm on Wild with magnet in valve	2.05"-2.8"	**	
	27.5" REAR RIM	MC37-R-27-32H	Aluminium AL6061	27.5"	Clincher Hookless	Disc	YES	30 mm	-2 mm	YES	32	572.9 mm	584x30TSS	Sleeved	30 mm	44 mm 57 mm on Wild with magnet in valve	2.05"-2.8"	**	

	No. SPOKES	MODEL	DRIVE SIDE SPOKE PATTERN	NON-DRIVE SIDE SPOKE PATTERN	DRIVE SIDE SPOKE LENGTH	NON-DRIVE SIDE SPOKE LENGTH	DRIVE SIDE ASSEMBLY TENSION	DISC SIDE ASSEMBLY TENSION	LEADING SPOKE DRIVE SIDE	TRAILING SPOKE DRIVE SIDE	LEADING SPOKE NON-DRIVE SIDE	TRAILING SPOKE NON-DRIVE SIDE	
SPOKES	29" FRONT	28	Sapim E-Light, Butted 14G (2 mm) J-Bend	3 Cross	3 Cross	301 mm	300 mm	—	1300 N	Outside	Inside	Outside	Inside
	29" REAR	32	Sapim E-Light, Butted 14G (2 mm) J-Bend	3 Cross	3 Cross	294 mm	295 mm	1300 N	—	Inside	Outside	Outside	Inside
	27.5" REAR	32	Sapim E-Light, Butted 14G (2 mm) J-Bend	3 Cross	3 Cross	275 mm	276 mm	1300 N	—	Inside	Outside	Outside	Inside

HUB	MODEL	SPACING (OLD)	AXLE	DISC TYPE	SPOKES	FREEHUB BODY	FREEHUB MECHANISM	NIPPLES	MODEL	MEASUREMENTS	SPOKE NIPPLE WASHERS	WEIGHT	WHEEL	WEIGHT	USE		
	29" FRONT	DT SWISS 350 Hybrid Classic IS model from MY2024	Boost 110 mm	Thru axle 15mm	6-Bolt	28 J-Bend	—		—	29" FRONT	Sapim Alloy Double Square		2x18 mm (14G)	No		29" FRONT	1030g +/-5%
	29" REAR	DT SWISS 350 Hybrid Classic IS model from MY2024	Boost 148 mm	Thru axle 12 mm	6-Bolt	32 J-Bend	Sram XD or Shimano MS		10 ° Ratchet 32	29" REAR	Sapim Alloy Double Square		2x18 mm (14G)	No		29" REAR	1180g +/-5%
27.5" REAR	DT SWISS 350 Hybrid Classic IS model from MY2024	Boost 148 mm	Thru axle 12 mm	6-Bolt	32 J-Bend	Sram XD or Shimano MS	10 ° Ratchet 32	27.5" REAR	Sapim Alloy Double Square	2x18 mm (14G)	No	27.5" REAR	1130g +/-5%				

**ASTM Condition 5**  
(See user manual)  
Maximum weight of the system  
(bicycle + cyclist + equipment)  
= **135 kg.**

\*\* For the maximum tyre pressure, refer to the owner's manual or the decal on the wheel itself.

[Click or tap on the hub or spoke model to access spare parts information](#)

MOUNTAIN CONTROL (MC)

MC32 TEAM POWER (from MY2026)

	MODEL	MATERIAL	SIZE	RIM TYPE	BRAKE TYPE	TUBELESS	INNER WIDTH	OFFSET	DIRECTIONAL SPOKE HOLES	SPOKE HOLES	ERD	ETRTO	JOINT	TUBELESS TAPE WIDTH	VALVE	COMPATIBLE TYRES	MAXIMUM PRESSURE	SECTION	
RIMS	29" FRONT RIM	MC36-F-29-28H	Aluminium AL6061	29"	Clincher Minihook	Disc	YES	32 mm	2 mm	YES	28	612.3 mm	622x32TSS	Sleeved	32 mm	44 mm	2.4"-2.8"	**	
	29" REAR RIM	MC36-R-29-32H	Aluminium AL6061	29"	Clincher Minihook	Disc	YES	30 mm	-2 mm	YES	32	610.9 mm	622x30TSS	Sleeved	30 mm	44 mm 57 mm on Wild with magnet in valve	2.05"-2.8"	**	
	27.5" REAR RIM	MC37-R-27-32H	Aluminium AL6061	27.5"	Clincher Minihook	Disc	YES	30 mm	-2 mm	YES	32	572.9 mm	584x30TSS	Sleeved	30 mm	44 mm 57 mm on Wild with magnet in valve	2.05"-2.8"	**	

	No. SPOKES	MODEL	DRIVE SIDE SPOKE PATTERN	NON-DRIVE SIDE SPOKE PATTERN	DRIVE SIDE SPOKE LENGTH	NON-DRIVE SIDE SPOKE LENGTH	DRIVE SIDE ASSEMBLY TENSION	DISC SIDE ASSEMBLY TENSION	LEADING SPOKE DRIVE SIDE	TRAILING SPOKE DRIVE SIDE	LEADING SPOKE NON-DRIVE SIDE	TRAILING SPOKE NON-DRIVE SIDE	
SPOKES	29" FRONT	28	Sapim E-Light, Butted 14G (2 mm) J-Bend	3 Cross	3 Cross	301 mm	300 mm	—	1300 N	Outside	Inside	Outside	Inside
	29" REAR	32	Sapim E-Light, Butted 14G (2 mm) J-Bend	3 Cross	3 Cross	294 mm	295 mm	1300 N	—	Inside	Outside	Outside	Inside
	27.5" REAR	32	Sapim E-Light, Butted 14G (2 mm) J-Bend	3 Cross	3 Cross	275 mm	276 mm	1300 N	—	Inside	Outside	Outside	Inside

	MODEL	SPACING (OLD)	AXLE	DISC TYPE	SPOKES	FREEHUB BODY	FREEHUB MECHANISM
HUB	29" FRONT	DT SWISS 350 Hybrid Classic IS model from MY2024	Boost 110 mm	Thru axle 15mm	6-Bolt	28 J-Bend	—
	29" REAR	DT SWISS 350 Hybrid Classic IS model from MY2024	Boost 148 mm	Thru axle 12 mm	6-Bolt	32 J-Bend	Sram XD or Shimano MS
	27.5" REAR	DT SWISS 350 Hybrid Classic IS model from MY2024	Boost 148 mm	Thru axle 12 mm	6-Bolt	32 J-Bend	Sram XD or Shimano MS

	MODEL	MEASUREMENTS	SPOKE NIPPLE WASHERS	
NIPPLES	29" FRONT	Sapim Alloy Double Square	2x18 mm (14G)	No
	29" REAR	Sapim Alloy Double Square	2x18 mm (14G)	No
	27.5" REAR	Sapim Alloy Double Square	2x18 mm (14G)	No

	WHEEL	WEIGHT
WEIGHT	29" FRONT	1030g +/-5%
	29" REAR	1180g +/-5%
	27.5" REAR	1130g +/-5%

**USE**

**ASTM Condition 5**  
(See user manual)

Maximum weight of the system  
(bicycle + cyclist + equipment)  
= **135 kg.**

\*\* For the maximum tyre pressure, refer to the owner's manual or the decal on the wheel itself.

[Click or tap on the hub or spoke model to access spare parts information](#)

---

## MAINTENANCE OF OQUO WHEELS

The information contained in this manual is primarily intended for OQUO distributors and users with some experience in wheel maintenance.

If, as a user, you do not have the knowledge to carry out the maintenance procedures described in this technical manual or install the spare parts listed, please take your wheels to an OQUO dealer for repair or maintenance.

You can find the contact information of our distributors on our website:

[www.oquowheels.com](http://www.oquowheels.com)

### NOTICE

Damage caused by improper maintenance or repair work is not covered by the warranty conditions.



Incorrect repairs, maintenance, or installation of components may affect the integrity and function of the wheels and could lead to accidents and serious injury or death.

### TOOLS

Always use the right tools and products for a specific maintenance or repair operation. Unsuitable or poorly maintained tools, or the use of generic products, may cause damage to components that are not then covered by the warranty conditions.

Refer to the table of maintenance periods in this manual to see the checks and maintenance periods for the wheels and their components.

See the hub maintenance section of this manual for hub manufacturers' maintenance manuals.

### TABLE OF MAINTENANCE SCHEDULE

Refer to the following table for checks and maintenance periods for the wheels and their components.

### NOTICE

The component maintenance periods indicated below are for reference, and depend largely on factors such as the weather conditions (adverse conditions considerably reduce the life of the components and maintenance times), cleanliness of the bicycle and its components (components with accumulated dirt wear out more quickly) and use (more demanding use of the bicycle will require shorter maintenance periods).

Damage to components resulting from non-observance of maintenance periods is not covered by the warranty conditions.

The tools to be used are specified in this manual, or reference is made to the maintenance manuals of the manufacturers of components used on our wheels, where the appropriate tools are detailed.

CHECK	FREQUENCY		
	Before every use	Every 2-3 uses	Every 4-6 months (40-60 hours)*/**
Clean the wheels with soapy water or specific bicycle cleaning products. (do not use ammonia or solvent based products)		✓	✓
Inspection of tightness and condition of thru axles or quick-release skewers	✓		
Inspection of the condition of the brake rotors	✓		
Checking the tightness of the brake rotors			✓
Inspection of rim truing	✓		✓
Tire condition inspection (cuts and wear)	✓		
Manual inspection of tension and condition of spokes	✓		
Manual inspection of rotation and play of hubs and freehub bodies	✓		
Inspection of tire pressure and air leaks	✓		
Inspection of damage to rim, hubs and spokes	✓		✓
Inspection and/or refilling of sealant in tubeless tires			✓
Cleaning of liquid sealant in rim, tire and valve			✓
Replacement of the rim tape (standard or tubeless) if necessary			✓
Spoke tension inspection with tension meter			✓
Inspection of the hub operation, bearing and body service according to manufacturer's instructions if necessary			✓
Tube replacement on standard tires			✓

\*These times may be shorter depending on the riding style and conditions of use.

\*\*Heavier users or those who use the wheels near their system weight limits may need to shorten maintenance periods.

## TOOLS FOR THE MAINTENANCE AND CONSTRUCTION OF WHEELS

Listed here are the tools necessary for the correct maintenance of OQUO wheels with regard to construction and truing. Please refer to the manufacturer's documentation for the tools required for hub maintenance.

This list is subject to changes in wheel specifications which may need the use of other tools not shown here. If in doubt, consult OQUO.

### 1. DOUBLE-SIDED WHEEL TRUING STAND

Always use a quality double-sided wheel truing stand to check the truing and run-out of the wheels. Do not perform these wheel checks and wheel maintenance with the wheel mounted on the bicycle. The results may not be accurate.

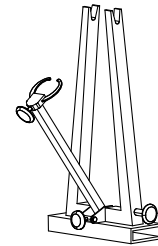

### 2. SPOKE WRENCH

**External:** For adjusting the nipples from the outside of the rim. For most spoke nipples.

**Internal:** For adjusting the nipples from the inside of the rim (rim bed). Sapim Double Square nipples can be adjusted from the inside of the rim as well as from the outside with an external spoke wrench.

#### NOTICE

Whether an internal or external spoke wrench is used, it must be the correct size for the nipples to avoid damaging and/or rounding the nipples. It is useful to have spoke wrenches of various sizes available and to test them on the nipples to be adjusted to ensure that the correct size of spoke wrench is used.

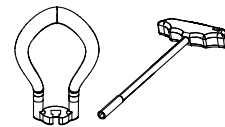

### 3. FLAT SPOKE WRENCH

Use a tool to hold flat spokes when tightening the nipple to avoid twisting the spoke.

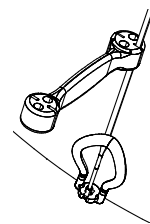

#### 4. TENSION METER

Always use a quality tension meter and regularly check its calibration according to the manufacturer's instructions.

Follow the manufacturer's instructions for proper use and to properly interpret the tension reading depending on the specifications of the spokes.

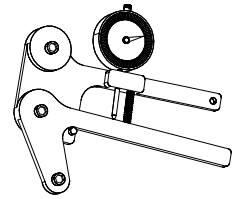

---

#### 5. ALIGNMENT GAUGE

Always use a dishing gauge to check the alignment of the rim in relation to the hub ends that contact the inside of the frame or fork.

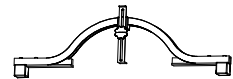

### CHECKING THE SPOKE TENSION

Regularly check the tension and state of the spokes.

Regularly check the lateral (1) and radial (2) runout and dishing (3) of your wheels on a wheel truing stand. Wheel checks and adjustments while the wheel is mounted on the bicycle may not be accurate.

If any spokes need to be adjusted, use a spoke wrench of the correct size to adjust the tension of these spokes.

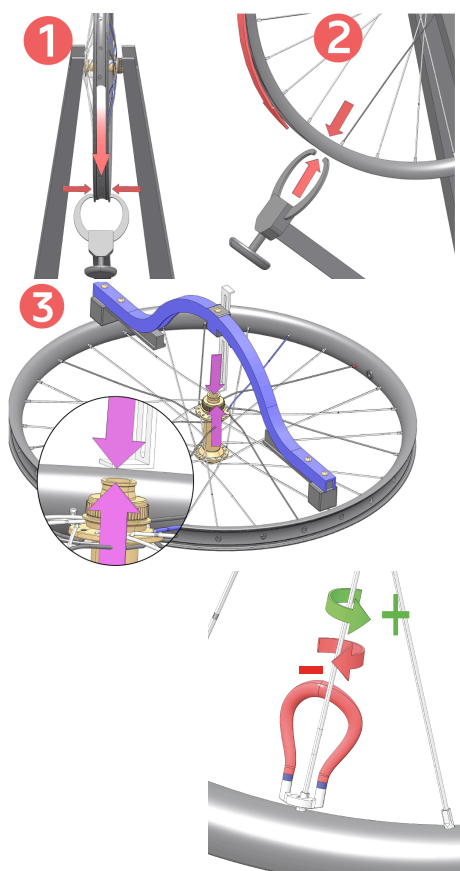

Use a flat spoke wrench to hold the spokes flat to prevent twisting of the spoke. You can also clamp round spokes with smooth pliers to prevent twisting. Avoid damaging the spokes.

When adjusting one or several spokes, check again the wheel's lateral and radial run-out and dishing. If you adjust the tension of 4 or more spokes, destress the wheel and check its truing.

See how to destress the wheel in the wheel construction section of this manual. Check the runout and tension targets for OQUO wheels in the Wheel Construction section of this manual.

### REPLACING A SPOKE

Broken, bent or damaged spokes must be replaced immediately.

To replace a spoke, remove the tyre and rim tape from the wheel.

It may be necessary to remove the brake disc, and on rear wheels the cassette, to replace a spoke.



Use a spoke wrench to remove the nipple (1, 2)

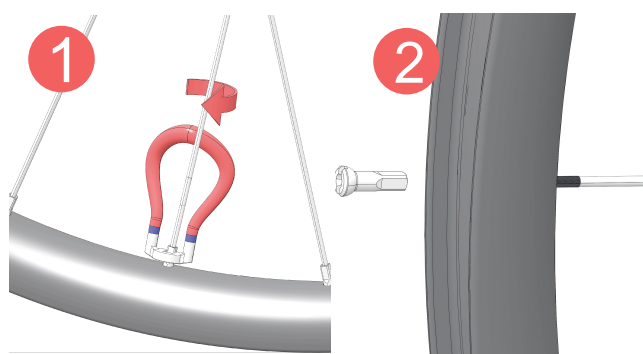

Remove the spoke from the hub (3). If the spoke is broken, you can remove the broken spoke together with the nipple and disassemble the hub segment separately (4).

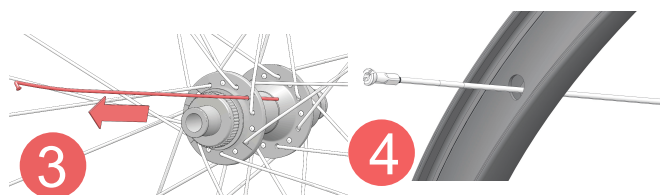

Install the new spoke from the hub side and in the position of the original spoke.

Refer to the Spoke Patterns section of the Wheel Construction chapter of this manual for a guide to the position of the spokes in the different spoke patterns. Please refer to the technical specification table in this manual for the spoke model and length of your OQUO wheels.

Use a wheel truing stand and the appropriate tools to tension the new spoke. After installation, check that the spoke tension is correct and that the lateral and radial runout and the wheel dishing are correct.

It may be necessary to adjust several spokes in addition to the replaced spoke. If fitting multiple spokes, distress the wheel as explained in the Wheel Construction section of this manual and check that alignment, and tension and runout tolerances are correct.

Reinstall the rim tape, tyre and brake disc and cassette if it was necessary to remove them.

---

## HUB MAINTENANCE

### HUB MAINTENANCE

Refer to the OQUO wheel technical specifications table in this manual to find out which hub model your wheel model uses.

The information contained in this manual and the other manufacturers' manuals referenced herein is primarily intended for OQUO or component manufacturer's distributors and for users with some experience in wheel maintenance.

If, as a user, you do not have the knowledge to carry out the maintenance procedures described in this technical manual or install the spare parts listed, please take your wheels to an OQUO dealer for repair or maintenance.

You can find the contact information for our distributors on our website [www.oquowheels.com](http://www.oquowheels.com)

#### NOTICE

---

Damage caused by improper maintenance or repair work is not covered by the warranty conditions.



---

Incorrect repairs, maintenance, or installation of components may affect the integrity and function of the wheels and could lead to accidents and serious injury or death.

### DT SWISS MTB & OQUO DT INSIDE HUBS

See the following page for links to the DT Swiss MTB hub manuals on the manufacturer's website:

#### NOTICE

---

Oquo DT Inside hubs are made up of the same components as the equivalent DT Swiss hub (except the hub body), so service and maintenance procedures are the same as for the equivalent DT Swiss hub.

HUB MODEL	MANUAL TYPE/ NAME	CONTENTS	LINK TO DOCUMENT
All Oquo DT Inside and DT Swiss hubs	User manual/ HUBS USER MANUAL ALL HUBS	<ul style="list-style-type: none"> <li>• General information</li> <li>• Warnings for use</li> <li>• Assembly</li> <li>• Maintenance and care</li> </ul>	<a href="https://www.dtswiss.com/pmt/00/00/00/00/00/00/00/00/00/00/00/00/00/00/86/2/MAN_HXWXXXXXX1610S_WEB_ZZ_001.pdf">https://www.dtswiss.com/pmt/00/00/00/00/00/00/00/00/00/00/00/00/00/00/86/2/MAN_HXWXXXXXX1610S_WEB_ZZ_001.pdf</a>
Oquo DT Inside and DT Swiss front hubs	Technical manual/ FRONT HUBS TECHNICAL MANUAL	<ul style="list-style-type: none"> <li>• Dismantling, cleaning and replacement of the bearings and the axle</li> <li>• Tools, components and materials required</li> </ul>	<a href="https://d2a13k6araex7u.cloudfront.net/pmt/00/00/00/00/00/00/00/00/10/00/00/05/56/2/MAN_HXD10000005562S_WEB_EN_001.pdf">https://d2a13k6araex7u.cloudfront.net/pmt/00/00/00/00/00/00/00/00/10/00/00/05/56/2/MAN_HXD10000005562S_WEB_EN_001.pdf</a>
Oquo LTD DT Inside and DT Swiss 240 rear hub	Technical manual/ HUBS TECHNICAL MANUAL RATCHET EXP	<ul style="list-style-type: none"> <li>• Dismantling, cleaning and replacement of all parts of the hub</li> <li>• Tools, components and materials required</li> </ul>	<a href="https://www.dtswiss.com/pmt/00/00/00/00/00/00/00/00/10/00/00/03/11/1/MAN_HXD10000003111S_WEB_EN_001.pdf">https://www.dtswiss.com/pmt/00/00/00/00/00/00/00/00/10/00/00/03/11/1/MAN_HXD10000003111S_WEB_EN_001.pdf</a>
	Body maintenance manual RATCHET EXP FREEWHEEL MAINTENANCE	<ul style="list-style-type: none"> <li>• Dismantling, cleaning and replacement of the Ratchet EXP system and the body</li> <li>• Tools, components and materials required</li> </ul>	<a href="https://www.dtswiss.com/pmt/00/00/00/00/00/00/00/00/10/00/00/04/19/3/MAN_HXD10000004193S_XXX_EN_001.pdf">https://www.dtswiss.com/pmt/00/00/00/00/00/00/00/00/10/00/00/04/19/3/MAN_HXD10000004193S_XXX_EN_001.pdf</a>
	Ratchet EXP 36T to EXP 54T Replacement Manual RATCHET EXP HUBS 36 TO 54 CONVERSION	<ul style="list-style-type: none"> <li>• Replacing the Ratchet EXP 36T system with the EXP 54T</li> <li>• Tools, components and materials required</li> </ul>	<a href="https://www.dtswiss.com/pmt/00/00/00/00/00/00/00/00/10/00/00/03/77/3/MAN_HXD10000003773S_WEB_EN_001.pdf">https://www.dtswiss.com/pmt/00/00/00/00/00/00/00/00/10/00/00/03/77/3/MAN_HXD10000003773S_WEB_EN_001.pdf</a>
Oquo LTD DT Inside and DT Swiss 350 DEG 72 rear hub	All about the 350 DEG hub/ DT Swiss Support Page	<ul style="list-style-type: none"> <li>• Spare parts</li> <li>• Manuals</li> <li>• Videos</li> </ul>	<a href="https://www.dtswiss.com/en/support/product-support?matnr=H350TDDRR32SA5051S">https://www.dtswiss.com/en/support/product-support?matnr=H350TDDRR32SA5051S</a>
	Technical manual/ RATCHET DEG HUBS	<ul style="list-style-type: none"> <li>• Dismantling, cleaning and replacement of all parts of the hub</li> <li>• Tools, components and materials required</li> </ul>	<a href="https://d2a13k6araex7u.cloudfront.net/pmt/00/00/00/00/00/00/00/00/10/00/00/05/10/4/MAN_HXD10000005104S_WEB_EN_001.pdf">https://d2a13k6araex7u.cloudfront.net/pmt/00/00/00/00/00/00/00/00/10/00/00/05/10/4/MAN_HXD10000005104S_WEB_EN_001.pdf</a>
	Video/ 350 DEG COMPLETE SERVICE	<ul style="list-style-type: none"> <li>• Dismantling, cleaning and replacement of all parts of the hub</li> <li>• Tools, components and materials required</li> </ul>	<a href="https://www.youtube.com/watch?v=UMLquGPw2Jg">https://www.youtube.com/watch?v=UMLquGPw2Jg</a>
Oquo Team DT Inside and DT Swiss 350 rear hub	Technical manual HUBS TECHNICAL MANUAL RATCHET	<ul style="list-style-type: none"> <li>• Dismantling, cleaning and replacement of all parts of the hub</li> <li>• Tools, components and materials required</li> </ul>	<a href="https://www.dtswiss.com/pmt/00/00/00/00/00/00/00/00/10/00/00/00/89/6/MAN_WXD10000000896S_WEB_EN_001.pdf">https://www.dtswiss.com/pmt/00/00/00/00/00/00/00/00/10/00/00/00/89/6/MAN_WXD10000000896S_WEB_EN_001.pdf</a>
DT Swiss 350 Hybrid rear hub	Technical manual HUBS TECHNICAL MANUAL RATCHET	<ul style="list-style-type: none"> <li>• Dismantling, cleaning and replacement of all parts of the hub</li> <li>• Tools, components and materials required</li> </ul>	<a href="https://www.dtswiss.com/pmt/00/00/00/00/00/00/00/00/10/00/00/00/89/6/MAN_WXD10000000896S_WEB_EN_001.pdf">https://www.dtswiss.com/pmt/00/00/00/00/00/00/00/00/10/00/00/00/89/6/MAN_WXD10000000896S_WEB_EN_001.pdf</a>
DT Swiss 370 rear hub	Technical manual HUBS TECHNICAL MANUAL RATCHET LN	<ul style="list-style-type: none"> <li>• Dismantling, cleaning and replacement of all parts of the hub</li> <li>• Tools, components and materials required</li> </ul>	<a href="https://www.dtswiss.com/pmt/00/00/00/00/00/00/00/00/10/00/00/03/77/4/MAN_HXD10000003774S_WEB_EN_001.pdf">https://www.dtswiss.com/pmt/00/00/00/00/00/00/00/00/10/00/00/03/77/4/MAN_HXD10000003774S_WEB_EN_001.pdf</a>

## SPARE PARTS

### OQUO DT SWISS INSIDE HUBS SPARE PARTS

See the OQUO wheel technical specifications table for your wheels' hub model

#### OQUO DT SWISS INSIDE FRONT HUBS

##### Oquo LTD DT Swiss 240 Inside Straight Pull 15x110 24H Centerlock

See the OQUO wheel technical specifications table for your wheels' hub model

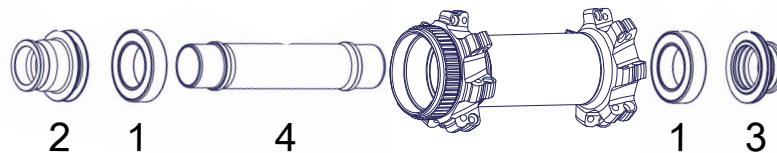

	DESCRIPTION	NUMBER PER HUB	ITEM No. DT DT SWISS	ITEM No. ORBEA
1	B.BEARING 1728 ESB/ESNB L	2	HSBXXX00N9115S	<a href="#">XB68</a>
2	FW ADAPT WP XXX/15 L BM DISC	1	HWAXXX00S2760S	<a href="#">XB69</a>
3	FW ADAPT WP XXX/15 R BM DISC	1	HWAXXX00S2761S	<a href="#">XB70</a>
4	FW AXLE AL 110 mm diam 17/64.3 mm	1	HRCXXX00N3296S	<a href="#">XB71</a>

	DESCRIPTION	ITEM No. DT DT SWISS	ITEM No. ORBEA
<b>Assembly compound</b>	DT Swiss universal grease 20 g	HXTXXX00NMG20S	<a href="#">XB72</a>
<b>Tools</b>	Installation cylinder diam 17 / 28mm x 40mm	HXTXXX00N9345S	<a href="#">XB73</a>
	Axle tool diam 17 mm	HXTXXX00N5067S	<a href="#">XB74</a>

Click on the part number to buy online. Hub spare parts are available exclusively to Orbea dealers through Kide (B2B access)

## OQUO DT SWISS INSIDE FRONT HUBS

### Oquo TEAM DT Swiss 350 Inside Straight Pull 15x110 28H Centerlock/6-bolt

See the OQUO wheel technical specifications table for your wheels' hub model

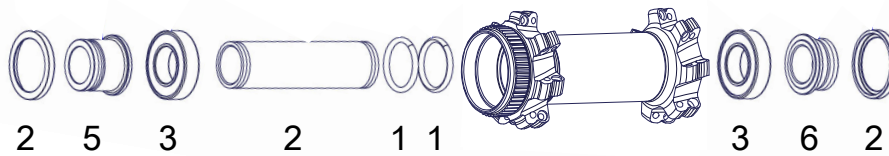

	DESCRIPTION	NUMBER PER HUB	ITEM No. DT SWISS	ITEM No. ORBEA
1	O-RING diam 18X2.5mm NBR 70 SHORE ISO3601	2	HSOXXX00X2164S	XC04
2	FW COVER FOR TA15 mm	2	HCD00100S4603S	XC05
3	B.BEARING 6902 ESB/ESNB L	2	HSBXXX00N2336S	XC06
4	SPACER diam 15mm x 67.2mm	1	HXD00000N6567C	XC07
5	FW ADAPT SP XXX/15 L B	1	HCA00100S7745S	XC08
6	FW ADAPT SP XXX/15 R B	1	HCA00100S7744S	XC09

	DESCRIPTION	ITEM No. DT SWISS	ITEM No. ORBEA
<b>Assembly compound</b>	DT Swiss universal grease 20 g	HXTXXX00NMG20S	XB72
<b>Tools</b>	Toolset 350 15mm	HWTXXX00N5290S	XC10
	Mounting tool	HXTXXX00N9793S	XC11

Click on the part number to buy online. Hub spare parts are available exclusively to Orbea dealers through Kide (B2B access)

## OQUO DT SWISS INSIDE FRONT HUBS

### Oquo LTD DT Swiss 350 Inside J-bend 15x110 28H 6-bolt

See the OQUO wheel technical specifications table for your wheels' hub model

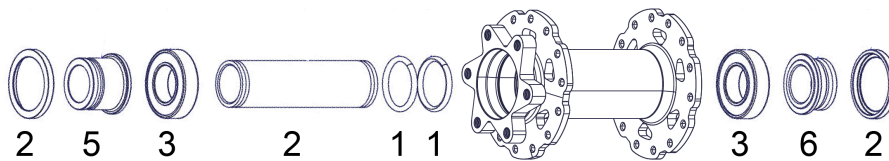

	DESCRIPTION	NUMBER PER HUB	ITEM No. DT SWISS	ITEM No. ORBEA
1	O-RING diam 18X2.5mm NBR 70 SHORE ISO3601	2	HSOXXX00X2164S	XC04
2	FW COVER FOR TA15 mm	2	HCD00100S4603S	XC05
3	B.BEARING 6902 ESB/ESNB L	2	HSBXXX00N2336S	XC06
4	SPACER diam 15mm x 67.2mm	1	HXD00000N6567C	XC07
5	FW ADAPT SP XXX/15 L B	1	HCA00100S7745S	XC08
6	FW ADAPT SP XXX/15 R B	1	HCA00100S7744S	XC09

	DESCRIPTION	ITEM No. DT SWISS	ITEM No. ORBEA
<b>Assembly compound</b>	DT Swiss universal grease 20 g	HXTXXX00NMG20S	XB72
<b>Tools</b>	Toolset 350 15mm	HWTXXX00N5290S	XC10
	Mounting tool	HXTXXX00N9793S	XC11

Click on the part number to buy online. Hub spare parts are available exclusively to Orbea dealers through Kide (B2B access)

## OQUO DT SWISS INSIDE REAR HUBS

## Oquo LTD DT Swiss 240 Inside Straight Pull 12x148 28H Centerlock

See the OQUO wheel technical specifications table for your wheels' hub model

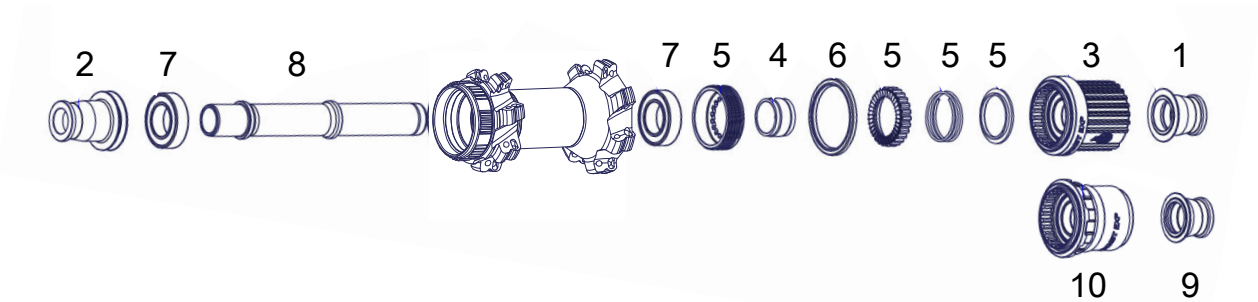

	DESCRIPTION	NUMBER PER HUB	ITEM No. DT SWISS	ITEM No. ORBEA
1	RW ADAPT WP XXX/12 R BM MS	1	HWAXXX00S2766S	<a href="#">XB87</a>
2	RW ADAPT WP XXX/12 L BM	1	HWAXXX00S2763S	<a href="#">XB88</a>
3	FB W MTB SHI MS EXP AL LI SL M	1	HWRABL00S4863S	<a href="#">XB89</a>
4	SPACER ALLOY 10.7 EXP	1	HRDXXX00N8242S	<a href="#">XB90</a>
5	SERVICE KIT RATCHET 36T EXP W/O TOOL	1	HWYXXX00N0042S	<a href="#">XB91</a>
6	SEAL HUB/ROTOR (diam 30x36x2.5 mm)	1	HSOXXX00N1031S	<a href="#">XB92</a>
7	B.BEARING 1526 ESB/ESNB L	2	HSBXXX00N3741S	<a href="#">XB93</a>
8	RW AXLE AL XXX mm diam 15/52.85 mm EXP	1	HCCXXX00S3303S	<a href="#">XB94</a>
9	RW ADAPT WP XXX/12 R BM SRAM XD	1	HWAXXX00S2767S	<a href="#">XB95</a>
10	FB W MTB SRA XD EXP AL ST SL M	1	HWRABL00S3830S	<a href="#">XB96</a>

	DESCRIPTION	ITEM No. DT SWISS	ITEM No. ORBEA
<b>Assembly compound</b>	DT Swiss universal grease 20 g	HXTXXX00NMG20S	<a href="#">XB72</a>
	DT Swiss special grease 20 g	HXT10032508S	<a href="#">XB97</a>
<b>Tools</b>	Installation cylinder 15x26x40 mm	HWTXXX00N5290S	<a href="#">XB98</a>
	Mounting/dismounting tool for the threaded ratchet	HXTXXX00N9793S	<a href="#">XB99</a>
	Mounting/dismounting tool ball bearing drive side	HWTXXX00N5290S	<a href="#">XC01</a>
	Installation tool for hub seal	HXTXXX00N9793S	<a href="#">XC02</a>

Click on the part number to buy online. Hub spare parts are available exclusively to Orbea dealers through Kide (B2B access)

## OQUO DT SWISS INSIDE REAR HUBS

## Oquo LTD DT Swiss 350 Inside Straight Pull 12x148 28/32H Centerlock/6-bolt

See the OQUO wheel technical specifications table for your wheels' hub model

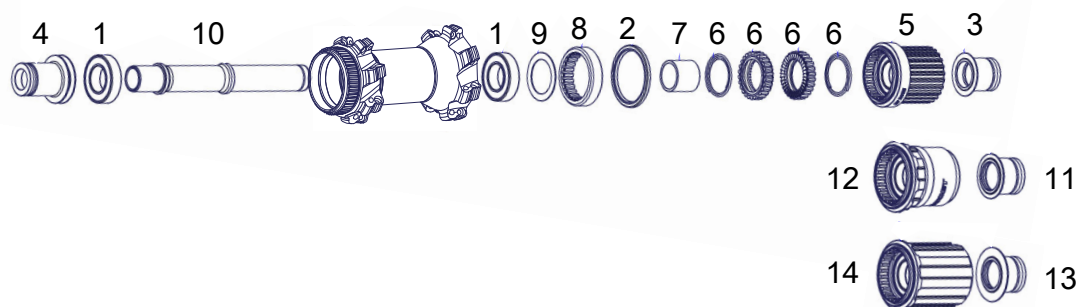

	DESCRIPTION	NUMBER PER HUB	ITEM No. DT SWISS	ITEM No. ORBEA
1	B.BEARING 6902 ESB/ESNB L	2	HSBXXX00N2336S	XC06
2	SEAL HUB/ROTOR (diam 30x36x2.5mm)	1	HSOXXX00N1031S	XB92
3	RW ADAPT WP XXX/12 R B MS	1	HWA00100S7912S	XC15
4	RW ADAPT WP XXX/12 L B	1	HWA00100S7841S	XC17
5	FB W MTB SHI MS RAT AL LI SL B	1	HWRABL00S2148S	XC19
6	SERVICE KIT RATCHET 36T	1	HWTXXX00NSK36S	XC20
7	SPACER ALLOY 15.4 mm BL	1	HCDXXX00S1077S	XC21
8	RING NUT STEEL M34X1 240	1	HXDXXX00N1131S	XC22
9	SHIM RING diam 28/20X0.5mm	1	HCDXXX00S1083S	XC23
10	RW AXLE AL 148mm diam 15/48.2mm	1	HCCXXX00S6450S	XC24
11	RW ADAPT WP XXX/12 R B SRAM XD	1	HWA00100S7513S	XC25
12	FB W MTB SRA XD RAT AL ST SL B	1	HWRAL00S3114S	XC26
13	RW ADAPT WP XXX/12 R B	1	HWA00100S7892S	XC27
14	FB W MTB SHI RAT AL LI	1	HWRABL00S1239S	XC28

	DESCRIPTION	ITEM No. DT SWISS	ITEM No. ORBEA
<b>Assembly compound</b>	DT Swiss universal grease 20 g	HXTXXX00NMG20S	XB72
	DT Swiss special grease 20 g	HXT10032508S	XB97
<b>Tools</b>	Installation cylinder 15x26x40 mm	HWTXXX00N5290S	XB98
	Installation tool for hub seal	HXTXXX00N1000S	XC02
	Tool for ring nut	HXTXXX00N5027S	XC32

Click on the part number to buy online. Hub spare parts are available exclusively to Orbea dealers through Kide (B2B access)

## OQUO DT SWISS INSIDE REAR HUBS

## Oquo LTD DT Swiss Inside 350 DEG J-bend 12x148 32H 6-bolt

See the OQUO wheel technical specifications table for your wheels' hub model

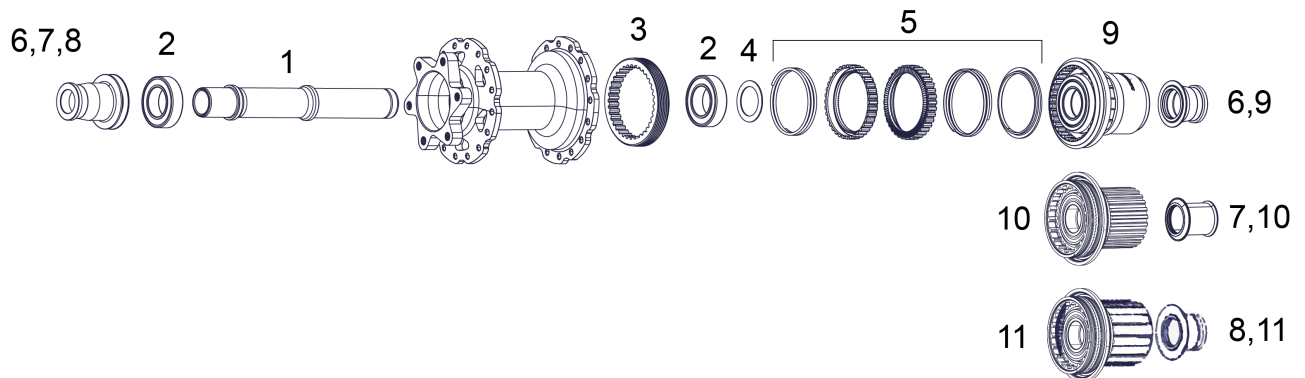

	DESCRIPTION	NUMBER PER HUB	ITEM No. DT SWISS	ITEM No. ORBEA
1	RW AXLE AL 148mm diam 15/48.2mm	1	HCCXXX00S6450S	<a href="#">XC24</a>
2	B.BEARING 6902 ESB/ESNB L	2	HSBXXX00N2336S	<a href="#">XC06</a>
3	RING NUT ST M45X2-2MM DEG	1	HXDXXX00N9037S	<a href="#">XJ88</a>
4	SPACER ALLOY 2.95mm N	1	HCD14200N9313S	<a href="#">XJ89</a>
5	SERVICE KIT RATCHET 72T DEG	1	HWYXXX00N6599S	<a href="#">XJ90</a>
6	RW ADAPT KIT 142/Ø12 240 SRAM XD (ONLY CAPS)	1	HWGXXX00S3188S	<a href="#">X649</a>
7	RW ADAPT KIT XXX/12 B MS (ONLY CAPS)	1	HWGXXX00S5643S	<a href="#">X647</a>
8	CONVERSION KIT X12 HG (ONLY CAPS)	1	HWGXXX0002193C	<a href="#">X648</a>
9	FB K MTB SRA XD DEG 12/148 AL ST SL B	1	HWYABL00S2779S	<a href="#">XJ91</a>
10	FB K MTB SHI MS DEG 12/148 AL ST SL B	1	HWYABL00S2787S	<a href="#">XJ92</a>
11	FB K MTB SHI DEG 12/148 AL ST SL B	1	HWYABL00S2786S	<a href="#">XJ93</a>

	DESCRIPTION	ITEM No. DT SWISS	ITEM No. ORBEA
<b>Assembly compound</b>	DT Swiss universal grease 20 g	HXTXXX00NMG20S	<a href="#">XB72</a>
	DT Swiss special grease 20 g	HXT10032508S	<a href="#">XB97</a>
<b>Tools</b>	Installation cylinder 15x26x40 mm	HWTXXX00N5290S	<a href="#">XB98</a>
	Installation cylinder diam 15 / 28 x 35 mm	HXTXXX00N5024S	<a href="#">XC02</a>
	tool for ring nut DEG	HXTXXX00N2612S	<a href="#">XJ94</a>

Click on the part number to buy online. Hub spare parts are available exclusively to Orbea dealers through Kide (B2B access)

**SPARE PARTS FOR DT SWISS HUBS**

See the OQUO wheel technical specifications table for your wheels' hub model

**DT SWISS FRONT HUBS****DT Swiss 240 J-bend 15x110 24/28H Centerlock/6-bolt**

See the OQUO wheel technical specifications table for your wheels' hub model

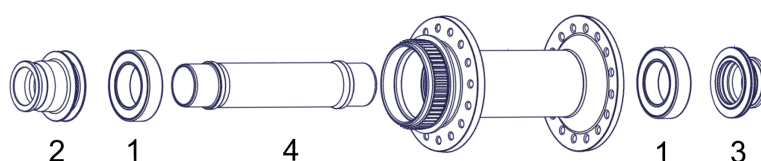

	DESCRIPTION	NUMBER PER HUB	ITEM No. DT DT SWISS	ITEM No. ORBEA
1	B.BEARING 1728 ESB/ESNB L	2	HSBXXX00N9115S	<a href="#">XB68</a>
2	FW ADAPT WP XXX/15 L BM DISC	1	HWAXXX00S2760S	<a href="#">XB69</a>
3	FW ADAPT WP XXX/15 R BM DISC	1	HWAXXX00S2761S	<a href="#">XB70</a>
4	FW AXLE AL 110 mm diam 17/64.3 mm	1	HRCXXX00N3296S	<a href="#">XB71</a>

	DESCRIPTION	ITEM No. DT SWISS	ITEM No. ORBEA
<b>Assembly compound</b>	DT Swiss universal grease 20 g	HXTXXX00NMG20S	<a href="#">XB72</a>
<b>Tools</b>	Installation cylinder diam 17 / 28mm x 40mm	HXTXXX00N9345S	<a href="#">XB73</a>
	Axle tool diam 17 mm	HXTXXX00N5067S	<a href="#">XB74</a>

Click on the part number to buy online. Hub spare parts are available exclusively to Orbea dealers through Kide (B2B access)

## DT SWISS FRONT HUBS

## DT Swiss 350 J-bend 15x110 28H Centerlock/6-bolt

See the OQUO wheel technical specifications table for your wheels' hub model

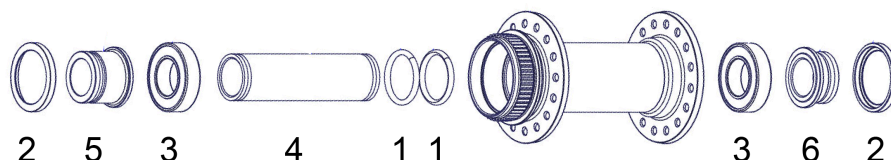

	DESCRIPTION	NUMBER PER HUB	ITEM No. DT SWISS	ITEM No. ORBEA
1	O-RING diam 18X2.5mm NBR 70 SHORE ISO3601	2	HSOXXX00X2164S	XC04
2	FW COVER FOR TA15 mm	2	HCD00100S4603S	XC05
3	B.BEARING 6902 ESB/ESNB L	2	HSBXXX00N2336S	XC06
4	SPACER diam 15mm x 67.2mm	1	HXD00000N6567C	XC07
5	FW ADAPT SP XXX/15 L B	1	HCA00100S7745S	XC08
6	FW ADAPT SP XXX/15 R B	1	HCA00100S7744S	XC09

	DESCRIPTION	ITEM No. DT SWISS	ITEM No. ORBEA
<b>Assembly compound</b>	DT Swiss universal grease 20 g	HXTXXX00NMG20S	XB72
<b>Tools</b>	Toolset 350 15mm	HWTXXX00N5290S	XC10
	Mounting tool	HXTXXX00N9793S	XC11

Click on the part number to buy online. Hub spare parts are available exclusively to Orbea dealers through Kide (B2B access)

**DT SWISS FRONT HUBS****DT Swiss 350 J-bend 20x110 28H 6-bolt**

See the OQUO wheel technical specifications table for your wheels' hub model

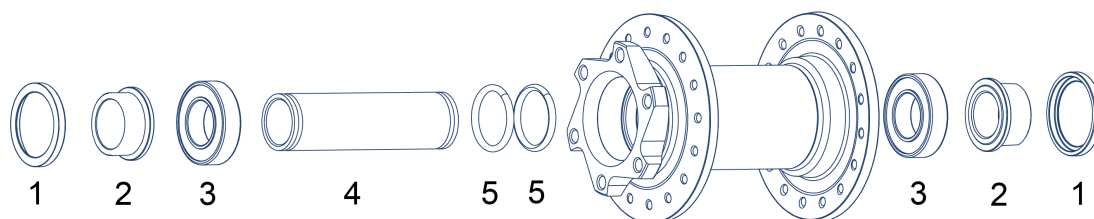

	DESCRIPTION	NUMBER PER HUB	ITEM No. DT SWISS	ITEM No. ORBEA
1	FW COVER FOR TA20mm	2	HCDXXX00S1461S	XJ95
2	FW ADAPT SP 110X DBIS TA20 B	2	HCAXXX00S6824S	XJ96
3	B.BEARING 6904 ESB/ESNB L	2	HSBXXX00N1414S	XJ97
4	FW SPACER 65.1x25MM	1	HXDXXX00N6823S	XJ98
5	O-RING diam 18X2.5mm NBR 70 SHORE ISO3601	2	HSOXXX00X2164S	XC04

	DESCRIPTION	ITEM No. DT SWISS	ITEM No. ORBEA
<b>Assembly compound</b>	DT Swiss universal grease 20 g	HXTXXX00NMG20S	XB72
<b>Tools</b>	Toolset 350 20mm	HWTXXX00N5292S	—
	Mounting tool	HXTXXX00N9793S	XC11

Click on the part number to buy online. Hub spare parts are available exclusively to Orbea dealers through Kide (B2B access)

## DT SWISS FRONT HUBS

## DT Swiss 370 J-bend 15x110 28H 6-bolt

See the OQUO wheel technical specifications table for your wheels' hub model

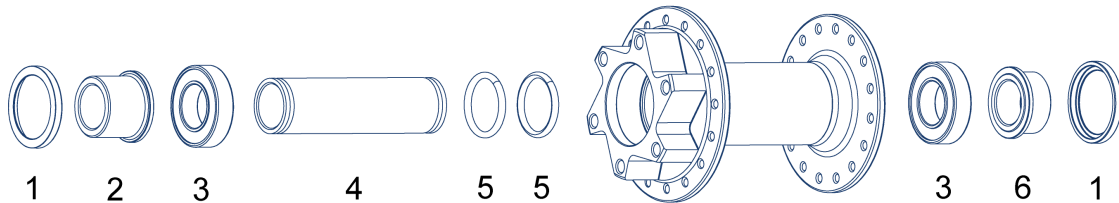

	DESCRIPTION	NUMBER PER HUB	ITEM No. DT SWISS	ITEM No. ORBEA
1	FW COVER FOR TA15MM	2	HCD00100S4603S	<a href="#">XC05</a>
2	FW ADAPT SP 100L DBCL SA15 S	1	HCA00100S4601S	<a href="#">XC48</a>
3	B.BEARING 6902 ESB/ESNB L	2	HSBXXX00N2336S	<a href="#">XC06</a>
4	SPACER Ø15MM x 67.2MM	1	HXD00000N6567C	<a href="#">XC07</a>
5	O-RING Ø18X2.5MM NBR 70 SHORE ISO3601	2	HSOXXX00X2164S	<a href="#">XC04</a>
6	FW ADAPT SP 100R DBCL SA15 S	1	HCA00100S4602S	<a href="#">XC47</a>

	DESCRIPTION	ITEM No. DT SWISS	ITEM No. ORBEA
<b>Assembly compound</b>	DT Swiss universal grease 20 g	HXTXXX00NMG20S	<a href="#">XB72</a>
<b>Tools</b>	Toolset 350 15mm	HWTXXX00N5290S	<a href="#">XC10</a>
	Mounting tool	HXTXXX00N9793S	<a href="#">XC11</a>

Click on the part number to buy online. Hub spare parts are available exclusively to Orbea dealers through Kide (B2B access)

**DT SWISS FRONT HUBS****DT Swiss 350 Hybrid J-bend 15x110 32H 6-bolt (up to MY2023)**

See the OQUO wheel technical specifications table for your wheels' hub model

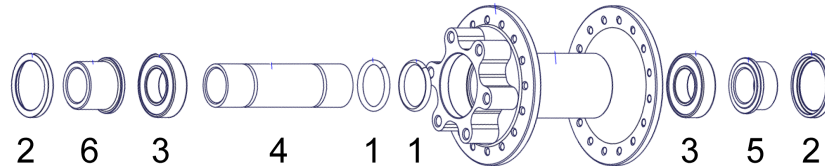

	DESCRIPTION	NUMBER PER HUB	ITEM No. DT SWISS	ITEM No. ORBEA
1	O-RING diam 18X2.5mm NBR 70 SHORE ISO3601	2	HSOXXX00X2164S	XC04
2	FW COVER FOR TA15 mm	2	HCD00100S4603S	XC05
3	B.BEARING 6902 ESB/ESNB L	2	HSBXXX00N2336S	XC06
4	SPACER diam 15mm x 67.2M	1	HXD00000N6449S	XC46
5	FW ADAPT SP 100R DBCL SA15 S	1	HCA00100S4602S	XC47
6	FW ADAPT SP 100L DBCL SA15 S	1	HCA00100S4601S	XC48

	DESCRIPTION	ITEM No. DT SWISS	ITEM No. ORBEA
<b>Assembly compound</b>	DT Swiss universal grease 20 g	HXTXXX00NMG20S	XB72
<b>Tools</b>	Toolset 350 15mm	HWTXXX00N5290S	XC10
	Mounting tool	HXTXXX00N9793S	XC11

Click on the part number to buy online. Hub spare parts are available exclusively to Orbea dealers through Kide (B2B access)

**DT SWISS FRONT HUBS****DT Swiss 350 Hybrid J-bend 15x110 28H 6-bolt (from MY2024)**

See the OQUO wheel technical specifications table for your wheels' hub model

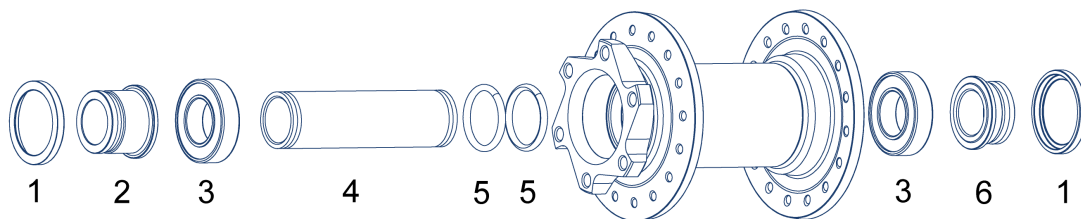

	DESCRIPTION	NUMBER PER HUB	ITEM No. DT SWISS	ITEM No. ORBEA
1	FW COVER FOR TA15 mm	2	HCD00100S4603S	XC05
2	FW ADAPT SP XXX/15 L B	1	HCA00100S7745S	XC08
3	B.BEARING 6902 ESB/ESNB L	2	HSBXXX00N2336S	XC06
4	SPACER Ø15MM x 67.2MM	1	HXD00000N6567C	XC07
5	O-RING diam 18X2.5mm NBR 70 SHORE ISO3601	2	HSOXXX00X2164S	XC04
6	FW ADAPT SP XXX/15 R B	1	HCA00100S7744S	XC09

	DESCRIPTION	ITEM No. DT SWISS	ITEM No. ORBEA
<b>Assembly compound</b>	DT Swiss universal grease 20 g	HXTXXX00NMG20S	XB72
<b>Tools</b>	Toolset 350 15mm	HWTXXX00N5290S	XC10
	Mounting tool	HXTXXX00N9793S	XC11

Click on the part number to buy online. Hub spare parts are available exclusively to Orbea dealers through Kide (B2B access)

## DT SWISS REAR HUBS

## DT Swiss 240 J-bend 12x148 28H Centerlock

See the OQUO wheel technical specifications table for your wheels' hub model

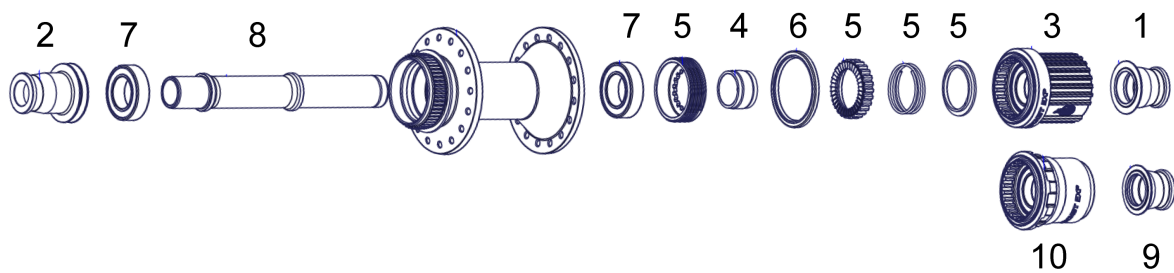

	DESCRIPTION	NUMBER PER HUB	ITEM No. DT SWISS	ITEM No. ORBEA
1	RW ADAPT WP XXX/12 R BM MS	1	HWAXXX00S2766S	<a href="#">XB87</a>
2	RW ADAPT WP XXX/12 L BM	1	HWAXXX00S2763S	<a href="#">XB88</a>
3	FB W MTB SHI MS EXP AL LI SL M	1	HWRABL00S4863S	<a href="#">XB89</a>
4	SPACER ALLOY 10.7 EXP	1	HRDXXX00N8242S	<a href="#">XB90</a>
5	SERVICE KIT RATCHET 36T EXP W/O TOOL	1	HWYXXX00N0042S	<a href="#">XB91</a>
6	SEAL HUB/ROTOR (diam 30x36x2.5 mm)	1	HSOXXX00N1031S	<a href="#">XB92</a>
7	B.BEARING 1526 ESB/ESNB L	2	HSBXXX00N3741S	<a href="#">XB93</a>
8	RW AXLE AL XXX mm diam 15/52.85 mm EXP	1	HCCXXX00S3303S	<a href="#">XB94</a>
9	RW ADAPT WP XXX/12 R BM SRAM XD	1	HWAXXX00S2767S	<a href="#">XB95</a>
10	FB W MTB SRA XD EXP AL ST SL M	1	HWRABL00S3830S	<a href="#">XB96</a>

	DESCRIPTION	ITEM No. DT SWISS	ITEM No. ORBEA
<b>Assembly compound</b>	DT Swiss universal grease 20 g	HXTXXX00NMG20S	<a href="#">XB72</a>
	DT Swiss special grease 20 g	HXT10032508S	<a href="#">XB97</a>
<b>Tools</b>	Installation cylinder 15x26x40 mm	HWTXXX00N5290S	<a href="#">XB98</a>
	Mounting/dismounting tool for the threaded ratchet	HXTXXX00N9793S	<a href="#">XB99</a>
	Mounting/dismounting tool ball bearing drive side	HWTXXX00N5290S	<a href="#">XC01</a>
	Installation tool for hub seal	HXTXXX00N9793S	<a href="#">XC02</a>

Click on the part number to buy online. Hub spare parts are available exclusively to Orbea dealers through Kide (B2B access)

**DT SWISS REAR HUBS****DT Swiss 350 J-bend 12x148 28/32H Centerlock/6-bolt**

See the OQUO wheel technical specifications table for your wheels' hub model

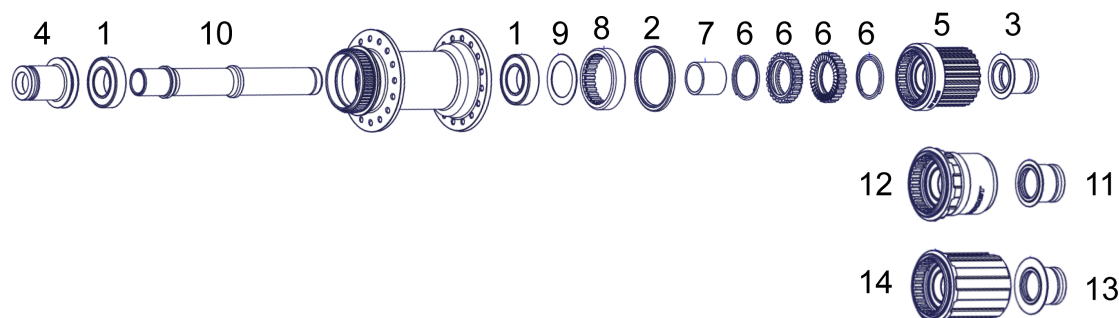

	DESCRIPTION	NUMBER PER HUB	ITEM No. DT SWISS	ITEM No. ORBEA
1	B.BEARING 6902 ESB/ESNB L	2	HSBXXX00N2336S	<a href="#">XC06</a>
2	SEAL HUB/ROTOR (diam 30x36x2.5mm)	1	HSOXXX00N1031S	<a href="#">XB92</a>
3	RW ADAPT WP XXX/12 R B MS	1	HWA00100S7912S	<a href="#">XC15</a>
4	RW ADAPT WP XXX/12 L B	1	HWA00100S7841S	<a href="#">XC17</a>
5	FB W MTB SHI MS RAT AL LI SL B	1	HWRABL00S2148S	<a href="#">XC19</a>
6	SERVICE KIT RATCHET 36T SL	1	HWTXXX00NSK36S	<a href="#">XC20</a>
7	SPACER ALLOY 15.4 mm BL	1	HCDXXX00S1077S	<a href="#">XC21</a>
8	RING NUT STEEL M34X1 240	1	HXDXXX00N1131S	<a href="#">XC22</a>
9	SHIM RING diam 28/20X0.5mm	1	HCDXXX00S1083S	<a href="#">XC23</a>
10	RW AXLE AL 148mm diam 15/48.2mm	1	HCCXXX00S6450S	<a href="#">XC24</a>
11	RW ADAPT WP XXX/12 R B SRAM XD	1	HWA00100S7513S	<a href="#">XC25</a>
12	FB W MTB SRA XD RAT AL ST SL B	1	HWRAAL00S3114S	<a href="#">XC26</a>
13	RW ADAPT WP XXX/12 R B	1	HWA00100S7892S	<a href="#">XC27</a>
14	FB W MTB SHI RAT AL LI SL B	1	HWRABL00S1239S	<a href="#">XC28</a>

	DESCRIPTION	ITEM No. DT SWISS	ITEM No. ORBEA
<b>Assembly compound</b>	DT Swiss universal grease 20 g	HXTXXX00NMG20S	<a href="#">XB72</a>
	DT Swiss special grease 20 g	HXT10032508S	<a href="#">XB97</a>
<b>Tools</b>	Installation cylinder 15x26x40 mm	HWTXXX00N5290S	<a href="#">XB98</a>
	Installation tool for hub seal	HXTXXX00N1000S	<a href="#">XC02</a>
	Tool for ring nut	HXTXXX00N5027S	<a href="#">XC32</a>

Click on the part number to buy online. Hub spare parts are available exclusively to Orbea dealers through Kide (B2B access)

## DT SWISS REAR HUBS

## DT Swiss 370 J-bend 12x148 28H 6-bolt

See the OQUO wheel technical specifications table for your wheels' hub model

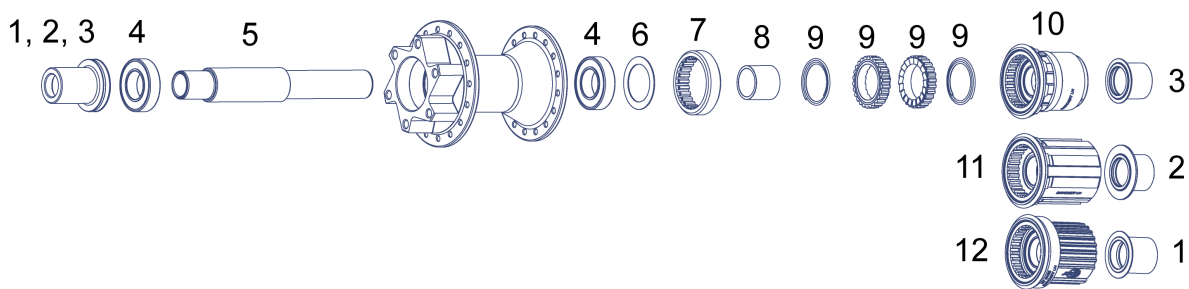

	DESCRIPTION	NUMBER PER HUB	ITEM No. DT SWISS	ITEM No. ORBEA
1	RW ADAPT KIT XXX/12 B MS	1	HWGXXX00S5643S	X647
2	CONVERSION KIT X12 HG	2	HWGXXX0002193C	X648
3	RW ADAPT KIT 142/Ø12 240 SRAM XD	1	HWGXXX00S3188S	X649
4	B.BEARING 6902 ESB/ESNB M	1	HSBXXX00N3221S	XC06
5	RW AXLE AL 148mm diam 15/48.2mm	1	HCCXXX00S6450S	XC24
6	SHIM RING diam 28/20X0.5mm	1	HCDXXX00S1083S	XC23
7	RING NUT STEEL M34X1 240	2	HXDXXX00N1131S	XC22
8	SPACER ALLOY 15.4 (ROTOR S)	2	HRDXXX00N4636S	XC35
9	SERVICE KIT H240/240S/FR/440	1	HWTXXX00NSK24S	X650
10	FB K MTB SRA XD LN 12/142/48 AL ST SM B	1	HWYABM00S3766S	X651
11	FB K MTB SHI LN 12/142/48 AF ST SM B	1	HWYABM00S3764S	X653
12	FB K MTB SHI MS LN 12/142/48 AL LI SM B	1	HWYABM00S3765S	X652

	DESCRIPTION	ITEM No. DT SWISS	ITEM No. ORBEA
<b>Assembly compound</b>	DT Swiss universal grease 20 g	HXTXXX00NMG20S	XB72
	DT Swiss special grease 20 g	HXT10032508S	XB97
<b>Tools</b>	Installation cylinder 15x26x40 mm	HWTXXX00N5290S	XB98
	Installation tool for hub seal	HXTXXX00N1000S	XC02
	Tool for ring nut	HXTXXX00N5027S	XC32

Click on the part number to buy online. Hub spare parts are available exclusively to Orbea dealers through Kide (B2B access)

**DT SWISS REAR HUBS****DT Swiss 350 Hybrid J-bend 12x148 32H 6-bolt (up to MY2023)**

See the OQUO wheel technical specifications table for your wheels' hub model

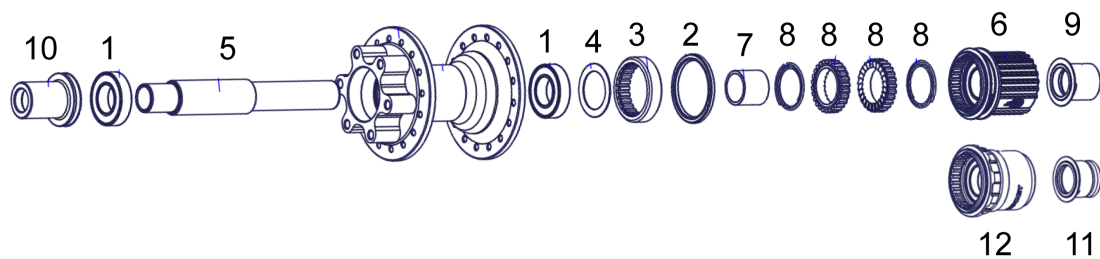

	DESCRIPTION	NUMBER PER HUB	ITEM No. DT SWISS	ITEM No. ORBEA
1	B.BEARING 6902 ESB/ESNB L	2	HSBXXX00N2336S	<a href="#">XC06</a>
2	SEAL HUB/ROTOR (diam 30x36x2.5 mm)	1	HSOXXX00N1031S	<a href="#">XB92</a>
3	RING NUT STEEL M34X1 240	1	HXDXXX00N1131S	<a href="#">XC22</a>
4	SHIM RING diam 28/20X0.5 mm	1	HCDXXX00S1083S	<a href="#">XC23</a>
5	RW AXLE AL 148 mm diam 15/48.2 mm	1	HCCXXX00S6450S	<a href="#">XC24</a>
6	FB W MHY SHI MS RAT ST ST SL B	1	HWRABL00S0758S	<a href="#">XC34</a>
7	SPACER ALLOY 15.4 (ROTOR S)	1	HRDXXX00N4636S	<a href="#">XC35</a>
8	SERVICE KIT RATCHET 24T	1	HWTXXX00NSKTFS	<a href="#">XC36</a>
9	RW ADAPT WP XXXR TA12 B MS	1	HWAXXX00S0491S	<a href="#">XC37</a>
10	RW ADAPT WP 142L DBIS SA12 S	1	HWA00100S2193C	<a href="#">XC38</a>
11	RW ADAPT WP XXXR TA12 B SRAM XD	1	HWAXXX00S3188S	<a href="#">XC39</a>
12	FB W MHY SRA XD RAT ST ST SL B	1	HWRAXL00S3224S	<a href="#">XC40</a>

	DESCRIPTION	ITEM No. DT SWISS	ITEM No. ORBEA
<b>Assembly compound</b>	DT Swiss universal grease 20 g	HXTXXX00NMG20S	<a href="#">XB72</a>
	DT Swiss special grease 20 g	HXT10032508S	<a href="#">XB97</a>
<b>Tools</b>	Installation tool for hub seal	HXTXXX00N1000S	<a href="#">XC02</a>
	Tool for ring nut	HXTXXX00N5027S	<a href="#">XC32</a>
	Installation cylinder diam 15 / 28 x 35 mm	HXTXXX00N5024S	<a href="#">XC41</a>

Click on the part number to buy online. Hub spare parts are available exclusively to Orbea dealers through Kide (B2B access)

## DT SWISS REAR HUBS

## DT Swiss 350 Hybrid J-bend 12x148 32H 6-bolt (from MY2024)

See the OQUO wheel technical specifications table for your wheels' hub model

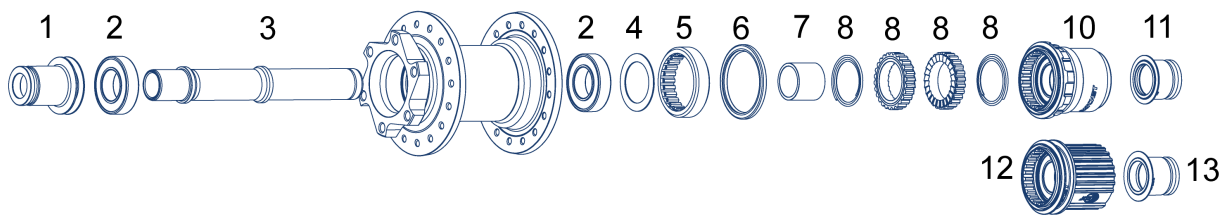

	DESCRIPTION	NUMBER PER HUB	ITEM No. DT SWISS	ITEM No. ORBEA
1	RW ADAPT WP XXX/12 L B	1	HWA00100S7841S	XC17
2	B.BEARING 6902 ESB/ESNB L	2	HSBXXX00N2336S	XC06
3	RW AXLE AL 148MM Ø15/48.2MM	1	HCCXXX00S6450S	XC24
4	SHIM RING Ø28/20X0.5MM	1	HCDXXX00S1083S	XC23
5	RING NUT STEEL M34X1 240	1	HXDXXX00N1131S	XC22
6	SEAL HUB/ROTOR (Ø30x36x2.5 mm)	1	HSOXXX00N1031S	XB92
7	SPACER ALLOY 15.4 mm BL	1	HCDXXX00S1077S	XC21
8	SERVICE KIT RATCHET 24T	1	HWTXXX00NSKTFS	XC36
10	FB W MHY SRA XD RAT ST ST SL B	1	HWRAXL00S3224S	XC40
11	RW ADAPT WP XXX/12 R B SRAM XD	1	HWA00100S7513S	XC25
12	FB W MHY SHI MS RAT ST ST SL B	1	HWRABL00S3226S	XC34
13	RW ADAPT WP XXX/12 R B MS	1	HWA00100S7912S	XC15

	DESCRIPTION	ITEM No. DT SWISS	ITEM No. ORBEA
<b>Assembly compound</b>	DT Swiss universal grease 20 g	HXTXXX00NMG20S	XB72
	DT Swiss special grease 20 g	HXT10032508S	XB97
<b>Tools</b>	Installation tool for hub seal	HXTXXX00N1000S	XC02
	Tool for ring nut	HXTXXX00N5027S	XC32
	Installation cylinder diam 15 / 28 x 35 mm	HXTXXX00N5024S	XC41

Click on the part number to buy online. Hub spare parts are available exclusively to Orbea dealers through Kide (B2B access)

## SPOKES. OQUO WHEEL SPOKE KITS

## MOUNTAIN PERFORMANCE (MP)

WHEEL MODEL	FRONT / REAR	HUB	DESCRIPTION SPARE PART	INCLUDES	QUANT.	CODE ART. ORBEA
MP30 LTD V1 up to MY2024	FRONT 29" 24H	DT SWISS 240 CLASSIC 24H	SPOKE + SPOKE NIPPLES KIT MP30LTD FRONT 24H V1	Sapim CX-Ray TCS Aero. 14G (2mm). J-Bend. 293 mm. Black	2	XB61
				Sapim CX-Ray TCS Aero. 14G (2 mm). J-Bend. 291 mm. Black	2	
				Sapim Alloy Double Square 2 x 18 mm. Black	4	
	FRONT 29" 28H	DT SWISS 240 CLASSIC 28H	SPOKE + SPOKE NIPPLES KIT MP30LTD FRONT 28H V1	Sapim CX-Ray TCS Aero. 14G (2 mm). J-Bend. 299 mm. Black	2	XB65
				Sapim CX-Ray TCS Aero. 14G (2 mm). J-Bend. 297 mm. Black	2	
				Sapim Alloy Double Square 2 x 18 mm. Black	4	
	REAR 29" 28H	DT SWISS 240 CLASSIC 28H	SPOKE + SPOKE NIPPLES KIT MP30LTD REAR 28H V1	Sapim CX-Ray TCS Aero. 14G (2 mm). J-Bend. 295 mm. Black	2	XB86
				Sapim CX-Ray TCS Aero. 14G (2 mm). J-Bend. 296 mm. Black	2	
				Sapim Alloy Double Square 2 x 18 mm. Black	4	
MP30 LTD V2 from MY2025	FRONT 29" 24H	OQUO LTD SP DT SWISS INSIDE 240 24H	SPOKE + SPOKE NIPPLES KIT MP30LTD FRONT 24H V2	DT aerolite T-shape Straightpull 2.0-(0.9x2.2)-2mm. 301mm. Black	4	XH58
				DT Alloy Double Square 2x15mm.	4	
	REAR 29" 28H	OQUO LTD SP DT SWISS INSIDE 240 28H	SPOKE + SPOKE NIPPLES KIT MP30LTD REAR 28H V2	DT aerolite T-shape Straightpull 2.0-(0.9x2.2)-2mm. 304mm. Black	4	XH59
				DT Alloy Double Square 2x15mm.	4	
MP30 TEAM V1 up to MY2024	FRONT 29" 28H	DT SWISS 350 CLASSIC 28H	SPOKE + SPOKE NIPPLES KIT MP30TEAM FRONT 28H V1	Sapim D-Sprint. Butted. 14G (2mm).J-Bend. 298m. Black	2	XC03
				Sapim D-Sprint. Butted. 14G (2mm).J-Bend. 297m. Black	2	
				Sapim Brass Polyax 2 x 14 mm. Black	4	
	REAR 29" 28H	DT SWISS 350 CLASSIC 28H	SPOKE + SPOKE NIPPLES KIT MP30TEAM REAR 28H V1	Sapim D-Sprint. Butted. 14G (2mm).J-Bend. 294m. Black	2	XC12
				Sapim D-Sprint. Butted. 14G (2mm).J-Bend. 295m. Black	2	
				Sapim Brass Polyax 2 x 14 mm. Black	4	
MP30 TEAM V2 from MY2025	FRONT 29" 28H	OQUO TEAM SP DT SWISS INSIDE 350 28H	SPOKE + SPOKE NIPPLES KIT MP30 TEAM FRONT 28H V2	Sapim Sprint SP Butted 2.0/1.7/2.0 305mm. Black	4	XH61
				Sapim Alloy Double Square 2 x 18 mm. Black	4	
	REAR 29" 28H	OQUO TEAM SP DT SWISS INSIDE 350 28H	SPOKE + SPOKE NIPPLES KIT MP30 TEAM REAR 28H V2	Sapim Sprint SP Butted 2.0/1.7/2.0 304mm. Black	4	XH62
				Sapim Alloy Double Square 2 x 18 mm. Black	4	
MP28 PRO up to MY2023	FRONT 29" 28H	DT SWISS 350 CLASSIC 28H	SPOKE + SPOKE NIPPLES KIT MP28PRO FRONT 28H V1	Sapim Race. Butted. 14G (2mm).J-Bend. 298mm. Black	2	XC33
				Sapim Race. Butted. 14G (2 mm). J-Bend. 297 mm. Black	2	
				Sapim Brass Polyax 2 x 14 mm. Black	4	
	REAR 29" 28H	DT SWISS 350 CLASSIC 28H	SPOKE + SPOKE NIPPLES KIT MP28PRO REAR 28H V1	Sapim Race. Butted. 14G (2mm).J-Bend. 296mm. Black	2	XC14
				Sapim Race. Butted. 14G (2 mm). J-Bend. 297 mm. Black	2	
				Sapim Brass Polyax 2 x 14 mm. Black	4	
MP28 PRO from MY2024	FRONT 29" 28H	DT SWISS 370 CLASSIC 28H	SPOKE + SPOKE NIPPLES KIT MP28PRO FRONT 28H V2	Sapim Race. Butted. 14G (2 mm). J-Bend. 297 mm. Black	2	XD46
				Sapim Race. Butted. 14G (2 mm). J-Bend. 296 mm. Black	2	
				Sapim Brass Polyax 2 x 14 mm. Black	4	
	REAR 29" 28H	DT SWISS 370 CLASSIC 28H	SPOKE + SPOKE NIPPLES KIT MP28PRO REAR 28H V2	Sapim Race. Butted. 14G (2 mm). J-Bend. 296 mm. Black	2	XD47
				Sapim Race. Butted. 14G (2 mm). J-Bend. 296 mm. Black	2	
				Sapim Brass Polyax 2 x 14 mm. Black	4	

Click on the part number to buy online.

## SPOKES. OQUO WHEEL SPOKE KITS

## MOUNTAIN CONTROL (MC)

WHEEL MODEL	FRONT / REAR	HUB	DESCRIPTION SPARE PART	INCLUDES	QUANT.	CODE ART. ORBEA
MC32 LTD V1 up to MY2025	FRONT 29" 28H	DT SWISS 350 CLASSIC 28H	SPOKE + SPOKE NIPPLES KIT MC32LTD FRONT 28H V1	Sapim D-Sprint. Butted. 14G (2mm).J-Bend. 298m. Black	2	XC29
				Sapim D-Sprint. Butted. 14G (2 mm). J-Bend. 301 m. Black	2	
				Sapim Brass Polyax 2 x 14 mm. Black	4	
	REAR 29" 32H	DT SWISS 350 CLASSIC 32H	SPOKE + SPOKE NIPPLES KIT MC32LTD REAR 32H V1	Sapim Race. Butted 14G (2mm).J-Bend. 292mm. Black	4	XC30
Sapim Brass Polyax 2 x 14 mm. Black				4		
MC32 LTD V2 from MY2026	FRONT 29" 28H	OQUO LTD JBEND 28H DT INSIDE 350	SPOKE + SPOKE NIPPLES KIT MC32LTD FRONT 28H V2	Sapim Sprint. Butted. 14G (2mm).J-Bend. 299 mm. Black	4	XJ99
				Sapim Brass Polyax 2 x 14 mm. Black	4	
	REAR 29" 32H	OQUO LTD JBEND 32H DT INSIDE 350 DEG	SPOKE + SPOKE NIPPLES KIT MC32LTD REAR 32H V2	Sapim Race. Butted 14G (2mm).J-Bend. 291 mm. Black	4	XK00
				Sapim Brass Polyax 2 x 14 mm. Black	4	
MC32 TEAM V1 up to MY2024	FRONT 29" 28H	DT SWISS 350 CLASSIC 28H	SPOKE + SPOKE NIPPLES KIT MC32TEAM TEAM FRONT 28H V1	Sapim D-Sprint. Butted. 14G (2mm).J-Bend. 299 mm. Black	2	XC42
				Sapim D-Sprint. Butted. 14G (2 mm). J-Bend. 297 m. Black	2	
				Sapim Brass Polyax 2 x 14 mm. Black	4	
	REAR 29" 32H	DT SWISS 350 CLASSIC 32H	SPOKE + SPOKE NIPPLES KIT MC32TEAM REAR 29 32H V1	Sapim Race. Butted 14G (2mm).J-Bend. 291 mm. Black	4	XC43
				Sapim Brass Polyax 2 x 14 mm. Black	4	
	REAR 27.5" 32H	DT SWISS 350 CLASSIC 32H	SPOKE + SPOKE NIPPLES KIT MC32TEAM REAR 27.5 32H V1	Sapim Race. Butted 14G (2mm).J-Bend. 271 mm. Black	4	XC44
Sapim Brass Polyax 2 x 14 mm. Black				4		
MC32 TEAM V2 MY2025	FRONT 29" 28H	DT SWISS 350 CLASSIC 28H	SPOKE + SPOKE NIPPLES KIT MC32 TEAM FRONT 28H V2	Sapim D-Light Butted. 14G (2 mm). J-Bend. 302 mm. Black	2	XH63
				Sapim D-Light Butted. 14G (2 mm). J-Bend. 300 mm. Black	2	
				Sapim Alloy Double Square 2 x 18 mm. Black	4	
	REAR 29" 32H	DT SWISS 350 CLASSIC 32H	SPOKE + SPOKE NIPPLES KIT MC32 TEAM REAR 29 32H V2	Sapim Sprint. Butted. 14G (2mm).J-Bend. 295 mm. Black	4	XH64
				Sapim Alloy Double Square 2 x 18 mm. Black	4	
	REAR 27.5" 32H	DT SWISS 350 CLASSIC 32H	SPOKE + SPOKE NIPPLES KIT MC32 TEAM REAR 27.5 32H V2	Sapim Sprint. Butted. 14G (2mm).J-Bend. 276 mm. Black	4	XH65
Sapim Alloy Double Square 2 x 18 mm. Black				4		
MC32 TEAM V3 from MY2026	FRONT 29" 28H	OQUO LTD JBEND 28H DT INSIDE 350	SPOKE + SPOKE NIPPLES KIT MC32 TEAM FRONT 28H V3	Sapim D-Light. Butted. 14G (2mm).J-Bend. 298mm. Black	2	XK02
				Sapim D-Light. Butted. 14G (2mm).J-Bend. 297mm. Black	2	
				Sapim Alloy Double Square 2 x 18 mm. Black	4	
	REAR 29" 32H	OQUO LTD JBEND 32H DT INSIDE 350 DEG	SPOKE + SPOKE NIPPLES KIT MC32 TEAM REAR 29 32H V3	Sapim Sprint. Butted. 14G (2 mm). J-Bend. 291 m. Black	4	XK03
				Sapim Alloy Double Square 2 x 18 mm. Black	4	
	REAR 27.5" 32H	OQUO LTD JBEND 32H DT INSIDE 350 DEG	SPOKE + SPOKE NIPPLES KIT MC32 TEAM REAR 27.5 32H V3	Sapim Sprint. Butted. 14G (2 mm). J-Bend. 272 m. Black	4	XK04
Sapim Alloy Double Square 2 x 18 mm. Black				4		
MC32 TEAM RALLON DH (OEM) from MY2026	FRONT 29" 28H	DT SWISS 350 CLASSIC 28H	SPOKE + SPOKE NIPPLES KIT MC32 TEAM RALLON DH FRONT 28H (OEM) V1	Sapim Race. Butted. 14G (2mm).J-Bend. 296mm. Black	4	XK05
				Sapim Brass Polyax 2 x 14 mm. Black	4	
	REAR 27.5" 32H	DT SWISS 350 CLASSIC 32H	SPOKE + SPOKE NIPPLES KIT MC32 TEAM RALLON DH REAR 27.5 32H (OEM) V1	Sapim Race. Butted. 14G (2mm).J-Bend. 272mm. Black	4	XK06
				Sapim Brass Polyax 2 x 14 mm. Black	4	

## SPOKES. OQUO WHEEL SPOKE KITS

## MOUNTAIN CONTROL (MC) POWER

WHEEL MODEL	FRONT / REAR	HUB	DESCRIPTION SPARE PART	INCLUDES	QUANT.	CODE ART. ORBEA
MC32 LTD POWER up to MY2023	REAR 29" 32H	DT SWISS 350 HYBRID CLASSIC 32H up to MY2023	SPOKE + SPOKE NIPPLES KIT MC32LTD POWER REAR 32H V1	Sapim E-Light. Butted 14G (2mm).J-Bend. 292mm. Black	2	XC31
				Sapim E-Light. Butted 14G (2 mm). J-Bend. 294 mm. Black	2	
				Sapim Brass Polyax 2 x 14 mm. Black	4	
MC32 LTD POWER from MY2024	FRONT 29" 28H	DT SWISS 350 HYBRID CLASSIC 28H from MY2024	SPOKE + SPOKE NIPPLES KIT MC32LTD POWER FRONT 28H V2	Sapim E-Light. Butted 14G (2mm).J-Bend. 298 mm. Black	2	XD49
				Sapim E-Light. Butted 14G (2 mm). J-Bend. 299 mm. Black	2	
				Sapim Brass Polyax 2 x 14 mm. Black	4	
	REAR 29" 32H	DT SWISS 350 HYBRID CLASSIC 32H from MY2024	SPOKE + SPOKE NIPPLES KIT MC32LTD POWER REAR 32H V2	Sapim E-Light. Butted 14G (2mm).J-Bend. 292 mm. Black	2	XD50
				Sapim E-Light. Butted 14G (2 mm). J-Bend. 291 mm. Black	2	
				Sapim Brass Polyax 2 x 14 mm. Black	4	
MC32 TEAM POWER V1 up to MY2023	FRONT 29" 32H	DT SWISS 350 HYBRID CLASSIC 32H up to MY2023	SPOKE + SPOKE NIPPLES KIT MC32TEAM POWER FRONT 32H V1	Sapim E-Light. Butted. 14G (2mm).J-Bend. 292 mm. Black	2	XC45
				Sapim E-Light. Butted. 14G (2 mm). J-Bend. 294 m. Black	2	
				Sapim Brass Polyax 2 x 14 mm. Black	4	
	REAR 29" 32H	DT SWISS 350 HYBRID CLASSIC 32H up to MY2023	SPOKE + SPOKE NIPPLES KIT MC32TEAM POWER REAR 32H V1	Sapim E-Light. Butted. 14G (2mm).J-Bend. 291 mm. Black	2	XC49
				Sapim E-Light. Butted. 14G (2 mm). J-Bend. 293 mm. Black	2	
				Sapim Brass Polyax 2 x 14 mm. Black	4	
MC32 TEAM POWER V2 MY2024	FRONT 29" 28H	DT SWISS 350 HYBRID CLASSIC 28H from MY2024	SPOKE + SPOKE NIPPLES KIT MC32TEAM POWER FRONT 28H V2	Sapim E-Light. Butted. 14G (2mm).J-Bend. 297m. Black	2	XD51
				Sapim E-Light. Butted. 14G (2mm).J-Bend. 298m. Black	2	
				Sapim Brass Polyax 2 x 14 mm. Black	4	
	REAR 29" 32H	DT SWISS 350 HYBRID CLASSIC 32H from MY2024	SPOKE + SPOKE NIPPLES KIT MC32TEAM POWER REAR 29 32H V2	Sapim E-Light. Butted. 14G (2mm).J-Bend. 291 mm. Black	2	XD52
				Sapim E-Light. Butted. 14G (2mm).J-Bend. 292mm. Black	2	
				Sapim Brass Polyax 2 x 14 mm. Black	4	
	REAR 27.5" 32H	DT SWISS 350 HYBRID CLASSIC 32H from MY2024	SPOKE + SPOKE NIPPLES KIT MC32TEAM POWER REAR 27.5 32H V2	Sapim E-Light. Butted. 14G (2mm).J-Bend. 271 mm. Black	4	XD54
				Sapim Brass Polyax 2 x 14 mm. Black	4	
MC32 TEAM POWER V3 MY2025	FRONT 29" 28H	DT SWISS 350 HYBRID CLASSIC 28H from MY2024	SPOKE + SPOKE NIPPLES KIT MC32 TEAM POWER FRONT 28H V3-V4	Sapim E-Light. Butted. 14G (2mm).J-Bend. 301mm. Black	2	XH71
				Sapim E-Light. Butted. 14G (2mm).J-Bend. 300mm. Black	2	
				Oquo anodised nipples 2 x 18 mm. + washers	4	
	REAR 29" 32H	DT SWISS 350 HYBRID CLASSIC 32H from MY2024	SPOKE + SPOKE NIPPLES KIT MC32 TEAM POWER REAR 29 32H V3-V4	Sapim E-Light. Butted. 14G (2mm).J-Bend. 294 mm. Black	2	XH72
				Sapim E-Light. Butted. 14G (2mm).J-Bend. 295mm. Black	2	
				Oquo anodised nipples 2 x 18 mm. + washers	4	
	REAR 27.5" 32H	DT SWISS 350 HYBRID CLASSIC 32H from MY2024	SPOKE + SPOKE NIPPLES KIT MC32 TEAM POWER REAR 27.5 32H V3-V4	Sapim E-Light. Butted. 14G (2mm).J-Bend. 276 mm. Black	2	XH73
				Sapim E-Light. Butted. 14G (2mm).J-Bend. 275 mm. Black	2	
				Oquo anodised nipples 2 x 18 mm. + washers	4	

Click on the part number to buy online.

**SPOKES. OQUO WHEEL SPOKE KITS****MOUNTAIN CONTROL (MC) POWER**

WHEEL MODEL	FRONT / REAR	HUB	DESCRIPTION SPARE PART	INCLUDES	QUANT.	CODE ART. ORBEA
<b>MC32 TEAM POWER V4</b> from MY2026	FRONT 29" 28H	DT SWISS 350 HYBRID CLASSIC 28H from MY2024	SPOKE + SPOKE NIPPLES KIT MC32 TEAM POWER FRONT 28H V3-V4	Sapim E-Light. Butted. 14G (2mm).J-Bend. 301mm. Black	2	XH71
				Sapim E-Light. Butted. 14G (2mm).J-Bend. 300mm. Black	2	
				Oquo anodised nipples 2 x 18 mm. + washers	4	
	REAR 29" 32H	DT SWISS 350 HYBRID CLASSIC 32H from MY2024	SPOKE + SPOKE NIPPLES KIT MC32 TEAM POWER REAR 29 32H V3-V4	Sapim E-Light. Butted. 14G (2mm).J-Bend. 294 mm. Black	2	XH72
				Sapim E-Light. Butted. 14G (2mm).J-Bend. 295mm. Black	2	
				Oquo anodised nipples 2 x 18 mm. + washers	4	
	REAR 27.5" 32H	DT SWISS 350 HYBRID CLASSIC 32H from MY2024	SPOKE + SPOKE NIPPLES KIT MC32 TEAM POWER REAR 27.5 32H V3-V4	Sapim E-Light. Butted. 14G (2mm).J-Bend. 276 mm. Black	2	XH73
				Sapim E-Light. Butted. 14G (2mm).J-Bend. 275 mm. Black	2	
				Oquo anodised nipples 2 x 18 mm. + washers	4	

Click on the part number to buy online.

## OQUO TUBELESS VALVES

### Tubeless valve installation on asymmetric rims

On some OQUO rims with asymmetrical profile it is necessary to use the asymmetrical adapter between the rim and the valve nut so that the valve assembly seats correctly on the outside of the rim.

The adapter is included with OQUO wheels with asymmetrical profile that require it.

See the valve length table in the following section to find out which OQUO wheel models require the installation of the asymmetric valve adapter.

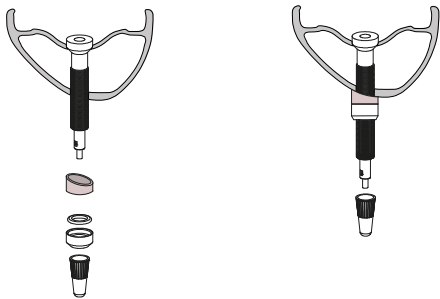

### Tubeless valve length

See the table below for the length of the Tubeless valve used on your OQUO wheels

FAMILY	WHEEL MODEL	VALVE LENGTH		ASYMMETRIC VALVE ADAPTER
		Front	Rear	
MOUNTAIN PERFORMANCE	MP30LTD	44 mm	44 mm	NO
	MP30TEAM	44 mm	44 mm	NO
	MP28PRO	40 mm	40 mm	YES <a href="#">XB66</a>
MOUNTAIN CONTROL	MC32LTD	44 mm	44 mm	NO
	MC32LTD POWER	44 mm	44 mm 57 mm on Wild with valve magnet	NO
	MC32TEAM V1 (up to MY2024)	44 mm	44 mm	YES <a href="#">XB66</a>
	MC32TEAM V2-V3 (from MY2025)	44 mm	44 mm	YES <a href="#">XH67</a>
	MC32 TEAM RALLON DH (from MY2026)	44 mm	44 mm	YES <a href="#">XH67</a>
	MC32 TEAM POWER V1 (up to MY2023)	44 mm	44 mm 57 mm on Wild with valve magnet	YES <a href="#">XB66</a>
	MC32 TEAM POWER V2-V4 (from MY2024)	44 mm	44 mm 57 mm on Wild with valve magnet	YES <a href="#">XH67</a>

[Click on the part number to buy online.](#)

### Tool integrated in the OQUO valve cap

OQUO Tubeless valves have a tool for removing the Tubeless valve core integrated into the valve cap.

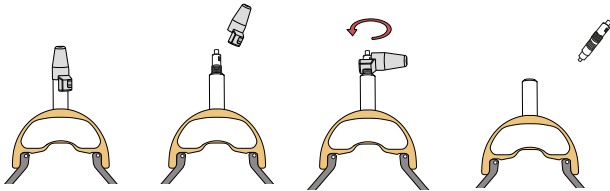

### OQUO accessories

ITEM No.	DESCRIPTION	QUAN-T.	
X803	<b>OQUO TUBELESS VALVE KIT 44mm</b> With plug valve core tool	2	
X804	<b>OQUO TUBELESS VALVE KIT 44mm + 57mm</b> With plug valve core tool Does not include adapter for asymmetric rims		
XB67	<b>OQUO TUBELESS VALVE PLUG KIT</b> Built-in valve core tool	2	
XB66	<b>ASYMMETRIC RIM VALVE ADAPTER KIT V1</b> Check the table in the previous section to see if your Oquo wheels need an adapter	2	
XH67	<b>ASYMMETRIC RIM VALVE ADAPTER KIT V2</b> Check the table in the previous section to see if your Oquo wheels need an adapter	2	
XH28	<b>OQUO VALVE CLOSURE KIT</b>	10	

Click on the part number to buy online.

---

## OQUO WHEEL CONSTRUCTION



---

This section gives general spoke lacing and finishing instructions for OQUO wheels for OQUO dealers who must replace an OQUO rim after approval by OQUO, and is not intended as a bicycle wheel construction manual.

The correct and safe construction of wheels requires extensive technical knowledge and experience. Users or technicians who have not received the necessary training or do not have the necessary experience should not build a bicycle wheel for subsequent use.



---

Incorrect wheel construction can compromise the structural integrity and durability of the wheel and can lead to component failure that is not covered by the warranty conditions and can result in serious injury or death.

### TOOLS

Please refer to the OQUO Wheel Maintenance section, which describes the tools required for the correct maintenance and construction of OQUO wheels.

Always use the right tools and products for wheel construction. Unsuitable or poorly maintained tools, or the use of generic products, may cause damage to components that are not then covered by the warranty conditions.

## ASYMMETRIC RIMS

If the rim has an asymmetric profile (refer to the specification table in this manual to find out if a model uses an asymmetric rim), always orient the rim according to the instructions below.

- **Front rims**

The rim offset must be oriented towards the drive side

- **Rear rims**

The rim offset must be oriented towards the non-drive side.

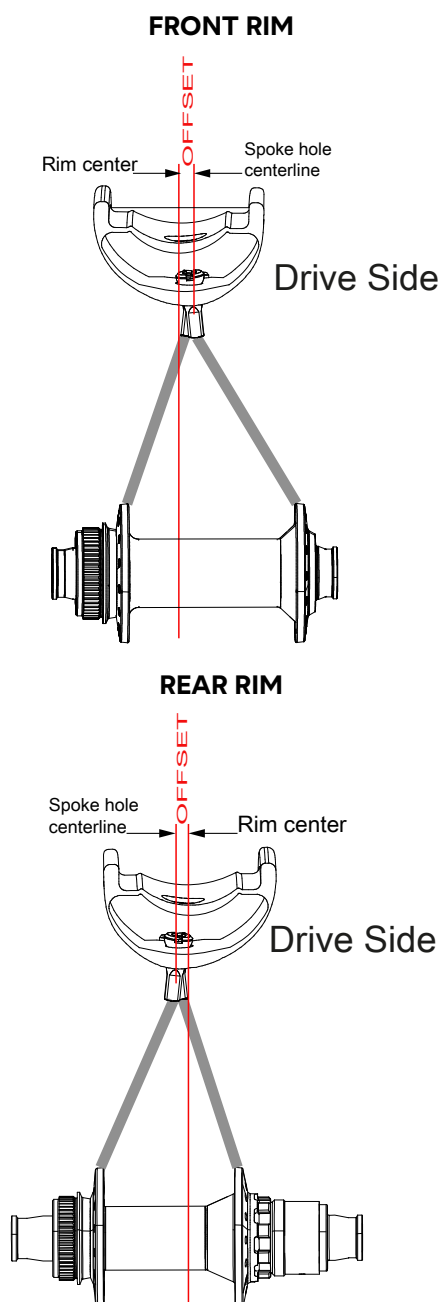

## SYMMETRIC RIMS

In the case of symmetrical rims (no offset), orient the rim so that any decals or stickers are readable from the same side of the bike as they were on the original wheel.

## DIRECTIONAL SPOKE HOLES

If the rim has directional spoke holes, always build the wheel so that the orientation of the holes in the rim matches the corresponding hub side.

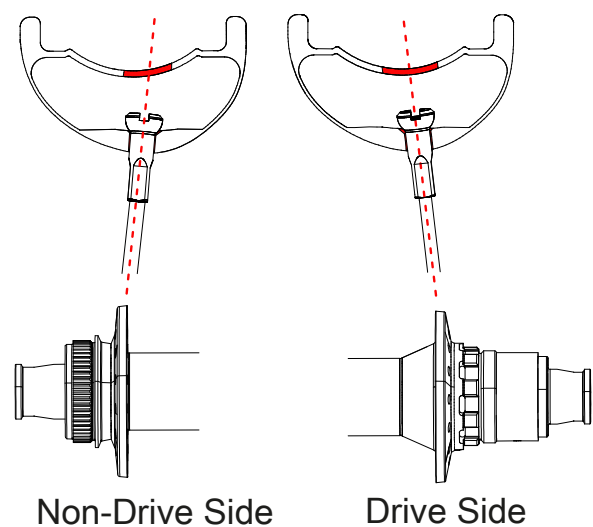

## SPECIFIC FRONT AND REAR WHEEL RIMS

On OQUO models with a specific front or rear wheel rim, be sure to use the specific rim designed for that wheel.

In the technical specification table of this manual you can check whether your model uses specific front and rear wheel rims.

Rims specifically for front wheels include the letter F in the rim model name.

Rims specifically for rear wheels include the letter R in the rim model name.

Rims which are not specifically for front or rear wheels include the letter B in the rim model name.

## SPOKES AND NIPPLES

Always use the spoke and nipple models specified by OQUO for the model of wheel.

You can check the components of each model in the technical specifications table in this manual.

### CLASSIC OR T-SHAPE STRAIGHTPULL SPOKES

Either classic or T-Shape straightpull spokes must be mounted depending on the spoke head housing on a straightpull hub.

On T-Shape straightpull spoke hubs, the spoke head housing is rectangular such as to enclose the spoke head and prevent it from twisting or loosening.

On classic straightpull spoke hubs, the spoke head housing is round, so the spokes must have a standard head.

### T-SHAPE STRAIGHTPULL SPOKES



### NIPPLES WITH REINFORCING WASHERS

Some nipples use reinforcing washers installed between the nipple and rim wall.

Check your wheel specification table to see whether reinforcement washers need to be installed.

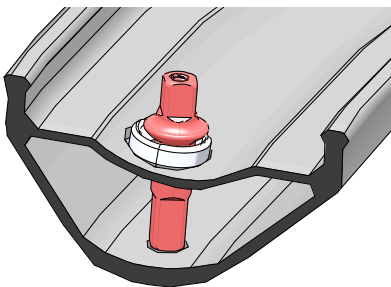

## J-BEND SPOKE PATTERNS



Unlike in assemblies with J-bend spokes, in assemblies with straightpull spokes the spoke pattern is predefined by the hub and cannot be chosen when assembling the wheel.

Always mount the wheel following the original spoke pattern for each side of the wheel.

Make sure that the spokes cross each other correctly (above or below).

### 3 CROSS

Each spoke crosses three other spokes on the same side of the wheel before being fastened to the rim.

Depending on which side of the hub flange the spoke exits from, there are two possible positions for it relative to the other three spokes.

If the spoke exits from the outer side of the hub flange, the position with respect to the spokes which it crosses must be:

- 01** Over
- 02** Over
- 03** Under

If the spoke exits from the inner side of the hub flange, the position with respect to the spokes which it crosses must be:

- 01** Under
- 02** Under
- 03** Over

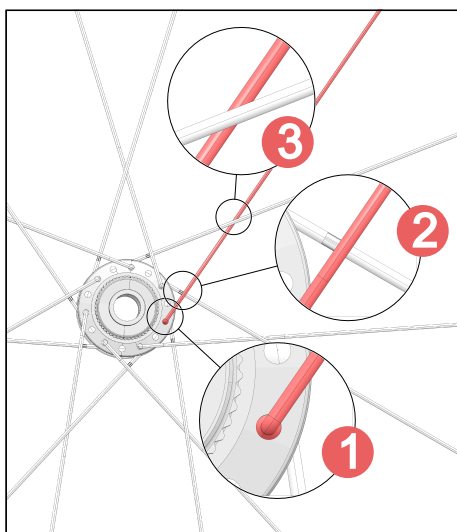

### 2 CROSS

Each spoke crosses two other spokes on the same side of the wheel before being fastened to the rim.

Depending on which side of the hub flange the spoke exits from, there are two possible positions for it relative to the other two spokes.

If the spoke exits from the outer side of the hub flange, the position with respect to the spokes which it crosses must be:

- 01** Over
- 02** Under

If the spoke exits from the inner side of the hub flange, the position with respect to the spokes which it crosses must be:

- 01** Under
- 02** Over

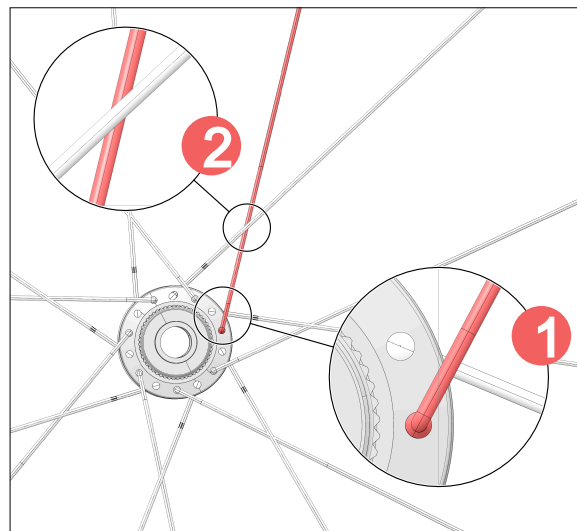

**POSITION OF "LEADING" AND "TRAILING" J-BEND SPOKES**



In assemblies with straightpull hub and spokes, the position of the spokes and hub is one-way and cannot be chosen when assembling the wheel.

Check the position of the "leading" and "trailing" spokes in the specification table in this manual, or on the original wheel, and spoke the wheel in the same way for each side of the wheel.

**"Trailing" spoke**

Spokes coming out of the hub in the direction opposite to the direction of rotation of the wheel.

**"Leading" spoke**

Spokes coming out of the hub in the same direction as the direction of rotation of the wheel.

The following images are examples of spoke patterns. Check the original wheel spoke pattern or the spoke pattern in the specification table.



Direction of wheel rotation

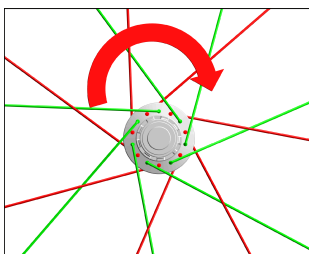

REAR WHEEL DRIVE SIDE

**Trailing:** Outside the hub flange  
**Leading:** Inside the hub flange

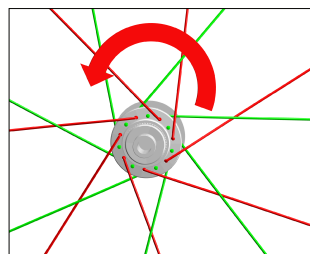

REAR WHEEL NON-DRIVE SIDE

**Trailing:** Inside the hub flange  
**Leading:** Outside the hub flange

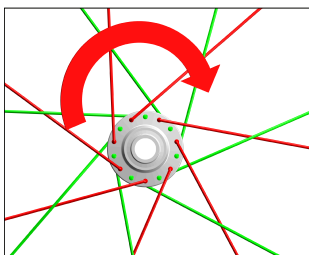

FRONT WHEEL DRIVE SIDE

**Trailing:** Inside the hub flange  
**Leading:** Outside the hub flange

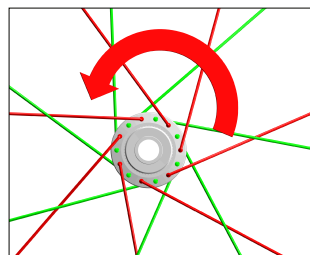

FRONT WHEEL NON-DRIVE SIDE

**Trailing:** Inside the hub flange  
**Leading:** Outside the hub flange

**POSITION OF THE VALVE HOLE**

The valve hole in the rim should be positioned between two parallel spokes to facilitate tyre inflation.

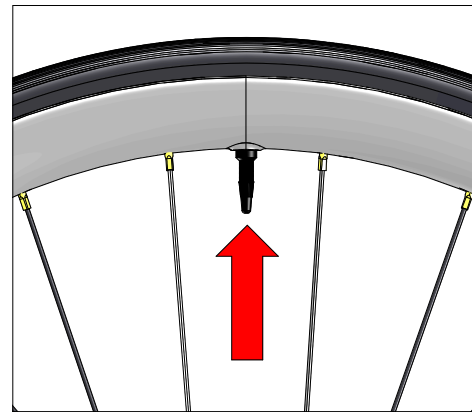

**POSITION OF THE HUB LOGO**

For aesthetic reasons, if the hub has a logo on the hub body, the position of the hub relative to the rim should allow the hub logo to be aligned with the rim valve hole.

This point has no effect on the function of the wheel, so assemblies that do not meet this condition are considered valid for all purposes as long as all other assembly parameters are correct.

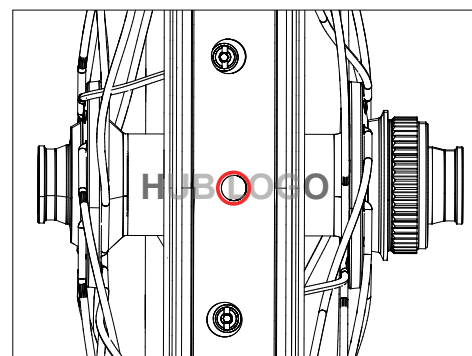

## PROCESS OF TENSIONING AND TRUING.

The correct and safe construction of wheels requires extensive technical knowledge and experience. Users or technicians who have not received the necessary training or do not have the necessary experience should not build a bicycle wheel for subsequent use.



This manual does not include full instructions on the complete lacing and tensioning process of bicycle wheels, but general guidelines on OQUO wheel finishing and allowable tolerances. It is only a guide to general lacing and finishing instructions for OQUO wheels for OQUO dealers who must replace an OQUO rim after approval by OQUO, and is not intended as a bicycle wheel construction manual.



Incorrect wheel construction may compromise the structural integrity and durability of the wheel and could be the cause of component failure not covered by the warranty conditions, which could result in serious injury or death.

Once the wheel has been spoked and the nipples installed without adding tension to the wheel, proceed with truing the wheel to the tolerance specifications described in this manual. Add tension to the wheel gradually and evenly. Perform the following checks after adjusting a few spokes.

OQUO recommends that the wheel alignment check process be:

- 01** Check the lateral alignment
- 02** Check the radial truing
- 03** Check the lateral truing on both sides of the wheel.

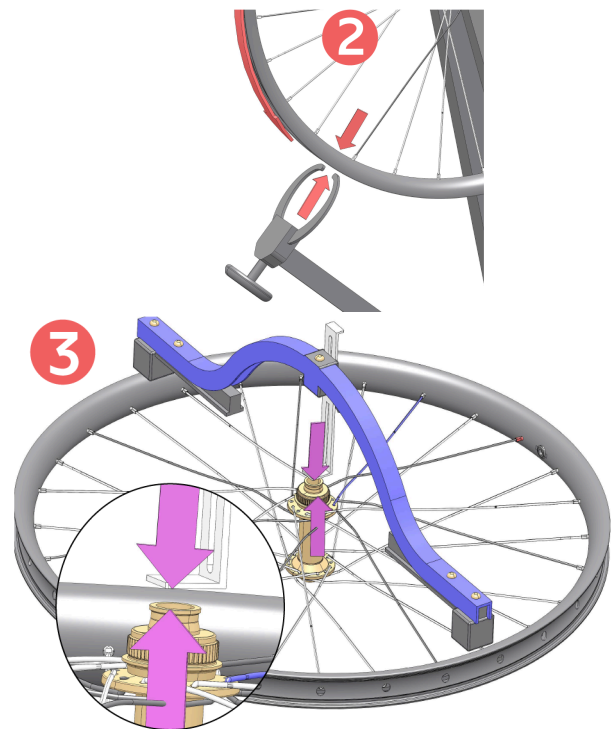
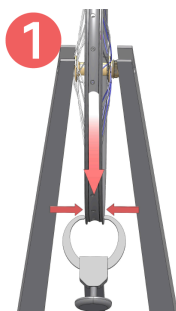

Repeat these checks as many times as necessary during the spoke tensioning process whenever you add tension to several spokes to avoid excessive run-outs that can damage the rim.

### NOTICE

After each lateral, radial and dishing alignment check, de-stress the wheel to allow the spokes to settle into position and the checks to be true.

You can de-stress the wheel by resting one end of the hub on a solid surface and pushing opposite sides of the rim in the direction the hub is resting with your hands, putting your own weight on your hands.

Make this check on both sides of the wheel.

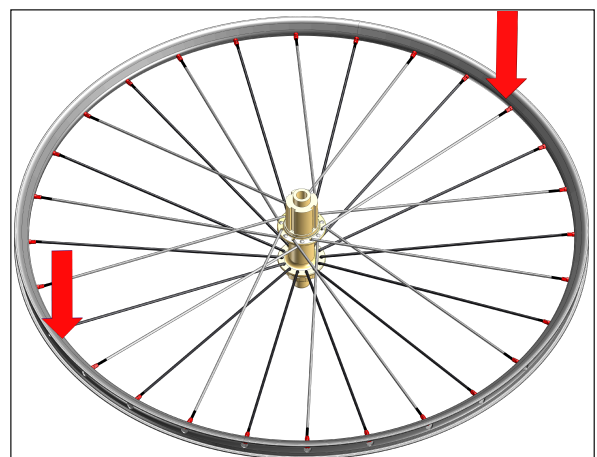

### CHECKING THE SPOKE TENSION

See the target tension on the tightest side of each wheel for your model in the Technical Specification Table in this manual (Spokes section). Once the target tension on the specified side of the wheel has been reached, and the lateral, radial, and dishing run-out values are within the specified tolerances, the tension of the spokes on the less stressed side must be uniform.

Always use a quality tension meter and regularly check its calibration according to the manufacturer's instructions.

Follow the manufacturer's instructions for proper use and to properly interpret the tension reading depending on the specifications of the spokes.

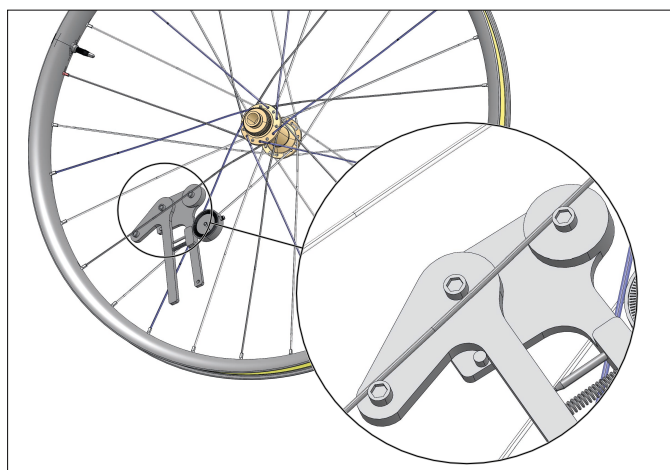

## ASSEMBLY COMPOUND

If you are carrying out maintenance or lacing up on one of our wheels, once the wheel is correctly trued and tensioned, we recommend the use of a medium strength spoke thread-locking compound that is as fluid as possible on the spoke threads.

## OQUO WHEEL ASSEMBLY INSTRUCTIONS AND TOLERANCES

OQUO WHEEL TARGET ASSEMBLY TENSION	
TENSION	<p><b>Check the target tension of the tightest side of each wheel for your model in the Technical Specifications Table of this manual (Spokes section)</b></p> <p>Once the target tension on the specified side of the wheel has been reached, and the lateral, radial, and dishing runout values are within the specified tolerances, the tension of the spokes on the less stressed side must be uniform.</p>
	<p><b>AVERAGE TENSION TOLERANCE OF THE SPOKES ON THE TIGHTER SIDE OF THE WHEEL</b></p>
	<p>+/- 5%</p>

Always use a quality tension meter and regularly check its calibration according to the manufacturer's instructions. Follow the manufacturer's instructions for proper use and to properly interpret the tension reading depending on the specifications of the spokes.

RUNOUT		LATERAL	RADIAL	DISHING
	Aluminium	0.4 mm	0.6mm	0.6mm
Carbon	0.3mm	0.6mm	0.3mm	

---

## ADDITIONAL INFORMATION

Find more information about OQUO in social media

### FACEBOOK

[www.facebook.com/oquo.wheels](http://www.facebook.com/oquo.wheels)

### INSTAGRAM

[www.instagram.com/oquo.wheels/](http://www.instagram.com/oquo.wheels/)

### LINKEDIN

[www.linkedin.com/company/oquowheels/](http://www.linkedin.com/company/oquowheels/)

### YOUTUBE

[www.youtube.com/channel/UCpXzSOB\\_9oLzLzAnnwuaGCg](http://www.youtube.com/channel/UCpXzSOB_9oLzLzAnnwuaGCg)

### MANUALS

Download the latest version of this manual, as well as any other OQUO products at:

[www.oquowheels.com/en-int/support/manuals](http://www.oquowheels.com/en-int/support/manuals)

### CONTACT

If you have any questions about our products, please visit:

[www.oquowheels.com/en-int/support/contact](http://www.oquowheels.com/en-int/support/contact)

---

**Orbea OQUO SL 2025**  
**Polígono Industrial Kareaga, 2. NAV 49,**  
**Markina-Xemein. 48270. Bizkaia**  
**T. 0034 943 171 950**

All rights reserved. Modification of this document is forbidden.

This technical manual on the product is for informational purposes only regarding the assembly, installation and maintenance of said product, and as such may be subject to changes in specifications and/or future updates of said information by the manufacturer. Its content has no advertising or contractual value in relation to the product described, and its content should not be considered by the user as an element of advice regarding their decision to purchase the product. Therefore, we do not assume any responsibility to the user or third party if this Manual is used for a purpose other than that intended and specified within.

All rights reserved. Modification of this document is forbidden. The contents of this manual are subject to specification changes without prior notice.

For the latest version, please visit: [www.oquowheels.com](http://www.oquowheels.com)

---

## ÍNDICE

<b>Introducción</b>	<b>69</b>
<b>Tipos de manuales</b>	<b>70</b>
<b>Leyenda de símbolos</b>	<b>71</b>
<b>Advertencias generales del manual técnico</b>	<b>72</b>
<b>Especificaciones técnicas y de montaje de ruedas Oquo</b>	<b>73</b>
Mapa de gama ruedas Oquo MTB	73
Mountain Performance (MP)	74
MP30 LTD (hasta MY2024)	74
MP30 LTD (desde MY2025)	75
MP30 TEAM (hasta MY2024)	76
MP30 TEAM (desde MY2025)	77
MP28 PRO (hasta MY2023)	78
MP28 PRO (desde MY2024)	79
Mountain Control (MC)	80
MC32 LTD (hasta MY2025)	80
MC32 LTD (desde MY2026)	81
MC32 LTD POWER (hasta MY2023)	82
MC32 LTD POWER (desde MY2024)	83
MC32 TEAM (hasta MY2024)	84
MC32 TEAM (MY2025)	85
MC32 TEAM (desde MY2026)	86
MC32 TEAM RALLON DH MY2026 (OEM)	87
MC32 TEAM POWER (hasta MY2023)	88
MC32 TEAM POWER (MY2024)	89
MC32 TEAM POWER (MY2025)	90
MC32 TEAM POWER (desde MY2026)	91
<b>Mantenimiento de ruedas Oquo</b>	<b>92</b>
Tabla de periodos de mantenimiento	92
Herramientas	92
<b>Mantenimiento de bujes</b>	<b>98</b>
<b>Recambios</b>	<b>100</b>
Recambios de bujes OQUO DT Swiss Inside	100
Bujes delanteros Oquo DT Swiss Inside	100
Oquo LTD DT Swiss 240 Inside Straight Pull 15x110 24H Centerlock	100

Oquo TEAM DT Swiss 350 Inside Straight Pull 15x110 28H Centerlock/6-bolt	101
Oquo LTD DT Swiss 350 Inside J-bend 15x110 28H 6-bolt	102
Bujes traseros Oquo DT Swiss Inside	103
Oquo LTD DT Swiss 240 Inside Straight Pull 12x148 28H Centerlock	103
Oquo LTD DT Swiss 350 Inside Straight Pull 12x148 28/32H Centerlock/6-bolt	104
Oquo LTD DT Swiss Inside 350 DEG J-bend 12x148 32H 6-bolt	105
Recambios de bujes DT Swiss	106
Bujes delanteros DT Swiss	106
DT Swiss 240 J-bend 15x110 24/28H Centerlock/6-bolt	106
DT Swiss 350 J-bend 15x110 28H Centerlock/6-bolt	107
DT Swiss 350 J-bend 20x110 28H 6-bolt	108
DT Swiss 370 J-bend 15x110 28H 6-bolt	109
DT Swiss 350 Hybrid J-bend 15x110 32H 6-bolt (hasta MY2023)	110
DT Swiss 350 Hybrid J-bend 15x110 28H 6-bolt (desde MY2024)	111
Bujes traseros DT Swiss	112
DT Swiss 240 J-bend 12x148 28H Centerlock	112
DT Swiss 350 J-bend 12x148 28/32H Centerlock/6-bolt	113
DT Swiss 370 J-bend 12x148 28H 6-bolt	114
DT Swiss 350 Hybrid J-bend 12x148 32H 6-bolt (hasta MY2023)	115
DT Swiss 350 Hybrid J-bend 12x148 32H 6-bolt (desde MY2024)	116
Radios. Kits de radios ruedas Oquo	117
Válvulas tubeless Oquo	121
<b>Construcción de ruedas Oquo</b>	<b>123</b>
<b>Información Adicional</b>	<b>131</b>

---

## INTRODUCCIÓN

La información contenida en este manual está principalmente dirigida a distribuidores OQUO y usuarios con cierta experiencia en el mantenimiento de ruedas.

Si, como usuario, no dispones del conocimiento para llevar a cabo los procesos de mantenimiento descritos en este manual técnico o instalar los repuestos listados, lleva tus ruedas a un distribuidor OQUO para su reparación o mantenimiento.

Puedes encontrar la información de contacto de nuestros distribuidores en nuestra web:

[www.oquowheels.com](http://www.oquowheels.com)

### AVISO

---

Daños producidos por llevar a cabo los procesos de mantenimiento o reparaciones de manera inadecuada no están cubiertos por las condiciones de garantía.



La instalación de componentes, reparaciones o mantenimientos realizados de manera inadecuada pueden afectar a la integridad y funcionamiento de las ruedas, pudiendo ser causa de accidentes y lesiones graves, incluso la muerte.

---

## TIPOS DE MANUALES

### MANUAL TÉCNICO

Este manual detalla las especificaciones, los procesos de mantenimiento y los recambios originales de productos OQUO para distribuidores especializados o usuarios con las habilidades necesarias.

Los procesos de mantenimiento de componentes de otros fabricantes en nuestras ruedas se encuentran referenciados a través de los enlaces a la documentación del propio fabricante.

Los procesos, especificaciones y recambios descritos en este manual están sujetos a cambios de especificaciones de nuestros productos.

Puedes consultar la versión más actualizada de este manual técnico en la web de OQUO.

### MANUAL DE USUARIO

Para acceder al manual de usuario de nuestras ruedas, que detalla información sobre el uso correcto, advertencias de uso, transporte y almacenamiento, instalación, etc. de las mismas, consulta el manual de usuario en nuestra web.

Puedes acceder a toda la documentación de nuestros productos, así como la información relevante de garantía y programas de servicio en nuestra web:

[www.oquowheels.com/es-es/soporte/manuales](http://www.oquowheels.com/es-es/soporte/manuales)

---

## LEYENDA DE SÍMBOLOS

A lo largo de este manual se utilizan varios símbolos que detallan instrucciones, advertencias o información relevante de uso, mantenimiento y montaje. Presta atención a estos símbolos para evitar situaciones peligrosas y asegurar el uso y montaje correcto de todos los componentes.

El significado de estos símbolos se explica a continuación. En este manual, puede que el símbolo aparezca acompañado únicamente de la instrucción relevante para el componente que describe. Lee la siguiente información con atención para entender su significado.

### INSTRUCCIONES DE SEGURIDAD



---

**PELIGRO:** Situación peligrosa que, si no se evita, provocará lesiones graves o incluso la muerte



---

**ADVERTENCIA:** Situación peligrosa que, si no se evita, puede causar lesiones graves o incluso la muerte.



---

**ATENCIÓN:** Situación peligrosa que, de no evitarse, podría provocar lesiones leves o moderadas.

#### AVISO

---

Situación no relacionada con lesiones físicas. Información relevante.

Los símbolos PELIGRO y ADVERTENCIA siempre implican un riesgo de accidente si no se toman medidas para evitar la situación que describen. Un accidente circulando con una bicicleta siempre puede conllevar riesgo de lesiones graves o incluso de muerte. En este manual no siempre se repetirá el riesgo de muerte cuando aparezcan estos símbolos, ya que el riesgo se detalla en este punto.

### HERRAMIENTAS

Utiliza siempre las herramientas y productos adecuados para un mantenimiento o reparación concretos. Herramientas inadecuadas o en mal estado, o el uso de productos no específicos, pueden causar daños en los componentes que no están cubiertos por las condiciones de garantía.

En este manual se especifican las herramientas a utilizar, o se referencian los manuales de mantenimiento de fabricantes de otros componentes en nuestras ruedas, donde se detallan las herramientas apropiadas.

---

## ADVERTENCIAS GENERALES DEL MANUAL TÉCNICO

- Consulta las instrucciones de instalación, mantenimiento y advertencias de uso de componentes de otros fabricantes en nuestras ruedas, como discos de freno, cassettes, cubiertas, etc. en la documentación del fabricante del componente.
- Mantén cualquier parte del cuerpo y/o ropa alejados de los discos de freno o radios durante su uso o ajuste para evitar lesiones y cortes graves.
- Como regla general, limpia todos los componentes durante su mantenimiento o servicio antes de volver a instalarlos.
- Mantén las ruedas y sus componentes limpios y libres de objetos extraños para asegurar su correcto funcionamiento y poder evaluar el estado de los mismos.
- Siempre utiliza un trapo suave y productos de limpieza específicos para limpiar tus ruedas y componentes.
- No uses agua a presión o productos químicos agresivos para la limpieza de las ruedas y sus componentes. El agua a presión puede diluir los lubricantes, acortando la vida útil de los mismos y/o provocando daños no cubiertos por las condiciones de garantía.

### RECAMBIOS

Utiliza sólo recambios originales OQUO o los referenciados en este manual o en la documentación del fabricante del componente.

#### AVISO

---

El uso de recambios no originales puede producir daños en los componentes no cubiertos por las condiciones de garantía.



---

El uso de recambios no originales puede ser causa de fallo de los componentes, pudiendo causar accidentes y lesiones graves.

## ESPECIFICACIONES TÉCNICAS Y DE MONTAJE DE RUEDAS OQUO

En las siguientes tablas se detallan las especificaciones de componentes y montaje de todos los modelos OQUO MTB.

A lo largo de este manual se referencian datos en estas tablas relevantes para secciones específicas, consulta estas tablas para encontrar el dato que buscas.

### MAPA DE GAMA RUEDAS OQUO MTB

	FAMILIA	MODELO	MODALIDAD
MTB	MOUNTAIN PERFORMANCE (MP)	MP30LTD	XC, MARATHON, TRAIL
		MP30TEAM	
		MP28PRO	
	MOUNTAIN CONTROL (MC)	MC32LTD	TRAIL, ENDURO, GRAVITY
		MC32LTD POWER	E-ENDURO, GRAVITY
		MC32TEAM	TRAIL, ENDURO, GRAVITY
		MC32TEAM POWER	E-ENDURO, GRAVITY

## MOUNTAIN PERFORMANCE (MP)

## MP30 LTD (hasta MY2024)

	MODELO	MATERIAL	TALLA	TIPO LLANTA	TIPO FRENO	TUBELESS	ANCHO INTERNO	OFFSET	AGUJEROS DIRECCIONALES	AGUJEROS RADIOS	ERD	ETRTO	UNIÓN	ANCHO CINTA TUBELESS	VÁLVULA	CUBIERTAS COMPATIBLES	PRESIÓN MÁXIMA	SECCIÓN	
LLANTAS	LLANTA DELANTERA (28H)	MP10-F-29-28H	Carbon	29"	Clincher Hookless	Disco	SI	30 mm	2 mm	SI	28	611 mm	622x30TSS	—	30 mm	44 mm	2.05"-2.8"	**	
	LLANTA DELANTERA (24H)	MP11-F-29-24H	Carbon	29"	Clincher Hookless	Disco	SI	30 mm	2 mm	SI	24	611 mm	622x30TSS	—	30 mm	44 mm	2.05"-2.8"	**	
	LLANTA TRASERA	MP10-R-29-28H	Carbon	29"	Clincher Hookless	Disco	SI	30 mm	-2 mm	SI	28	607.6 mm	622x30TSS	—	30 mm	44 mm	2.05"-2.8"	**	

	Nº RADIOS	MODELO	RADIADO DRIVE SIDE	RADIADO NON-DRIVE SIDE	LONGITUD RADIOS DRIVE SIDE	LONGITUD RADIOS NON-DRIVE SIDE	TENSIÓN MONTAJE DRIVE SIDE	TENSIÓN MONTAJE DISC SIDE	LEADING SPOKE DRIVE SIDE	TRAILING SPOKE DRIVE SIDE	LEADING SPOKE NON-DRIVE SIDE	TRAILING SPOKE NON-DRIVE SIDE	
RADIOS	DELANTERA (28H)	28	Sapim CX-Ray TCS Aero 14G (2 mm) J-Bend	3 Cruces	3 Cruces	299 mm	297 mm	—	1200 N	Por fuera	Por dentro	Por fuera	Por dentro
	DELANTERA (24H)	24	Sapim CX-Ray TCS Aero 14G (2 mm) J-Bend	3 Cruces	3 Cruces	293 mm	291 mm	—	1200 N	Por fuera	Por dentro	Por fuera	Por dentro
	TRASERA	28	Sapim CX-Ray TCS Aero 14G (2 mm) J-Bend	3 Cruces	3 Cruces	295 mm	296 mm	1300 N	—	Por dentro	Por fuera	Por fuera	Por dentro

	MODELO	SPACING (OLD)	EJE	TIPO DISCO	RADIOS	NÚCLEO	MECANISMO NÚCLEO
BUJES	BUJE DELANTERO (28H)	DT SWISS 240 Classic CL	Boost 110 mm	Pasante 15 mm	Center Lock	28 J-Bend	—
	BUJE DELANTERO (24H)	DT SWISS 240 Classic CL	Boost 110 mm	Pasante 15 mm	Center Lock	24 J-Bend	—
	BUJE TRASERO	DT SWISS 240 Classic CL	Boost 148 mm	Pasante 12 mm	Center Lock	28 J-Bend	Sram XD or Shimano Microspline Ratchet EXP 36

	MODELO	MEDIDAS	ARANDELA CABECILLAS	
CABECILLAS	DELANTERA (28H)	Sapim Alloy Double Square	2x18 mm (14G)	No
	DELANTERA (24H)	Sapim Alloy Double Square	2x18 mm (14G)	No
	TRASERA	Sapim Alloy Double Square	2x18 mm (14G)	No

	RUEDA	PESO
PESO RUEDA	DELANTERA (28H)	625gr +/-5%
	DELANTERA (24H)	591gr +/-5%
	TRASERA	730gr +/-5%

USO.
<p><b>ASTM Condición 3</b> (Ver manual de usuario)</p> <p>Peso máximo del sistema (bicicleta + ciclista + equipación) = <b>110 kg.</b></p>

\*\* Para conocer la presión máxima de la llanta, consulta el manual de usuario o la calca en la propia rueda.

[Pincha en el modelo de buje o radios para acceder a la información de recambios](#)

## MOUNTAIN PERFORMANCE (MP)

## MP30 LTD (desde MY2025)

	MODELO	MATERIAL	TALLA	TIPO LLANTA	TIPO FRENO	TUBELESS	ANCHO INTERNO	OFFSET	AGUJEROS DIRECCIONALES	AGUJEROS RADIOS	ERD	ETRTO	UNIÓN	ANCHO CINTA TUBELESS	VÁLVULA	CUBIERTAS COMPATIBLES	PRESIÓN MÁXIMA	SECCIÓN	
LLANTAS	LLANTA DELANTERA	MP11-F-29-24H	Carbon	29"	Clincher Hookless	Disco	SI	30 mm	2 mm	SI	24	601 mm	622x30TSS	—	30 mm	44 mm	2.05"-2.8"	**	
	LLANTA TRASERA	MP10-R-29-28H	Carbon	29"	Clincher Hookless	Disco	SI	30 mm	-2 mm	SI	28	599 mm	622x30TSS	—	30 mm	44 mm	2.05"-2.8"	**	

	Nº RADIOS	MODELO	RADIADO DRIVE SIDE	RADIADO NON-DRIVE SIDE	LONGITUD RADIOS DRIVE SIDE	LONGITUD RADIOS NON-DRIVE SIDE	TENSIÓN MONTAJE DRIVE SIDE	TENSIÓN MONTAJE DISC SIDE	
RADIOS	DELANTERA (24H)	24	DT aerolite T-shape SP* 2.0-(0.9x2.2)-2mm	2 Cruces	2 Cruces	301 mm	301 mm	—	1200 N
	TRASERA	28	DT aerolite T-shape SP* 2.0-(0.9x2.2)-2mm	3 Cruces	3 Cruces	304 mm	304 mm	1300 N	—

BUJES	MODELO	SPACING (OLD)	EJE	TIPO DISCO	RADIOS	NÚCLEO	MECANISMO NÚCLEO	CABECILLAS	MODELO	MEDIDAS	ARANDELA CABECILLAS	PESO RUEDA	RUEDA	PESO	USO
	BUJE DELANTERO	OQUO LTD DT 240 INSIDE	Boost 110 mm	Pasante 15 mm	Center Lock	24 SP*	—		—	DELANTERA	DT Alloy Double Square		2x15 mm (FG 2,3)	No	
BUJE TRASERO	OQUO LTD DT 240 INSIDE	Boost 148 mm	Pasante 12 mm	Center Lock	28 SP*	Sram XD or SPShimano Microspline	DT Swiss Ratchet EXP 10° / 36	TRASERA	DT Alloy Double Square	2x15 mm (FG 2,3)	No	TRASERA	740gr +/-5%		

\* SP: Straightpull

\*\* Para conocer la presión máxima de la llanta, consulta el manual de usuario o la calca en la propia rueda.

[Pincha en el modelo de buje o radios para acceder a la información de recambios](#)**ASTM Condición 3**  
(Ver manual de usuario)Peso máximo del sistema  
(bicicleta + ciclista +  
equipación) =  
**110 kg.**

## MOUNTAIN PERFORMANCE (MP)

## MP30 TEAM (hasta MY2024)

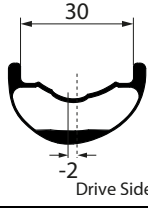
	MODELO	MATERIAL	TALLA	TIPO LLANTA	TIPO FRENO	TUBELESS	ANCHO INTERNO	OFFSET	AGUJEROS DIRECCIONALES	AGUJEROS RADIOS	ERD	ETRTO	UNIÓN	ANCHO CINTA TUBELESS	VÁLVULA	CUBIERTAS COMPATIBLES	PRESIÓN MÁXIMA	SECCIÓN	
LLANTAS	LLANTA DELANTERA	MP10-F-29-28H	Carbon	29"	Clincher Hookless	Disco	SI	30 mm	2 mm	SI	28	611 mm	622x30TSS	—	30 mm	44 mm	2.05"-2.8"	**	
	LLANTA TRASERA	MP10-R-29-28H	Carbon	29"	Clincher Hookless	Disco	SI	30 mm	-2 mm	SI	28	607.6 mm	622x30TSS	—	30 mm	44 mm	2.05"-2.8"	**	

	Nº RADIOS	MODELO	RADIADO DRIVE SIDE	RADIADO NON-DRIVE SIDE	LONGITUD RADIOS DRIVE SIDE	LONGITUD RADIOS NON-DRIVE SIDE	TENSIÓN MONTAJE DRIVE SIDE	TENSIÓN MONTAJE DISC SIDE	LEADING SPOKE DRIVE SIDE	TRAILING SPOKE DRIVE SIDE	LEADING SPOKE NON-DRIVE SIDE	TRAILING SPOKE NON-DRIVE SIDE
DELANTERA	28	Sapim D-Sprint Butted 14G (2 mm) J-Bend	3 Cruces	3 Cruces	298 mm	297 mm	—	1200 N	Por fuera	Por dentro	Por fuera	Por dentro
TRASERA	28	Sapim D-Sprint Butted 14G (2 mm) J-Bend	3 Cruces	3 Cruces	294 mm	295 mm	1300 N	—	Por dentro	Por fuera	Por fuera	Por dentro

BUJES	MODELO	SPACING (OLD)	EJE	TIPO DISCO	RADIOS	NÚCLEO	MECANISMO NÚCLEO	CABECILLAS	MODELO	MEDIDAS	ARANDELA CABECILLAS	PESO RUEDA	PESO	USO
BUJE DELANTERO	DT SWISS 350 Classic CL	Boost 110 mm	Pasante 15 mm	Center Lock	28 J-Bend	—	—	DELANTERA	Sapim Brass Polyax	2x14 mm (14G)	No	DELANTERA	700gr +/-5%	<b>ASTM Condición 3</b> (Ver manual de usuario)  Peso máximo del sistema (bicicleta + ciclista + equipación) = <b>110 kg.</b>
BUJE TRASERO	DT SWISS 350 Classic CL	Boost 148 mm	Pasante 12 mm	Center Lock	28 J-Bend	Sram XD or Shimano Microspline	Ratchet 36	TRASERA	Sapim Brass Polyax	2x14 mm (14G)	No	TRASERA	830gr +/-5%	

\*\* Para conocer la presión máxima de la llanta, consulta el manual de usuario o la calca en la propia rueda.

[Pincha en el modelo de buje o radios para acceder a la información de recambios](#)

## MOUNTAIN PERFORMANCE (MP)

## MP30 TEAM (desde MY2025)

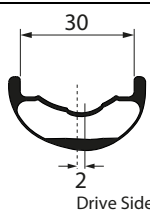
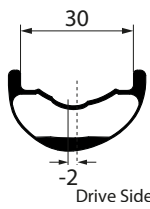
	MODELO	MATERIAL	TALLA	TIPO LLANTA	TIPO FRENO	TUBELESS	ANCHO INTERNO	OFFSET	AGUJEROS DIRECCIONALES	AGUJEROS RADIOS	ERD	ETRTO	UNIÓN	ANCHO CINTA TUBELESS	VÁLVULA	CUBIERTAS COMPATIBLES	PRESIÓN MÁXIMA	SECCIÓN	
LLANTAS	LLANTA DELANTERA	MP10-F-29-28H	Carbon	29"	Clincher Hookless	Disco	SI	30 mm	2 mm	SI	28	611 mm	622x30TSS	—	30 mm	44 mm	2.05"-2.8"	**	
	LLANTA TRASERA	MP10-R-29-28H	Carbon	29"	Clincher Hookless	Disco	SI	30 mm	-2 mm	SI	28	607.6 mm	622x30TSS	—	30 mm	44 mm	2.05"-2.8"	**	

	Nº RADIOS	MODELO	RADIADO DRIVE SIDE	RADIADO NON-DRIVE SIDE	LONGITUD RADIOS DRIVE SIDE	LONGITUD RADIOS NON-DRIVE SIDE	TENSIÓN MONTAJE DRIVE SIDE	TENSIÓN MONTAJE DISC SIDE	
RADIOS	DELANTERA	28	Sapim Sprint SP* Butted 2.0/1.7/2.0	3 Cruces	3 Cruces	305 mm	305 mm	—	1200 N
	TRASERA	28	Sapim Sprint SP* Butted 2.0/1.7/2.0	3 Cruces	3 Cruces	303 mm	303 mm	1300 N	—

BUJES	MODELO	SPACING (OLD)	EJE	TIPO DISCO	RADIOS	NÚCLEO	MECANISMO NÚCLEO	CABECILLAS	MODELO	MEDIDAS	ARANDELA CABECILLAS	PESO RUEDA	PESO	USO
BUJE DELANTERO	OQUO TEAM DT 350 INSIDE	Boost 110 mm	Pasante 15 mm	Center Lock	28 SP*	—	—	DELANTERA	Sapim Alloy Double Square	2x18 mm (14G)	No	DELANTERA	695gr +/-5%	<b>ASTM Condición 4</b> (Ver manual de usuario) Peso máximo del sistema (bicicleta + ciclista + equipación) = <b>110 kg.</b>
BUJE TRASERO	OQUO TEAM DT 350 INSIDE	Boost 148 mm	Pasante 12 mm	Center Lock	28 SP*	Sram XD or Shimano Microspline	DT Swiss Ratchet 10°/36	TRASERA	Sapim Alloy Double Square	2x18 mm (14G)	No	TRASERA	810gr +/-5%	

\* SP: Straightpull

\*\* Para conocer la presión máxima de la llanta, consulta el manual de usuario o la calca en la propia rueda.

[Pincha en el modelo de buje o radios para acceder a la información de recambios](#)

## MOUNTAIN PERFORMANCE (MP)

## MP28 PRO (hasta MY2023)

	MODELO	MATERIAL	TALLA	TIPO LLANTA	TIPO FRENO	TUBE-LESS	ANCHO INTERNO	OFFSET	AGUJEROS DIRECCIONALES	AGUJEROS RADIOS	ERD	ETRTO	UNIÓN	ANCHO CINTA TUBELESS	VÁLVULA	CUBIERTAS COMPATIBLES	PRESIÓN MÁXIMA	SECCIÓN	
LLANTAS	DELANTERA/ TRASERA	MP30-B- 29-28H	Aluminio AL6061	29"	Clincher Hookless	Disco	SI	28 mm	2 mm	SI	28	600 mm	622x28TSS	Sleeved	28 mm	40 mm	2"-2.55"	**	

	Nº RADIOS	MODELO	RADIADO DRIVE SIDE	RADIADO NON-DRIVE SIDE	LONGITUD RADIOS DRIVE SIDE	LONGITUD RADIOS NON-DRIVE SIDE	TENSIÓN MONTAJE DRIVE SIDE	TENSIÓN MONTAJE DISC SIDE	LEADING SPOKE DRIVE SIDE	TRAILING SPOKE DRIVE SIDE	LEADING SPOKE NON-DRIVE SIDE	TRAILING SPOKE NON-DRIVE SIDE
DELANTERA	28	Sapim Race Butted 14G (2 mm) J-Bend	3 Cruces	3 Cruces	298 mm	297 mm	—	1200 N	Por fuera	Por dentro	Por fuera	Por dentro
TRASERA	28	Sapim Race Butted 14G (2 mm) J-Bend	3 Cruces	3 Cruces	296 mm	297 mm	1200 N	—	Por dentro	Por fuera	Por fuera	Por dentro

	MODELO	SPACING (OLD)	EJE	TIPO DISCO	RADIOS	NÚCLEO	MECANISMO NÚCLEO		MODELO	MEDIDAS	ARANDELA CABECILLAS		RUEDA	PESO			
BUJES	BUJE DELANTERO	DT SWISS 350 Classic CL	Boost 110 mm	Pasante 15 mm	Center Lock	28 J-Bend	—	—	CABECILLAS	DELANTERA	Sapim Brass Polyax	2x14 mm (14G)	No	PESO RUEDA	DELANTERA	850gr +/-5%	USO  ASTM Condición 4 (Ver manual de usuario) Peso máximo del sistema (bicicleta + ciclista + equipación) = <b>110 kg.</b>
	BUJE TRASERO	DT SWISS 350 Classic CL	Boost 148 mm	Pasante 12 mm	Center Lock	28 J-Bend	Sram XD Shimano Microspline Shimano HG	Ratchet 36		TRASERA	Sapim Brass Polyax	2x14 mm (14G)	No		TRASERA	955gr +/-5%	

\*\* Para conocer la presión máxima de la llanta, consulta el manual de usuario o la calca en la propia rueda.

[Pincha en el modelo de buje o radios para acceder a la información de recambios](#)

## MOUNTAIN PERFORMANCE (MP)

## MP28 PRO (desde MY2024)

	MODELO	MATERIAL	TALLA	TIPO LLANTA	TIPO FRENO	TUBE-LESS	ANCHO INTERNO	OFFSET	AGUJEROS DIRECCIONALES	AGUJEROS RADIOS	ERD	ETRTO	UNIÓN	ANCHO CINTA TUBELESS	VÁLVULA	CUBIERTAS COMPATIBLES	PRESIÓN MÁXIMA	SECCIÓN	
LLANTAS	DELANTERA/ TRASERA	MP31-B- 29-28H	Aluminio AL6061	29"	Clincher Hookless	Disco	SI	28 mm	2 mm	SI	28	600 mm	622x28TSS	Sleeved	28 mm	40 mm	2"-2.55"	**	 

	Nº RADIOS	MODELO	RADIADO DRIVE SIDE	RADIADO NON-DRIVE SIDE	LONGITUD RADIOS DRIVE SIDE	LONGITUD RADIOS NON-DRIVE SIDE	TENSIÓN MONTAJE DRIVE SIDE	TENSIÓN MONTAJE DISC SIDE	LEADING SPOKE DRIVE SIDE	TRAILING SPOKE DRIVE SIDE	LEADING SPOKE NON-DRIVE SIDE	TRAILING SPOKE NON-DRIVE SIDE
DELANTERA	28	Sapim Race Butted 14G (2 mm) J-Bend	3 Cruces	3 Cruces	297 mm	296 mm	—	1200 N	Por fuera	Por dentro	Por fuera	Por dentro
TRASERA	28	Sapim Race Butted 14G (2 mm) J-Bend	3 Cruces	3 Cruces	296 mm	296 mm	1200 N	—	Por dentro	Por fuera	Por fuera	Por dentro

BUJES	MODELO	SPACING (OLD)	EJE	TIPO DISCO	RADIOS	NÚCLEO	MECANISMO NÚCLEO	CABECILLAS	MODELO	MEDIDAS	ARANDELA CABECILLAS	PESO RUEDA	RUEDA	PESO	USO
	BUJE DELANTERO	DT SWISS 370 Classic IS	Boost 110 mm	Pasante 15 mm	6-Bolt	28 J-Bend	—		—	DELANTERA	Sapim Brass Polyax		2x14 mm (14G)	No	
BUJE TRASERO	DT SWISS 370 Classic IS	Boost 110 mm	Pasante 15 mm	6-Bolt	28 J-Bend	Sram XD Shimano Microspline	Ratchet LN 18	TRASERA	Sapim Brass Polyax	2x14 mm (14G)	No	TRASERA	1040gr +/-5%		

\*\* Para conocer la presión máxima de la llanta, consulta el manual de usuario o la calca en la propia rueda.

[Pincha en el modelo de buje o radios para acceder a la información de recambios](#)

**ASTM Condición 4**  
(Ver manual de usuario)  
Peso máximo del sistema  
(bicicleta + ciclista +  
equipación) =  
**110 kg.**

## MOUNTAIN CONTROL (MC)

## MC32 LTD (hasta MY2025)

	MODELO	MATERIAL	TALLA	TIPO LLANTA	TIPO FRENO	TUBELESS	ANCHO INTERNO	OFFSET	AGUJEROS DIRECCIONALES	AGUJEROS RADIOS	ERD	ETRTO	UNIÓN	ANCHO CINTA TUBELESS	VÁLVULA	CUBIERTAS COMPATIBLES	PRESIÓN MÁXIMA	SECCIÓN	
LLANTAS	LLANTA DELANTERA	MC10-F-29-28H	Carbon	29"	Clincher Hookless	Disco	SI	32 mm	2 mm	SI	28	604.26 mm	622x32TSS	—	32 mm	44 mm	2.4"-2.8"	**	
	LLANTA TRASERA	MC10-R-29-32H	Carbon	29"	Clincher Hookless	Disco	SI	30 mm	-2 mm	SI	32	599.86 mm	622x30TSS	—	30mm	44 mm 57 mm en Wild con imán en válvula	2.05"-2.8"	**	

	Nº RADIOS	MODELO	RADIADO DRIVE SIDE	RADIADO NON-DRIVE SIDE	LONGITUD RADIOS DRIVE SIDE	LONGITUD RADIOS NON-DRIVE SIDE	TENSIÓN MONTAJE DRIVE SIDE	TENSIÓN MONTAJE DISC SIDE	LEADING SPOKE DRIVE SIDE	TRAILING SPOKE DRIVE SIDE	LEADING SPOKE NON-DRIVE SIDE	TRAILING SPOKE NON-DRIVE SIDE
DELANTERA	28	Sapim D-Sprint Butted. 14G (2 mm) J-Bend	3 Cruces	3 Cruces	301 mm	298 mm	—	1200 N	Por fuera	Por dentro	Por fuera	Por dentro
TRASERA	32	Sapim D-Sprint Butted. 14G (2 mm) J-Bend	3 Cruces	3 Cruces	292 mm	292 mm	1300 N	—	Por dentro	Por fuera	Por fuera	Por dentro

BUJES	MODELO	SPACING (OLD)	EJE	TIPO DISCO	RADIOS	NÚCLEO	MECANISMO NÚCLEO	CABECILLAS	MODELO	MEDIDAS	ARANDELA CABECILLAS	PESO RUEDA	PESO	USO
BUJE DELANTERO	DT SWISS 350 Classic IS	Boost 110 mm	Pasante 15 mm	6-Bolt	28 J-Bend	—	—	DELANTERA	Sapim Brass Polyax	2x14 mm (14G)	No	DELANTERA	860gr +/-5%	ASTM Condición 5 (Ver manual de usuario) Peso máximo del sistema (bicicleta + ciclista + equipación) = <b>135 kg.</b>
BUJE TRASERO	DT SWISS 350 Classic IS	Boost 148 mm	Pasante 12mm	6-Bolt	32J-Bend	Sram XD Shimano MS	Ratchet 36	TRASERA	Sapim Brass Polyax	2x14 mm (14G)	No	TRASERA	1042gr +/-5%	

\*\* Para conocer la presión máxima de la llanta, consulta el manual de usuario o la calca en la propia rueda.

[Pincha en el modelo de buje o radios para acceder a la información de recambios](#)

## MOUNTAIN CONTROL (MC)

## MC32 LTD (desde MY2026)

	MODELO	MATERIAL	TALLA	TIPO LLANTA	TIPO FRENO	TUBELESS	ANCHO INTERNO	OFFSET	AGUJEROS DIRECCIONALES	AGUJEROS RADIOS	ERD	ETRTO	UNIÓN	ANCHO CINTA TUBELESS	VÁLVULA	CUBIERTAS COMPATIBLES	PRESIÓN MÁXIMA	SECCIÓN	
LLANTAS	LLANTA DELANTERA	MC10-F-29-28H	Carbon	29"	Clincher Hookless	Disco	SI	32 mm	2 mm	SI	28	604.26 mm	622x32TSS	—	32 mm	44 mm	2.4"-2.8"	**	
	LLANTA TRASERA	MC10-R-29-32H	Carbon	29"	Clincher Hookless	Disco	SI	30 mm	-2 mm	SI	32	599.86 mm	622x30TSS-S	—	30mm	44 mm 57 mm en Wild con imán en válvula	2.05"-2.8"	**	

	Nº RADIOS	MODELO	RADIADO DRIVE SIDE	RADIADO NON-DRIVE SIDE	LONGITUD RADIOS DRIVE SIDE	LONGITUD RADIOS NON-DRIVE SIDE	TENSIÓN MONTAJE DRIVE SIDE	TENSIÓN MONTAJE DISC SIDE	LEADING SPOKE DRIVE SIDE	TRAILING SPOKE DRIVE SIDE	LEADING SPOKE NON-DRIVE SIDE	TRAILING SPOKE NON-DRIVE SIDE
DELANTERA	28	Sapim Sprint Butted. 14G (2 mm) J-Bend	3 Cruces	3 Cruces	299 mm	299 mm	—	1200 N	Por fuera	Por dentro	Por fuera	Por dentro
TRASERA	32	Sapim Race Butted. 14G (2 mm) J-Bend	3 Cruces	3 Cruces	291 mm	291 mm	1300 N	—	Por dentro	Por fuera	Por fuera	Por dentro

BUJES	MODELO	SPACING (OLD)	EJE	TIPO DISCO	RADIOS	NÚCLEO	MECANISMO NÚCLEO	CABECILLAS	MODELO	MEDIDAS	ARANDELA CABECILLAS	PESO RUEDA	PESO	USO
BUJE DELANTERO	OQUO LTD DT 350 INSIDE	Boost 110 mm	Pasante 15 mm	6-Bolt	28 J-Bend	—	—	DELANTERA	Sapim Brass Polyax	2x14 mm (14G)	No	DELANTERA	860gr +/-5%	ASTM Condición 5 (Ver manual de usuario) Peso máximo del sistema (bicicleta + ciclista + equipación) = <b>135 kg.</b>
BUJE TRASERO	OQUO LTD DT 350 DEG INSIDE	Boost 148 mm	Pasante 12mm	6-Bolt	32 J-Bend	Sram XD Shimano MS	Ratchet DEG 72	TRASERA	Sapim Brass Polyax	2x14 mm (14G)	No	TRASERA	1042gr +/-5%	

\*\* Para conocer la presión máxima de la llanta, consulta el manual de usuario o la calca en la propia rueda.

[Pincha en el modelo de buje o radios para acceder a la información de recambios](#)

## MOUNTAIN CONTROL (MC)

## MC32 LTD POWER (hasta MY2023)

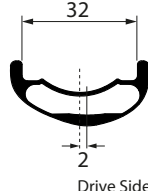
LLANTAS	MODELO	MATERIAL	TALLA	TIPO LLANTA	TIPO FRENO	TUBELESS	INTERNAL WIDTH	OFFSET	AGUJEROS DIRECCIONALES	AGUJEROS RADIOS	ERD	ETRTO	UNIÓN	ANCHO CINTA TUBELESS	VÁLVULA	CUBIERTAS COMPATIBLES	PRESIÓN MÁXIMA	SECCIÓN
LLANTA TRASERA	MC10-R-29-32H	Carbon	29"	Clincher Hookless	Disco	SI	30 mm	-2 mm	SI	32	599.86 mm	622x30TSS	—	30mm	44 mm 57 mm en Wild con imán en válvula	2.05"-2.8"	**	 32 2 Drive Side

RADIOS	Nº RADIOS	MODELO	RADIADO DRIVE SIDE	RADIADO NON-DRIVE SIDE	LONGITUD RADIOS DRIVE SIDE	LONGITUD RADIOS NON-DRIVE SIDE	TENSIÓN MONTAJE DRIVE SIDE	TENSIÓN MONTAJE DISC SIDE	LEADING SPOKE DRIVE SIDE	TRAILING SPOKE DRIVE SIDE	LEADING SPOKE NON-DRIVE SIDE	TRAILING SPOKE NON-DRIVE SIDE
TRASERA	32	Sapim E-Light. Butted 14G (2 mm) J-Bend	3 Cruces	3 Cruces	292 mm	294 mm	1300 N	—	Por dentro	Por fuera	Por fuera	Por dentro

BUJES	MODELO	SPACING (OLD)	EJE	TIPO DISCO	RADIOS	NÚCLEO	MECANISMO NÚCLEO	CABECILLAS	MODELO	MEDIDAS	ARANDELA CABECILLAS	PESO RUEDA	PESO	USO
BUJE TRASERO	DT SWISS 350 Hybrid Classic IS modelo hasta MY2023	Boost 148 mm	Pasante 12mm	6-Bolt	32	Sram XD Shimano MS	Ratchet 24	TRASERA	Sapim Brass Polyax	2x14 mm (14G)	No	TRASERA	1042gr +/-5%	ASTM Condición 5 (Ver manual de usuario)  Peso máximo del sistema (bicicleta + ciclista + equipación) = <b>135 kg.</b>

\*\* Para conocer la presión máxima de la llanta, consulta el manual de usuario o la calca en la propia rueda.

[Pincha en el modelo de buje o radios para acceder a la información de recambios](#)

## MOUNTAIN CONTROL (MC)

## MC32 LTD POWER (desde MY2024)

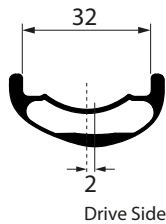
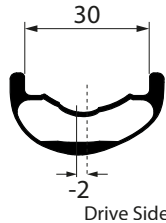
	MODELO	MATERIAL	TALLA	TIPO LLANTA	TIPO FRENO	TUBELESS	INTERNAL WIDTH	OFFSET	AGUJEROS DIRECCIONALES	AGUJEROS RADIOS	ERD	ETRTO	UNIÓN	ANCHO CINTA TUBELESS	VÁLVULA	CUBIERTAS COMPATIBLES	PRESIÓN MÁXIMA	SECCIÓN	
LLANTAS	LLANTA DELANTERA	MC10-F-29-28H	Carbon	29"	Clincher Hookless	Disco	SI	32 mm	2 mm	SI	28	604.26 mm	622x32TSS	—	32 mm	44 mm	2.4"-2.8"	**	
	LLANTA TRASERA	MC10-R-29-32H	Carbon	29"	Clincher Hookless	Disco	SI	30 mm	-2 mm	SI	32	599.86 mm	622x30TSS	—	30mm	44 mm 57 mm en Wild con imán en válvula	2.05"-2.8"	**b	

	Nº RADIOS	MODELO	RADIADO DRIVE SIDE	RADIADO NON-DRIVE SIDE	LONGITUD RADIOS DRIVE SIDE	LONGITUD RADIOS NON-DRIVE SIDE	TENSIÓN MONTAJE DRIVE SIDE	TENSIÓN MONTAJE DISC SIDE	LEADING SPOKE DRIVE SIDE	TRAILING SPOKE DRIVE SIDE	LEADING SPOKE NON-DRIVE SIDE	TRAILING SPOKE NON-DRIVE SIDE	
RADIOS	DELANTERA	28	Sapim E-Light, Butted 14G (2 mm) J-Bend	3 Cruces	3 Cruces	299 mm	298 mm	—	1300 N	Por fuera	Por dentro	Por fuera	Por dentro
	TRASERA	32	Sapim E-Light, Butted 14G (2 mm) J-Bend	3 Cruces	3 Cruces	291 mm	292 mm	1300 N	—	Por dentro	Por fuera	Por fuera	Por dentro

	MODELO	SPACING (OLD)	EJE	TIPO DISCO	RADIOS	NÚCLEO	MECANISMO NÚCLEO		MODELO	MEDIDAS	ARANDELA CABECILLAS		RUEDA	PESO			
BUJES	BUJE DELANTERO	DT SWISS 350 Hybrid Classic IS modelo desde MY2024	Boost 110 mm	Pasante 15mm	6-Bolt	28	—		CABECILLAS	DELANTERA	Sapim Brass Polyax	2x14 mm (14G)	No	PESO RUEDA	DELANTERA	910gr +/-5%	USO
	BUJE TRASERO	DT SWISS 350 Hybrid Classic IS modelo desde MY2024	Boost 148 mm	Pasante 12mm	6-Bolt	32	Sram XD Shimano MS	Ratchet 24		TRASERA	Sapim Brass Polyax	2x14 mm (14G)	No		TRASERA	1056gr +/-5%	

**ASTM Condición 5**  
(Ver manual de usuario)

Peso máximo del sistema  
(bicicleta + ciclista +  
equipación) =  
**135 kg.**

\*\* Para conocer la presión máxima de la llanta, consulta el manual de usuario o la calca en la propia rueda.

[Pincha en el modelo de buje o radios para acceder a la información de recambios](#)

## MOUNTAIN CONTROL (MC)

## MC32 TEAM (hasta MY2024)

	MODELO	MATERIAL	TALLA	TIPO LLANTA	TIPO FRENO	TUBELESS	ANCHO INTERNO	OFFSET	AGUJEROS DIRECCIONALES	AGUJEROS RADIOS	ERD	ETRTO	UNIÓN	ANCHO CINTA TUBELESS	VÁLVULA	CUBIERTAS COMPATIBLES	PRESIÓN MÁXIMA	SECCIÓN	
LLANTAS	LLANTA DELANTERA 29"	MC30-F-29-28H	Aluminio AL6061	29"	Clincher Hookless	Disco	SI	32 mm	2 mm	SI	28	604 mm	622x32TSS	Sleeved	32 mm	44 mm	2.4"-2.8"	**	
	LLANTA TRASERA 29"	MC30-R-29-32H	Aluminio AL6061	29"	Clincher Hookless	Disco	SI	30 mm	-2 mm	SI	32	600 mm	622x30TSS	Sleeved	30 mm	44 mm 57 mm en Wild con imán en válvula	2.05"-2.8"	**	
	LLANTA TRASERA 27.5"	MC31-R-27-32H	Aluminio AL6061	27.5"	Clincher Hookless	Disco	SI	30 mm	-2 mm	SI	32	561.6 mm	584x30TSS	Sleeved	30 mm	44 mm 57 mm en Wild con imán en válvula	2.05"-2.8"	**	

	Nº RADIOS	MODELO	RADIADO DRIVE SIDE	RADIADO NON-DRIVE SIDE	LONGITUD RADIOS DRIVE SIDE	LONGITUD RADIOS NON-DRIVE SIDE	TENSIÓN MONTAJE DRIVE SIDE	TENSIÓN MONTAJE DISC SIDE	LEADING SPOKE DRIVE SIDE	TRAILING SPOKE DRIVE SIDE	LEADING SPOKE NON-DRIVE SIDE	TRAILING SPOKE NON-DRIVE SIDE	
RADIOS	DELANTERA 29"	28	Sapim D-Sprint Butted. 14G (2 mm). J-Bend	3 Cruces	3 Cruces	299 mm	297 mm	—	1200 N	Por fuera	Por dentro	Por fuera	Por dentro
	TRASERA 29"	32	Sapim Race Butted. 14G (2 mm). J-Bend	3 Cruces	3 Cruces	291 mm	291 mm	1200 N	—	Por dentro	Por fuera	Por fuera	Por dentro
	TRASERA 27.5"	32	Sapim Race Butted. 14G (2 mm). J-Bend	3 Cruces	3 Cruces	271 mm	271 mm	1200 N	—	Por dentro	Por fuera	Por fuera	Por dentro

BUJES	MODELO	SPACING (OLD)	EJE	TIPO DISCO	RADIOS	NÚCLEO	MECANISMO NÚCLEO	CABECILLAS	MODELO	MEDIDAS	ARANDELA CABECILLAS	PESO RUEDA	RUEDA	PESO	USO		
	DELANTERA 29"	DT SWISS 350 Classic IS	Boost 110 mm	Pasante 15 mm	6-Bolt	28 J-Bend	—		—	DELANTERA 29"	Sapim Brass Polyax		2x14 mm (14G)	No		DELANTERA 29"	898gr +/-5%
	TRASERA 29"	DT SWISS 350 Classic IS	Boost 148 mm	Pasante 12 mm	6-Bolt	32 J-Bend	Sram XD or Shimano MS		Ratchet 36	TRASERA 29"	Sapim Brass Polyax		2x14 mm (14G)	No		TRASERA 29"	1046gr +/-5%
	TRASERA 27.5"	DT SWISS 350 Classic IS	Boost 148 mm	Pasante 12 mm	6-Bolt	32 J-Bend	Sram XD or Shimano MS		Ratchet 36	TRASERA 27.5"	Sapim Brass Polyax		2x14 mm (14G)	No		TRASERA 27.5"	1010gr +/-5%

**ASTM Condición 5**  
(Ver manual de usuario)  
Peso máximo del sistema  
(bicicleta + ciclista +  
equipación) =  
**135 kg.**

\*\* Para conocer la presión máxima de la llanta, consulta el manual de usuario o la calca en la propia rueda.

[Pincha en el modelo de buje o radios para acceder a la información de recambios](#)

## MOUNTAIN CONTROL (MC)

## MC32 TEAM (MY2025)

	MODELO	MATERIAL	TALLA	TIPO LLANTA	TIPO FRENO	TUBELESS	ANCHO INTERNO	OFFSET	AGUJEROS DIRECCIONALES	AGUJEROS RADIOS	ERD	ETRTO	UNIÓN	ANCHO CINTA TUBELESS	VÁLVULA	CUBIERTAS COMPATIBLES	PRESIÓN MÁXIMA	SECCIÓN	
LLANTAS	LLANTA DELANTERA 29"	MC36-F-29-28H	Aluminio AL6061	29"	Clincher Hookless	Disco	SI	32 mm	2 mm	SI	28	612,3 mm	622x32TSS	Sleeved	32 mm	44 mm	2.4"-2.8"	**	
	LLANTA TRASERA 29"	MC36-R-29-32H	Aluminio AL6061	29"	Clincher Hookless	Disco	SI	30 mm	-2 mm	SI	32	610,9 mm	622x30TSS	Sleeved	30 mm	44 mm 57 mm en Wild con imán en válvula	2.05"-2.8"	**	
	LLANTA TRASERA 27.5"	MC37-R-27-32H	Aluminio AL6061	27.5"	Clincher Hookless	Disco	SI	30 mm	-2 mm	SI	32	572,9 mm	584x30TSS	Sleeved	30 mm	44 mm 57 mm en Wild con imán en válvula	2.05"-2.8"	**	

	Nº RADIOS	MODELO	RADIADO DRIVE SIDE	RADIADO NON-DRIVE SIDE	LONGITUD RADIOS DRIVE SIDE	LONGITUD RADIOS NON-DRIVE SIDE	TENSIÓN MONTAJE DRIVE SIDE	TENSIÓN MONTAJE DISC SIDE	LEADING SPOKE DRIVE SIDE	TRAILING SPOKE DRIVE SIDE	LEADING SPOKE NON-DRIVE SIDE	TRAILING SPOKE NON-DRIVE SIDE
RADIOS	DELANTERA 29"	28	Sapim D-Light Butted. 14G (2 mm). J-Bend	3 Cruces	3 Cruces	302 mm	300 mm	—	1300 N	Por fuera	Por dentro	Por fuera Por dentro
	TRASERA 29"	32	Sapim Sprint Butted. 14G (2 mm). J-Bend	3 Cruces	3 Cruces	295 mm	295 mm	1300 N	—	Por dentro	Por fuera	Por fuera Por dentro
	TRASERA 27.5"	32	Sapim Sprint Butted. 14G (2 mm). J-Bend	3 Cruces	3 Cruces	276 mm	276 mm	1300 N	—	Por dentro	Por fuera	Por fuera Por dentro

	MODELO	SPACING (OLD)	EJE	TIPO DISCO	RADIOS	NÚCLEO	MECANISMO NÚCLEO
BUJES	DELANTERA 29"	DT SWISS 350 Classic IS	Boost 110 mm	Pasante 15 mm	6-Bolt	28 J-Bend	—
	TRASERA 29"	DT SWISS 350 Classic IS	Boost 148 mm	Pasante 12 mm	6-Bolt	32 J-Bend	Sram XD or Shimano MS
	TRASERA 27.5"	DT SWISS 350 Classic IS	Boost 148 mm	Pasante 12 mm	6-Bolt	32 J-Bend	Sram XD or Shimano MS

	MODELO	MEDIDAS	ARANDELA CABECILLAS
CABECILLAS	DELANTERA 29"	Sapim Alloy Double Square	2x18 mm (14G)
	TRASERA 29"	Sapim Alloy Double Square	2x18 mm (14G)
	TRASERA 27.5"	Sapim Alloy Double Square	2x18 mm (14G)

	RUEDA	PESO
PESO RUEDA	DELANTERA 29"	970gr +/-5%
	TRASERA 29"	1108gr +/-5%
	TRASERA 27.5"	1055gr +/-5%

USO
<p><b>ASTM Condición 5</b> (Ver manual de usuario)</p> <p>Peso máximo del sistema (bicicleta + ciclista + equipación) = <b>135 kg.</b></p>

\*\* Para conocer la presión máxima de la llanta, consulta el manual de usuario o la calca en la propia rueda.

[Pincha en el modelo de buje o radios para acceder a la información de recambios](#)

## MOUNTAIN CONTROL (MC)

## MC32 TEAM (desde MY2026)

	MODELO	MATERIAL	TALLA	TIPO LLANTA	TIPO FRENO	TUBELESS	ANCHO INTERNO	OFFSET	AGUJEROS DIRECCIONALES	AGUJEROS RADIOS	ERD	ETRTO	UNIÓN	ANCHO CINTA TUBELESS	VÁLVULA	CUBIERTAS COMPATIBLES	PRESIÓN MÁXIMA	SECCIÓN	
LLANTAS	LLANTA DELANTERA 29"	MC36-F-29-28H	Aluminio AL6061	29"	Clincher Minihook	Disco	SI	32 mm	2 mm	SI	28	612,3 mm	622x32TSS	Sleeved	32 mm	44 mm	2.4"-2.8"	**	
	LLANTA TRASERA 29"	MC36-R-29-32H	Aluminio AL6061	29"	Clincher Minihook	Disco	SI	30 mm	-2 mm	SI	32	610,9 mm	622x30TSS	Sleeved	30 mm	44 mm Wild con imán en válvula	2.05"-2.8"	**	
	LLANTA TRASERA 27.5"	MC37-R-27-32H	Aluminio AL6061	27.5"	Clincher Minihook	Disco	SI	30 mm	-2 mm	SI	32	572,9 mm	584x30TSS	Sleeved	30 mm	44 mm Wild con imán en válvula	2.05"-2.8"	**	

	Nº RADIOS	MODELO	RADIADO DRIVE SIDE	RADIADO NON-DRIVE SIDE	LONGITUD RADIOS DRIVE SIDE	LONGITUD RADIOS NON-DRIVE SIDE	TENSIÓN MONTAJE DRIVE SIDE	TENSIÓN MONTAJE DISC SIDE	LEADING SPOKE DRIVE SIDE	TRAILING SPOKE DRIVE SIDE	LEADING SPOKE NON-DRIVE SIDE	TRAILING SPOKE NON-DRIVE SIDE	
RADIOS	DELANTERA 29"	28	Sapim D-Light Butted. 14G (2 mm). J-Bend	3 Cruces	3 Cruces	298 mm	297 mm	—	1300 N	Por fuera	Por dentro	Por fuera	Por dentro
	TRASERA 29"	32	Sapim Sprint Butted. 14G (2 mm). J-Bend	3 Cruces	3 Cruces	291 mm	291 mm	1300 N	—	Por dentro	Por fuera	Por fuera	Por dentro
	TRASERA 27.5"	32	Sapim Sprint Butted. 14G (2 mm). J-Bend	3 Cruces	3 Cruces	272 mm	272 mm	1300 N	—	Por dentro	Por fuera	Por fuera	Por dentro

BUJES	MODELO	SPACING (OLD)	EJE	TIPO DISCO	RADIOS	NÚCLEO	MECANISMO NÚCLEO	CABECILLAS	MODELO	MEDIDAS	ARANDELA CABECILLAS	PESO RUEDA	RUEDA	PESO	USO		
	DELANTERA 29"	OQUO LTD DT 350 INSIDE	Boost 110 mm	Pasante 15 mm	6-Bolt	28 J-Bend	—		—	DELANTERA 29"	Sapim Alloy Double Square		2x18 mm (14G)	No		DELANTERA 29"	950gr +/-5%
	TRASERA 29"	OQUO LTD DT 350 DEG INSIDE	Boost 148 mm	Pasante 12 mm	6-Bolt	32 J-Bend	Sram XD or Shimano MS		Ratchet DEG 72	TRASERA 29"	Sapim Alloy Double Square		2x18 mm (14G)	No		TRASERA 29"	1125gr +/-5%
TRASERA 27.5"	OQUO LTD DT 350 DEG INSIDE	Boost 148 mm	Pasante 12 mm	6-Bolt	32 J-Bend	Sram XD or Shimano MS	Ratchet DEG 72	TRASERA 27.5"	Sapim Alloy Double Square	2x18 mm (14G)	No	TRASERA 27.5"	1075gr +/-5%				

**ASTM Condición 5**  
(Ver manual de usuario)

Peso máximo del sistema  
(bicicleta + ciclista + equipación) =  
**135 kg.**

\*\* Para conocer la presión máxima de la llanta, consulta el manual de usuario o la calca en la propia rueda.

[Pincha en el modelo de buje o radios para acceder a la información de recambios](#)

## MOUNTAIN CONTROL (MC)

## MC32 TEAM RALLON DH MY2026 (OEM)

## AVISO

Esta variable de las ruedas MC32TEAM sólo está disponible en montajes de bicicleta completa Orbea Rallon DH MY2026.

	MODELO	MATERIAL	TALLA	TIPO LLANTA	TIPO FRENO	TUBELESS	ANCHO INTERNO	OFFSET	AGUJEROS DIRECCIONALES	AGUJEROS RADIOS	ERD	ETRTO	UNIÓN	ANCHO CINTA TUBELESS	VÁLVULA	CUBIERTAS COMPATIBLES	PRESIÓN MÁXIMA	SECCIÓN	
LLANTAS	LLANTA DELANTERA 29"	MC36-F-29-28H	Aluminio AL6061	29"	Clincher Minihook	Disco	SI	32 mm	2 mm	SI	28	612,3 mm	622x32TSS	Sleeved	32 mm	44 mm	2.4"-2.8"	**	
	LLANTA TRASERA 27.5"	MC37-R-27-32H	Aluminio AL6061	27.5"	Clincher Minihook	Disco	SI	30 mm	-2 mm	SI	32	572,9 mm	584x30TSS	Sleeved	30 mm	44 mm 57 mm en Wild con imán en válvula	2.05"-2.8"	**	

	Nº RADIOS	MODELO	RADIADO DRIVE SIDE	RADIADO NON-DRIVE SIDE	LONGITUD RADIOS DRIVE SIDE	LONGITUD RADIOS NON-DRIVE SIDE	TENSIÓN MONTAJE DRIVE SIDE	TENSIÓN MONTAJE DISC SIDE	LEADING SPOKE DRIVE SIDE	TRAILING SPOKE DRIVE SIDE	LEADING SPOKE NON-DRIVE SIDE	TRAILING SPOKE NON-DRIVE SIDE
RADIOS	DELANTERA 29"	28	Sapim Race Butted. 14G (2 mm). J-Bend	3 Cruces	3 Cruces	296 mm	296 mm	—	1300 N	Por fuera	Por dentro	Por fuera Por dentro
	TRASERA 27.5"	32	Sapim Race Butted. 14G (2 mm). J-Bend	3 Cruces	3 Cruces	272 mm	272 mm	1300 N	—	Por dentro	Por fuera	Por fuera Por dentro

BUJES	MODELO	SPACING (OLD)	EJE	TIPO DISCO	RADIOS	NÚCLEO	MECANISMO NÚCLEO	CABECILLAS	MODELO	MEDIDAS	ARANDELA CABECILLAS	PESO RUEDA	RUEDA	PESO	USO
	DELANTERA 29"	DT SWISS 350 Classic IS	Boost 110 mm	Pasante 20 mm	6-Bolt	28 J-Bend	—		—	DELANTERA 29"	Sapim Brass Polyax		2x14 mm (14G)	No	
TRASERA 27.5"	DT SWISS 350 Classic IS	Boost 148 mm	Pasante 12 mm	6-Bolt	32 J-Bend	Shimano HG	Ratchet 36 SL	TRASERA 27.5"	Sapim Brass Polyax	2x14 mm (14G)	No	TRASERA 27.5"	1055gr +/-5%		

**ASTM Condición 5**  
(Ver manual de usuario)  
Peso máximo del sistema  
(bicicleta + ciclista +  
equipación) =  
**135 kg.**

\*\* Para conocer la presión máxima de la llanta, consulta el manual de usuario o la calca en la propia rueda.

[Pincha en el modelo de buje o radios para acceder a la información de recambios](#)

## MOUNTAIN CONTROL (MC)

## MC32 TEAM POWER (hasta MY2023)

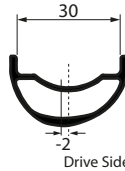
	MODELO	MATERIAL	TALLA	TIPO LLANTA	TIPO FRENO	TUBELESS	INTERNAL WIDTH	OFFSET	AGUJEROS DIRECCIONALES	AGUJEROS RADIOS	ERD	ETRT0	UNIÓN	ANCHO CINTA TUBELESS	VÁLVULA	CUBIERTAS COMPATIBLES	PRESIÓN MÁXIMA	SECCIÓN	
LLANTAS	LLANTA DELANTERA	MC31-F-29-32H	Aluminio AL6061	29"	Clincher Hookless	Disco	SI	32 mm	2 mm	SI	32	604 mm	622x32TSS	Sleeved	32 mm	44 mm	2.4"-2.8"	**	
	LLANTA TRASERA	MC30-R-29-32H	Aluminio AL6061	29"	Clincher Hookless	Disco	SI	30 mm	-2 mm	SI	32	600 mm	622x30TSS	Sleeved	30mm	44 mm 57 mm en Wild con imán en válvula	2.05"-2.8"	**	

	Nº RADIOS	MODELO	RADIADO DRIVE SIDE	RADIADO NON-DRIVE SIDE	LONGITUD RADIOS DRIVE SIDE	LONGITUD RADIOS NON-DRIVE SIDE	TENSIÓN MONTAJE DRIVE SIDE	TENSIÓN MONTAJE DISC SIDE	LEADING SPOKE DRIVE SIDE	TRAILING SPOKE DRIVE SIDE	LEADING SPOKE NON-DRIVE SIDE	TRAILING SPOKE NON-DRIVE SIDE	
RADIOS	DELANTERA	32	Sapim E-Light, Butted 14G (2 mm) J-Bend	3 Cruces	3 Cruces	294 mm	292 mm	—	1200 N	Por fuera	Por dentro	Por fuera	Por dentro
	TRASERA	32	Sapim E-Light, Butted 14G (2 mm) J-Bend	3 Cruces	3 Cruces	291 mm	293 mm	1200 N	—	Por dentro	Por fuera	Por fuera	Por dentro

BUJES	MODELO	SPACING (OLD)	EJE	TIPO DISCO	RADIOS	NÚCLEO	MECANISMO NÚCLEO	CABECILLAS	MODELO	MEDIDAS	ARANDELA CABECILLAS	PESO RUEDA	RUEDA	PESO	USO
	BUJE DELANTERO	DT SWISS 350 Hybrid Classic IS modelo hasta MY2023	Boost 110 mm	Pasante 15mm	6-Bolt	32	—		—	DELANTERA	Sapim Brass Polyax		2x14 mm (14G)	No	
BUJE TRASERO	DT SWISS 350 Hybrid Classic IS modelo hasta MY2023	Boost 148 mm	Pasante 12mm	6-Bolt	32	Sram XD Shimano MS	Ratchet 24	TRASERA	Sapim Brass Polyax	2x14 mm (14G)	No	TRASERA	1060gr +/-5%		

\*\* Para conocer la presión máxima de la llanta, consulta el manual de usuario o la calca en la propia rueda.

[Pincha en el modelo de buje o radios para acceder a la información de recambios](#)

**ASTM Condición 5**  
(Ver manual de usuario)  
Peso máximo del sistema  
(bicicleta + ciclista +  
equipación) =  
**135 kg.**

## MOUNTAIN CONTROL (MC)

## MC32 TEAM POWER (MY2024)

	MODELO	MATERIAL	TALLA	TIPO LLANTA	TIPO FRENO	TUBELESS	ANCHO INTERNO	OFFSET	AGUJEROS DIRECCIONALES	AGUJEROS RADIOS	ERD	ETRTO	UNIÓN	ANCHO CINTA TUBELESS	VÁLVULA	CUBIERTAS COMPATIBLES	PRESIÓN MÁXIMA	SECCIÓN	
LLANTAS	LLANTA DELANTERA 29"	MC30-F-29-28H	Aluminio AL6061	29"	Clincher Hookless	Disco	SI	32 mm	2 mm	SI	28	604 mm	622x32TSS	Sleeved	32 mm	44 mm	2.4"-2.8"	**	
	LLANTA TRASERA 29"	MC30-R-29-32H	Aluminio AL6061	29"	Clincher Hookless	Disco	SI	30 mm	-2 mm	SI	32	600 mm	622x30TSS	Sleeved	30 mm	44 mm 57 mm en Wild con imán en válvula	2.05"-2.8"	**	
	LLANTA TRASERA 27.5"	MC31-R-27-32H	Aluminio AL6061	27.5"	Clincher Hookless	Disco	SI	30 mm	-2 mm	SI	32	561.6 mm	584x30TSS	Sleeved	30 mm	44 mm 57 mm en Wild con imán en válvula	2.05"-2.8"	**	

	Nº RADIOS	MODELO	RADIADO DRIVE SIDE	RADIADO NON-DRIVE SIDE	LONGITUD RADIOS DRIVE SIDE	LONGITUD RADIOS NON-DRIVE SIDE	TENSIÓN MONTAJE DRIVE SIDE	TENSIÓN MONTAJE DISC SIDE	LEADING SPOKE DRIVE SIDE	TRAILING SPOKE DRIVE SIDE	LEADING SPOKE NON-DRIVE SIDE	TRAILING SPOKE NON-DRIVE SIDE
RADIOS	DELANTERA 29"	28	Sapim E-Light. Butted 14G (2 mm) J-Bend	3 Cruces	3 Cruces	298 mm	297 mm	—	1200 N	Por fuera	Por dentro	Por fuera Por dentro
	TRASERA 29"	32	Sapim E-Light. Butted 14G (2 mm) J-Bend	3 Cruces	3 Cruces	291 mm	292 mm	1200 N	—	Por dentro	Por fuera	Por fuera Por dentro
	TRASERA 27.5"	32	Sapim E-Light. Butted 14G (2 mm) J-Bend	3 Cruces	3 Cruces	271 mm	271 mm	1200 N	—	Por dentro	Por fuera	Por fuera Por dentro

BUJES	MODELO	SPACING (OLD)	EJE	TIPO DISCO	RADIOS	NÚCLEO	MECANISMO NÚCLEO	CABECILLAS	MODELO	MEDIDAS	ARANDELA CABECILLAS	PESO RUEDA	RUEDA	PESO	USO		
	DELANTERA 29"	DT SWISS 350 Hybrid Classic IS modelo desde MY2024	Boost 110 mm	Pasante 15 mm	6-Bolt	28 J-Bend	—		—	DELANTERA 29"	Sapim Brass Polyax		2x14 mm (14G)	No		DELANTERA 29"	985gr +/-5%
	TRASERA 29"	DT SWISS 350 Hybrid Classic IS modelo desde MY2024	Boost 148 mm	Pasante 12 mm	6-Bolt	32 J-Bend	Sram XD or Shimano MS		Ratchet 24	TRASERA 29"	Sapim Brass Polyax		2x14 mm (14G)	No		TRASERA 29"	1160gr +/-5%
	TRASERA 27.5"	DT SWISS 350 Hybrid Classic IS modelo desde MY2024	Boost 148 mm	Pasante 12 mm	6-Bolt	32 J-Bend	Sram XD or Shimano MS		Ratchet 24	TRASERA 27.5"	Sapim Brass Polyax		2x14 mm (14G)	No		TRASERA 27.5"	1085gr +/-5%

**ASTM Condición 5**  
(Ver manual de usuario)

Peso máximo del sistema  
(bicicleta + ciclista +  
equipación) =  
**135 kg.**

\*\* Para conocer la presión máxima de la llanta, consulta el manual de usuario o la calca en la propia rueda.

[Pincha en el modelo de buje o radios para acceder a la información de recambios](#)

MOUNTAIN CONTROL (MC)

MC32 TEAM POWER (MY2025)

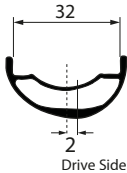
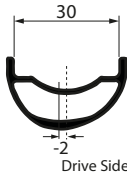
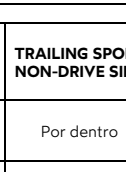
	MODELO	MATERIAL	TALLA	TIPO LLANTA	TIPO FRENO	TUBELESS	ANCHO INTERNO	OFFSET	AGUJEROS DIRECCIONALES	AGUJEROS RADIOS	ERD	ETRTO	UNIÓN	ANCHO CINTA TUBELESS	VÁLVULA	CUBIERTAS COMPATIBLES	PRESIÓN MÁXIMA	SECCIÓN	
LLANTAS	LLANTA DELANTERA 29"	MC36-F-29-28H	Aluminio AL6061	29"	Clincher Hookless	Disco	SI	32 mm	2 mm	SI	28	612,3 mm	622x32TSS	Sleeved	32 mm	44 mm	2.4"-2.8"	**	
	LLANTA TRASERA 29"	MC36-R-29-32H	Aluminio AL6061	29"	Clincher Hookless	Disco	SI	30 mm	-2 mm	SI	32	610,9 mm	622x30TSS	Sleeved	30 mm	44 mm 57 mm en Wild con imán en válvula	2.05"-2.8"	**	
	LLANTA TRASERA 27.5"	MC37-R-27-32H	Aluminio AL6061	27.5"	Clincher Hookless	Disco	SI	30 mm	-2 mm	SI	32	572,9 mm	584x30TSS	Sleeved	30 mm	44 mm 57 mm en Wild con imán en válvula	2.05"-2.8"	**	

	Nº RADIOS	MODELO	RADIADO DRIVE SIDE	RADIADO NON-DRIVE SIDE	LONGITUD RADIOS DRIVE SIDE	LONGITUD RADIOS NON-DRIVE SIDE	TENSIÓN MONTAJE DRIVE SIDE	TENSIÓN MONTAJE DISC SIDE	LEADING SPOKE DRIVE SIDE	TRAILING SPOKE DRIVE SIDE	LEADING SPOKE NON-DRIVE SIDE	TRAILING SPOKE NON-DRIVE SIDE
RADIOS	DELANTERA 29"	28	Sapim E-Light. Butted 14G (2 mm) J-Bend	3 Cruces	3 Cruces	301 mm	300 mm	—	1300 N	Por fuera	Por dentro	Por fuera Por dentro
	TRASERA 29"	32	Sapim E-Light. Butted 14G (2 mm) J-Bend	3 Cruces	3 Cruces	294 mm	295 mm	1300 N	—	Por dentro	Por fuera	Por fuera Por dentro
	TRASERA 27.5"	32	Sapim E-Light. Butted 14G (2 mm) J-Bend	3 Cruces	3 Cruces	275 mm	276 mm	1300 N	—	Por dentro	Por fuera	Por fuera Por dentro

BUJES	MODELO	SPACING (OLD)	EJE	TIPO DISCO	RADIOS	NÚCLEO	MECANISMO NÚCLEO	CABECILLAS	MODELO	MEDIDAS	ARANDELA CABECILLAS	PESO RUEDA	RUEDA	PESO	USO
	DELANTERA 29"	DT SWISS 350 Hybrid Classic IS modelo desde MY2024	Boost 110 mm	Pasante 15 mm	6-Bolt	28 J-Bend	—		—	DELANTERA 29"	Sapim Alloy Double Square		2x18 mm (14G)	No	
	TRASERA 29"	DT SWISS 350 Hybrid Classic IS modelo desde MY2024	Boost 148 mm	Pasante 12 mm	6-Bolt	32 J-Bend	Sram XD or Shimano MS	10 ° Ratchet 32	TRASERA 29"	Sapim Alloy Double Square	2x18 mm (14G)	No	TRASERA 29"	1180gr +/-5%	
	TRASERA 27.5"	DT SWISS 350 Hybrid Classic IS modelo desde MY2024	Boost 148 mm	Pasante 12 mm	6-Bolt	32 J-Bend	Sram XD or Shimano MS	10 ° Ratchet 32	TRASERA 27.5"	Sapim Alloy Double Square	2x18 mm (14G)	No	TRASERA 27.5"	1130gr +/-5%	

**ASTM Condición 5**  
(Ver manual de usuario)  
Peso máximo del sistema (bicicleta + ciclista + equipación) = **135 kg.**

\*\* Para conocer la presión máxima de la llanta, consulta el manual de usuario o la calca en la propia rueda.

[Pincha en el modelo de buje o radios para acceder a la información de recambios](#)

## MOUNTAIN CONTROL (MC)

## MC32 TEAM POWER (desde MY2026)

	MODELO	MATERIAL	TALLA	TIPO LLANTA	TIPO FRENO	TUBELESS	ANCHO INTERNO	OFFSET	AGUJEROS DIRECCIONALES	AGUJEROS RADIOS	ERD	ETRTO	UNIÓN	ANCHO CINTA TUBELESS	VÁLVULA	CUBIERTAS COMPATIBLES	PRESIÓN MÁXIMA	SECCIÓN	
LLANTAS	LLANTA DELANTERA 29"	MC36-F-29-28H	Aluminio AL6061	29"	Clincher Minihook	Disco	SI	32 mm	2 mm	SI	28	612,3 mm	622x32TSS	Sleeved	32 mm	44 mm	2.4"-2.8"	**	
	LLANTA TRASERA 29"	MC36-R-29-32H	Aluminio AL6061	29"	Clincher Minihook	Disco	SI	30 mm	-2 mm	SI	32	610,9 mm	622x30TSS	Sleeved	30 mm	44 mm en Wild con imán en válvula	2.05"-2.8"	**	
	LLANTA TRASERA 27.5"	MC37-R-27-32H	Aluminio AL6061	27.5"	Clincher Minihook	Disco	SI	30 mm	-2 mm	SI	32	572,9 mm	584x30TSS	Sleeved	30 mm	44 mm en Wild con imán en válvula	2.05"-2.8"	**	

	Nº RADIOS	MODELO	RADIADO DRIVE SIDE	RADIADO NON-DRIVE SIDE	LONGITUD RADIOS DRIVE SIDE	LONGITUD RADIOS NON-DRIVE SIDE	TENSIÓN MONTAJE DRIVE SIDE	TENSIÓN MONTAJE DISC SIDE	LEADING SPOKE DRIVE SIDE	TRAILING SPOKE DRIVE SIDE	LEADING SPOKE NON-DRIVE SIDE	TRAILING SPOKE NON-DRIVE SIDE	
RADIOS	DELANTERA 29"	28	Sapim E-Light. Butted 14G (2 mm) J-Bend	3 Cruces	3 Cruces	301 mm	300 mm	—	1300 N	Por fuera	Por dentro	Por fuera	Por dentro
	TRASERA 29"	32	Sapim E-Light. Butted 14G (2 mm) J-Bend	3 Cruces	3 Cruces	294 mm	295 mm	1300 N	—	Por dentro	Por fuera	Por fuera	Por dentro
	TRASERA 27.5"	32	Sapim E-Light. Butted 14G (2 mm) J-Bend	3 Cruces	3 Cruces	275 mm	276 mm	1300 N	—	Por dentro	Por fuera	Por fuera	Por dentro

	MODELO	SPACING (OLD)	EJE	TIPO DISCO	RADIOS	NÚCLEO	MECANISMO NÚCLEO
BUJES	DELANTERA 29"	DT SWISS 350 Hybrid Classic IS modelo desde MY2024	Boost 110 mm	Pasante 15 mm	6-Bolt	28 J-Bend	—
	TRASERA 29"	DT SWISS 350 Hybrid Classic IS modelo desde MY2024	Boost 148 mm	Pasante 12 mm	6-Bolt	32 J-Bend	Sram XD or Shimano MS
	TRASERA 27.5"	DT SWISS 350 Hybrid Classic IS modelo desde MY2024	Boost 148 mm	Pasante 12 mm	6-Bolt	32 J-Bend	Sram XD or Shimano MS

	MODELO	MEDIDAS	ARANDELA CABECILLAS	
CABECILLAS	DELANTERA 29"	Sapim Alloy Double Square	2x18 mm (14G)	No
	TRASERA 29"	Sapim Alloy Double Square	2x18 mm (14G)	No
	TRASERA 27.5"	Sapim Alloy Double Square	2x18 mm (14G)	No

	RUEDA	PESO
PESO RUEDA	DELANTERA 29"	1030gr +/-5%
	TRASERA 29"	1180gr +/-5%
	TRASERA 27.5"	1130gr +/-5%

USO
<p><b>ASTM Condición 5</b> (Ver manual de usuario)</p> <p>Peso máximo del sistema (bicicleta + ciclista + equipación) = <b>135 kg.</b></p>

\*\* Para conocer la presión máxima de la llanta, consulta el manual de usuario o la calca en la propia rueda.

[Pincha en el modelo de buje o radios para acceder a la información de recambios](#)

---

## MANTENIMIENTO DE RUEDAS OQUO

La información contenida en este manual está principalmente dirigida a distribuidores OQUO y usuarios con cierta experiencia en el mantenimiento de ruedas.

Si, como usuario, no dispones del conocimiento para llevar a cabo los procesos de mantenimiento descritos en este manual técnico o instalar los repuestos listados, lleva tus ruedas a un distribuidor OQUO para su reparación o mantenimiento.

Puedes encontrar la información de contacto de nuestros distribuidores en nuestra web:

[www.oquowheels.com](http://www.oquowheels.com)

### AVISO

Daños producidos por llevar a cabo los procesos de mantenimiento o reparaciones de manera inadecuada no están cubiertos por las condiciones de garantía.



La instalación de componentes, reparaciones o mantenimientos realizados de manera inadecuada pueden afectar a la integridad y funcionamiento de las ruedas, pudiendo ser causa de accidentes y lesiones graves, incluso la muerte.

### HERRAMIENTAS

Utiliza siempre las herramientas y productos adecuados para un mantenimiento o reparación concretos. Herramientas inadecuadas o en mal estado, o el uso de productos no específicos, pueden causar daños en los componentes que no están cubiertos por las condiciones de garantía.

Consulta la tabla de periodos de mantenimiento en este manual para conocer las comprobaciones y los periodos de mantenimiento de las ruedas y sus componentes.

Consulta la sección de mantenimiento de bujes de este manual para acceder a los manuales de mantenimiento de los fabricantes de bujes.

### TABLA DE PERIODOS DE MANTENIMIENTO

Consulta la siguiente tabla para conocer las comprobaciones y los periodos de mantenimiento de las ruedas y sus componentes.

### AVISO

Los periodos de mantenimiento de los componentes indicados a continuación son orientativos, y dependen en gran medida de factores como las condiciones meteorológicas de uso de la bicicleta (condiciones adversas reducen considerablemente la vida de los componentes y los tiempos de mantenimiento), limpieza de la bicicleta y sus componentes (componentes con suciedad acumulada se desgastan más rápidamente) y uso (un uso más exigente de la bicicleta requerirá periodos de mantenimiento más cortos).

Daños en los componentes derivados de la no observación de los periodos de mantenimiento no están cubiertos por las condiciones de garantía.

En este manual se especifican las herramientas a utilizar, o se referencian los manuales de mantenimiento de fabricantes de otros componentes en nuestras ruedas, donde se detallan las herramientas apropiadas.

COMPROBACIÓN	PERIODICIDAD		
	Antes de cada uso	Cada 2-3 usos	Cada 4-6 meses (40-60 horas)*/**
Limpiar las ruedas con agua con jabón o producto específico para limpieza de bicicletas. (no usar productos con base de amoníaco o disolventes)		✓	✓
Inspección de apriete y estado de los ejes pasantes o de cierre rápido	✓		
Inspección del estado de los discos de freno	✓		
Comprobación del apriete de los discos de freno			✓
Inspección de centricidad de la llanta	✓		✓
Inspección del estado de los neumáticos (cortes y desgaste)	✓		
Inspección manual de tensión y estado de radios	✓		
Inspección de manual giro y juego los rodamientos de los bujes y núcleo	✓		
Inspección de presión de las cubiertas y de pérdidas de aire	✓		
Inspección de daños en llanta, bujes y radios	✓		✓
Inspección y/o relleno del líquido sellante en cubiertas tubeless			✓
Limpieza de líquido sellante en llanta, cubierta y válvula			✓
Sustitución del fondo de llanta (estándar o tubeless) si es necesario			✓
Inspección de la tensión de radios con tensiómetro			✓
Inspección de la función de los bujes. servicio de rodamientos y del núcleo según las instrucciones del fabricante si es necesario			✓
Reemplazo de cámara en cubiertas estándar			✓

\*Estos tiempos pueden ser menores dependiendo del estilo y condiciones de uso.

\*\*Usuarios más pesados o que usen las ruedas cerca de sus límites de peso del sistema pueden requerir acortar los periodos de mantenimiento.

## HERRAMIENTAS PARA EL MANTENIMIENTO Y CONSTRUCCIÓN DE RUEDAS

Aquí se listan las herramientas necesarias para el mantenimiento correcto de ruedas OQUO en cuanto a construcción y centrado. Consulta las herramientas necesarias para el mantenimiento de bujes en la documentación del fabricante.

Esta lista está sujeta a cambios en las especificaciones de ruedas que pueden hacer necesario el uso de otras herramientas no mostradas aquí. Ante la duda, consulta con OQUO.

### 1. CENTRADOR DE RUEDAS DE DOBLE LADO

Siempre utiliza un centrador de doble lado de calidad para comprobar el centrado y la desviación de las ruedas. No realices estas comprobaciones y mantenimientos de la rueda con esta montada en la bicicleta. Los resultados podrían no ser precisos.

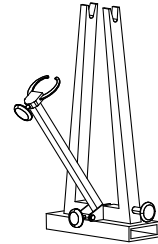

### 2. LLAVE DE RADIOS

**Externa:** Para el ajuste de las cabecillas desde la parte externa de la llanta. Para la mayoría de cabecillas.

**Interna:** Para el ajuste de las cabecillas desde la parte interna de la llanta (garganta). Las cabecillas Sapim Double Square pueden ser ajustadas desde el interior de la llanta al igual que desde el exterior con una llave de radios externa.

#### AVISO

Tanto si se usa una llave de radios interna o externa, ésta debe ser del tamaño correcto para las cabecillas para evitar dañar y/o redondear las cabecillas. Es útil disponer de llaves de radios de varios tamaños y probar en las cabecillas a ajustar para asegurarse de que la medida de la llave de radios es la correcta

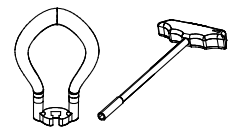

### 3. LLAVE DE RADIOS PLANOS

Usa una herramienta para sujetar los radios planos al ajustar la cabecilla y evitar la torsión del radio.

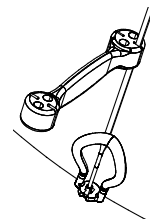

#### 4. TENSÍOMETRO

Siempre usa un tensiómetro de calidad y comprueba regularmente su calibración según las instrucciones del fabricante.

Sigue las instrucciones del fabricante para su correcto uso y para interpretar de manera adecuada la lectura de tensión dependiendo de las especificaciones de los radios.

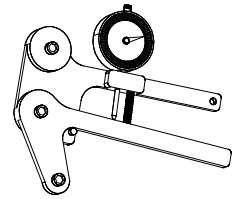

---

#### 5. APARAGUADOR

Siempre utiliza un aparaguador para comprobar la alineación de la llanta respecto a los extremos del buje que contactan con el interior del cuadro o la horquilla.

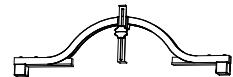

## AJUSTAR LA TENSIÓN DE LOS RADIOS

Comprueba regularmente la tensión y el estado de los radios.

Comprueba regularmente la desviación lateral (1), radial (2) y el aparaguado (3) de tus ruedas en un centrador de ruedas. Comprobaciones y ajustes de la rueda estando esta montada en la bicicleta pueden no ser precisas.

Si algún radio necesita ser ajustado, utiliza una llave de radios del tamaño correcto para ajustar la tensión de estos radios.

Consulta como destensar la rueda en la sección de construcción de ruedas de este manual. Comprueba los objetivos de desviación y tensión de las ruedas OQUO en la sección de Construcción de ruedas de este manual.

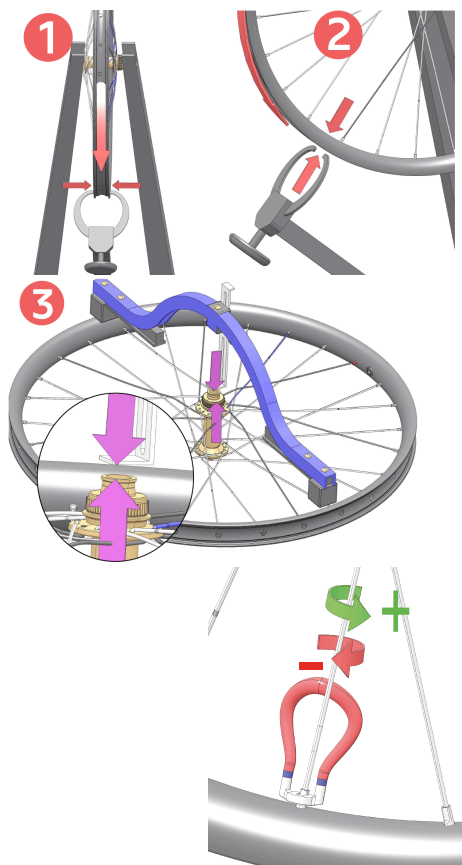

Utiliza una llave de radios planos para sujetar los radios planos y evitar la torsión del radio. También puede sujetar radios redondos con unos alicates lisos para evitar su torsión. Evita dañar los radios.

Al ajustar uno a varios radios, comprueba de nuevo la desviación lateral, radial y el aparaguado de la rueda. Si ajustas la tensión de 4 o más radios, destensa la rueda y comprueba su centrado.

## SUSTITUIR UN RADIO

Radios rotos, doblados o dañados deben ser sustituidos inmediatamente.

Para sustituir un radio, desmonta la cubierta y el fondo de llanta de la rueda.

Puede ser necesario desmontar el disco de freno, y en ruedas traseras el cassette, para sustituir un radio.



Usa una llave de radios para desmontar la cabecilla (1, 2)

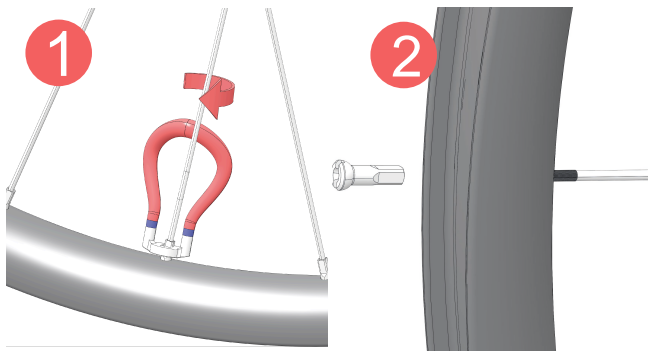

Desmonta el radio del buje (3). En el caso de que el radio esté partido, puedes extraer el radio roto junto a la cabecilla y desmontar el segmento del buje por separado (4).

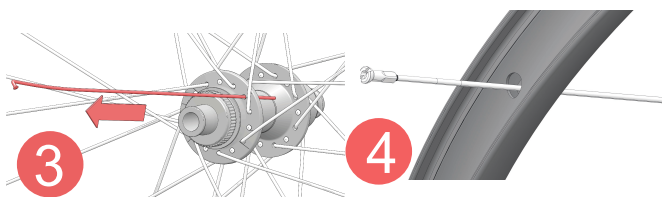

Instala el nuevo radio desde el lado del buje y en la posición del radio original.

Consulta la sección Patrones de radiado del capítulo Construcción de ruedas de este manual para una guía de la posición de los radios en los diferentes patrones de radiado. Consulta la tabla de especificaciones técnicas de este manual para conocer el modelo y longitud de los radios de tu modelo de rueda OQUO.

Utiliza un centrador de ruedas y las herramientas adecuadas para tensar el nuevo radio. Comprueba que tras la instalación la tensión de los radios es correcta y la desviación lateral y radial de la rueda y el aparaguado es el correcto.

Puede ser necesario ajustar varios radios además del radio sustituido. Si ajustas varios radios, destensa la rueda como se explica en la sección de Construcción de ruedas de este manual y comprueba que la alineación y tolerancias de desviación y tensión son correctas.

Vuelve a instalar el fondo de llanta, la cubierta y el disco de freno y cassette si fue necesario desmontarlos.

---

## MANTENIMIENTO DE BUJES

### MANTENIMIENTO DE BUJES

Consulta la tabla de especificaciones técnicas de ruedas OQUO de este manual para saber qué modelo de buje usa tu modelo de rueda.

La información contenida en este manual y los manuales de otros fabricantes aquí referenciados está principalmente dirigida a distribuidores OQUO o del fabricante del componente y a usuarios con cierta experiencia en el mantenimiento de ruedas.

Si, como usuario, no dispones del conocimiento para llevar a cabo los procesos de mantenimiento descritos en este manual técnico o instalar los repuestos listados, lleva tus ruedas a un distribuidor OQUO para su reparación o mantenimiento.

Puedes encontrar la información de contacto de nuestros distribuidores en nuestra web [www.oquowheels.com](http://www.oquowheels.com)

#### AVISO

---

Daños producidos por llevar a cabo los procesos de mantenimiento o reparaciones de manera inadecuada no están cubiertos por las condiciones de garantía.



---

La instalación de componentes, reparaciones o mantenimientos realizados de manera inadecuada pueden afectar a la integridad y funcionamiento de las ruedas, pudiendo ser causa de accidentes y lesiones graves, incluso la muerte.

### BUJES DT SWISS MTB & OQUO DT INSIDE

Consulta en la siguiente página los enlaces a los manuales de bujes DT Swiss MTB en la web del fabricante:

#### AVISO

---

Los bujes Oqu DT Inside tienen los mismos componentes que el buje DT Swiss equivalente (menos el cuerpo del buje), por lo que los procesos de servicio y mantenimiento son los mismos que en el buje DT Swiss equivalente.

MODELO BUJE	TIPO MANUAL/ NOMBRE	CONTENIDOS	LINK AL DOCUMENTO
Todos los bujes Oquo DT Inside y DT Swiss	Manual de usuario/ HUBS USER MANUAL ALL HUBS	<ul style="list-style-type: none"> <li>• Información general</li> <li>• Advertencias de uso</li> <li>• Montaje</li> <li>• Mantenimiento y cuidados</li> </ul>	<a href="https://www.dtswiss.com/pmt/00/00/00/00/00/00/10/00/00/00/86/2/MAN_HXWXXXXXX1610S_WEB_ZZ_001.pdf">https://www.dtswiss.com/pmt/00/00/00/00/00/00/10/00/00/00/86/2/MAN_HXWXXXXXX1610S_WEB_ZZ_001.pdf</a>
Bujes delanteros Oquo DT Inside y DT Swiss	Manual técnico/ FRONT HUBS TECHNICAL MANUAL	<ul style="list-style-type: none"> <li>• Desmontaje, limpieza y sustitución de los rodamientos y el eje</li> <li>• Herramientas, componentes y materiales necesarios</li> </ul>	<a href="https://d2a13k6araex7u.cloudfront.net/pmt/00/00/00/00/00/00/10/00/00/05/56/2/MAN_HXD10000005562S_WEB_EN_001.pdf">https://d2a13k6araex7u.cloudfront.net/pmt/00/00/00/00/00/00/10/00/00/05/56/2/MAN_HXD10000005562S_WEB_EN_001.pdf</a>
Buje trasero Oquo LTD DT Inside y DT Swiss 240	Manual técnico/ HUBS TECHNICAL MANUAL RATCHET EXP	<ul style="list-style-type: none"> <li>• Desmontaje, limpieza y sustitución de todas las partes del buje</li> <li>• Herramientas, componentes y materiales necesarios</li> </ul>	<a href="https://www.dtswiss.com/pmt/00/00/00/00/00/00/10/00/00/03/11/1/MAN_HXD10000003111S_WEB_EN_001.pdf">https://www.dtswiss.com/pmt/00/00/00/00/00/00/10/00/00/03/11/1/MAN_HXD10000003111S_WEB_EN_001.pdf</a>
	Manual de mantenimiento del núcleo RATCHET EXP FREEWHEEL MAINTENANCE	<ul style="list-style-type: none"> <li>• Desmontaje, limpieza y sustitución del sistema Ratchet EXP y del núcleo</li> <li>• Herramientas, componentes y materiales necesarios</li> </ul>	<a href="https://www.dtswiss.com/pmt/00/00/00/00/00/00/10/00/00/04/19/3/MAN_HXD10000004193S_XXX_EN_001.pdf">https://www.dtswiss.com/pmt/00/00/00/00/00/00/10/00/00/04/19/3/MAN_HXD10000004193S_XXX_EN_001.pdf</a>
	Manual de sustitución Ratchet EXP 36T a EXP 54T RATCHET EXP HUBS 36 TO 54 CONVERSION	<ul style="list-style-type: none"> <li>• Sustitución del sistema Ratchet EXP 36T por EXP 54T</li> <li>• Herramientas, componentes y materiales necesarios</li> </ul>	<a href="https://www.dtswiss.com/pmt/00/00/00/00/00/00/10/00/00/03/77/3/MAN_HXD10000003773S_WEB_EN_001.pdf">https://www.dtswiss.com/pmt/00/00/00/00/00/00/10/00/00/03/77/3/MAN_HXD10000003773S_WEB_EN_001.pdf</a>
Buje trasero Oquo LTD DT Inside y DT Swiss 350 DEG 72	Todo sobre el buje 350 DEG/ Página de Soporte de DT Swiss	<ul style="list-style-type: none"> <li>• Recambios</li> <li>• Manuales</li> <li>• Videos</li> </ul>	<a href="https://www.dtswiss.com/en/support/product-support?matnr=H350TDDRR32SA5051S">https://www.dtswiss.com/en/support/product-support?matnr=H350TDDRR32SA5051S</a>
	Manual técnico/ RATCHET DEG HUBS	<ul style="list-style-type: none"> <li>• Desmontaje, limpieza y sustitución de todas las partes del buje</li> <li>• Herramientas, componentes y materiales necesarios</li> </ul>	<a href="https://d2a13k6araex7u.cloudfront.net/pmt/00/00/00/00/00/00/10/00/00/05/10/4/MAN_HXD10000005104S_WEB_EN_001.pdf">https://d2a13k6araex7u.cloudfront.net/pmt/00/00/00/00/00/00/10/00/00/05/10/4/MAN_HXD10000005104S_WEB_EN_001.pdf</a>
	Video/ 350 DEG COMPLETE SERVICE	<ul style="list-style-type: none"> <li>• Desmontaje, limpieza y sustitución de todas las partes del buje</li> <li>• Herramientas, componentes y materiales necesarios</li> </ul>	<a href="https://www.youtube.com/watch?v=UMLquGPw2Jg">https://www.youtube.com/watch?v=UMLquGPw2Jg</a>
Buje trasero Oquo Team DT Inside y DT Swiss 350	Manual técnico HUBS TECHNICAL MANUAL RATCHET	<ul style="list-style-type: none"> <li>• Desmontaje, limpieza y sustitución de todas las partes del buje</li> <li>• Herramientas, componentes y materiales necesarios</li> </ul>	<a href="https://www.dtswiss.com/pmt/00/00/00/00/00/00/10/00/00/00/89/6/MAN_WXD10000000896S_WEB_EN_001.pdf">https://www.dtswiss.com/pmt/00/00/00/00/00/00/10/00/00/00/89/6/MAN_WXD10000000896S_WEB_EN_001.pdf</a>
Buje trasero DT Swiss 350 Hybrid	Manual técnico HUBS TECHNICAL MANUAL RATCHET	<ul style="list-style-type: none"> <li>• Desmontaje, limpieza y sustitución de todas las partes del buje</li> <li>• Herramientas, componentes y materiales necesarios</li> </ul>	<a href="https://www.dtswiss.com/pmt/00/00/00/00/00/00/10/00/00/00/89/6/MAN_WXD10000000896S_WEB_EN_001.pdf">https://www.dtswiss.com/pmt/00/00/00/00/00/00/10/00/00/00/89/6/MAN_WXD10000000896S_WEB_EN_001.pdf</a>
Buje trasero DT Swiss 370	Manual técnico HUBS TECHNICAL MANUAL RATCHET LN	<ul style="list-style-type: none"> <li>• Desmontaje, limpieza y sustitución de todas las partes del buje</li> <li>• Herramientas, componentes y materiales necesarios</li> </ul>	<a href="https://www.dtswiss.com/pmt/00/00/00/00/00/00/10/00/00/03/77/4/MAN_HXD10000003774S_WEB_EN_001.pdf">https://www.dtswiss.com/pmt/00/00/00/00/00/00/10/00/00/03/77/4/MAN_HXD10000003774S_WEB_EN_001.pdf</a>

## RECAMBIOS

### RECAMBIOS DE BUJES OQUO DT SWISS INSIDE

Consulta la tabla de especificaciones técnicas de ruedas OQUO para conocer el modelo de buje de tu rueda

#### BUJES DELANTEROS OQUO DT SWISS INSIDE

##### Oquo LTD DT Swiss 240 Inside Straight Pull 15x110 24H Centerlock

Consulta la tabla de especificaciones técnicas de ruedas OQUO para conocer el modelo de buje de tu rueda

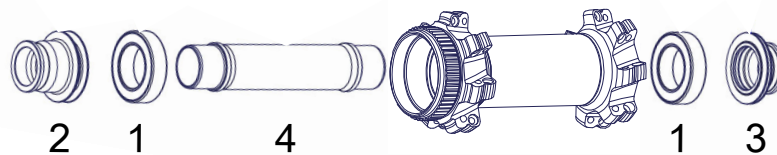

	DESCRIPCIÓN	CANTIDAD POR BUJE	Nº ART. DT DT SWISS	Nº ART. ORBEA
1	B.BEARING 1728 ESB/ESNB L	2	HSBXXX00N9115S	<a href="#">XB68</a>
2	FW ADAPT WP XXX/15 L BM DISC	1	HWAXXX00S2760S	<a href="#">XB69</a>
3	FW ADAPT WP XXX/15 R BM DISC	1	HWAXXX00S2761S	<a href="#">XB70</a>
4	FW AXLE AL 110 mm diam 17/64.3 mm	1	HRCXXX00N3296S	<a href="#">XB71</a>

	DESCRIPCIÓN	Nº ART. DT DT SWISS	Nº ART. ORBEA
<b>Compuesto de montaje</b>	DT Swiss universal grease 20 g	HXTXXX00NMG20S	<a href="#">XB72</a>
<b>Herramientas</b>	Installation cylinder diam 17 / 28mm x 40mm	HXTXXX00N9345S	<a href="#">XB73</a>
	Axle tool diam 17 mm	HXTXXX00N5067S	<a href="#">XB74</a>

Pincha en el número de artículo para comprar online. Los recambios de bujes están disponibles exclusivamente para distribuidores Orbea a través de Kide (acceso B2B)

## BUJES DELANTEROS OQUO DT SWISS INSIDE

### Oquo TEAM DT Swiss 350 Inside Straight Pull 15x110 28H Centerlock/6-bolt

Consulta la tabla de especificaciones técnicas de ruedas OQUO para conocer el modelo de buje de tu rueda

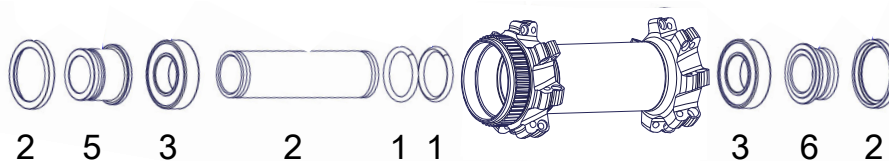

	DESCRIPCIÓN	CANTIDAD POR BUJE	Nº ART. DT SWISS	Nº ART. ORBEA
1	O-RING diam 18X2.5mm NBR 70 SHORE ISO3601	2	HSOXXX00X2164S	XC04
2	FW COVER FOR TA15 mm	2	HCD00100S4603S	XC05
3	B.BEARING 6902 ESB/ESNB L	2	HSBXXX00N2336S	XC06
4	SPACER diam 15mm x 67.2mm	1	HXD00000N6567C	XC07
5	FW ADAPT SP XXX/15 L B	1	HCA00100S7745S	XC08
6	FW ADAPT SP XXX/15 R B	1	HCA00100S7744S	XC09

	DESCRIPCIÓN	Nº ART. DT SWISS	Nº ART. ORBEA
<b>Compuesto de montaje</b>	DT Swiss universal grease 20 g	HXTXXX00NMG20S	XB72
<b>Herramientas</b>	Toolset 350 15mm	HWTXXX00N5290S	XC10
	Mounting tool	HXTXXX00N9793S	XC11

Pincha en el número de artículo para comprar online. Los recambios de bujes están disponibles exclusivamente para distribuidores Orbea a través de Kide (acceso B2B)

**BUJES DELANTEROS OQUO DT SWISS INSIDE****Oquo LTD DT Swiss 350 Inside J-bend 15x110 28H 6-bolt**

Consulta la tabla de especificaciones técnicas de ruedas OQUO para conocer el modelo de buje de tu rueda

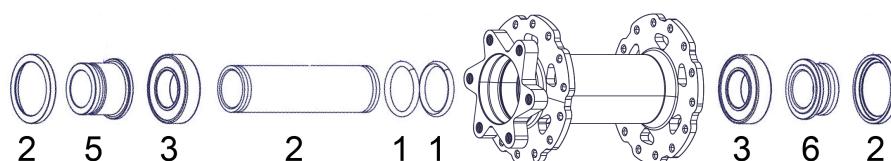

	DESCRIPCIÓN	CANTIDAD POR BUJE	Nº ART. DT SWISS	Nº ART. ORBEA
1	O-RING diam 18X2.5mm NBR 70 SHORE ISO3601	2	HSOXXX00X2164S	XC04
2	FW COVER FOR TA15 mm	2	HCD00100S4603S	XC05
3	B.BEARING 6902 ESB/ESNB L	2	HSBXXX00N2336S	XC06
4	SPACER diam 15mm x 67.2mm	1	HXD00000N6567C	XC07
5	FW ADAPT SP XXX/15 L B	1	HCA00100S7745S	XC08
6	FW ADAPT SP XXX/15 R B	1	HCA00100S7744S	XC09

	DESCRIPCIÓN	Nº ART. DT SWISS	Nº ART. ORBEA
<b>Compuesto de montaje</b>	DT Swiss universal grease 20 g	HXTXXX00NMG20S	XB72
<b>Herramientas</b>	Toolset 350 15mm	HWTXXX00N5290S	XC10
	Mounting tool	HXTXXX00N9793S	XC11

Pincha en el número de artículo para comprar online. Los recambios de bujes están disponibles exclusivamente para distribuidores Orbea a través de Kide (acceso B2B)

## BUJES TRASEROS OQUO DT SWISS INSIDE

### Oquo LTD DT Swiss 240 Inside Straight Pull 12x148 28H Centerlock

Consulta la tabla de especificaciones técnicas de ruedas OQUO para conocer el modelo de buje de tu rueda

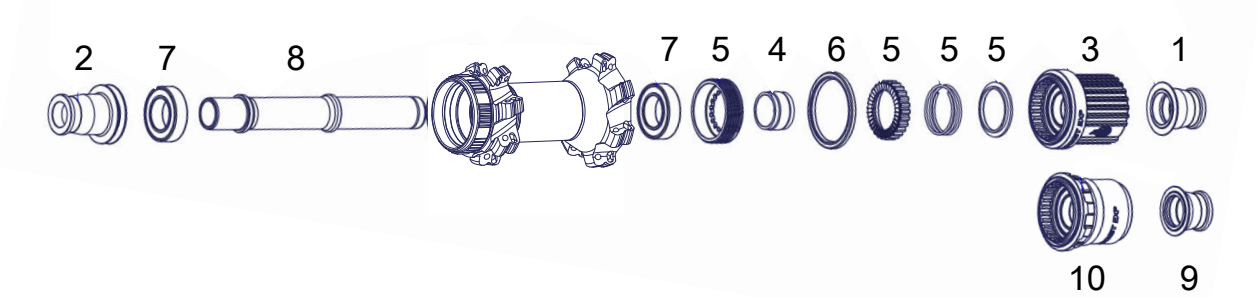

	DESCRIPCIÓN	CANTIDAD POR BUJE	Nº ART. DT SWISS	Nº ART. ORBEA
1	RW ADAPT WP XXX/12 R BM MS	1	HWAXXX00S2766S	<a href="#">XB87</a>
2	RW ADAPT WP XXX/12 L BM	1	HWAXXX00S2763S	<a href="#">XB88</a>
3	FB W MTB SHI MS EXP AL LI SL M	1	HWRABL00S4863S	<a href="#">XB89</a>
4	SPACER ALLOY 10.7 EXP	1	HRDXXX00N8242S	<a href="#">XB90</a>
5	SERVICE KIT RATCHET 36T EXP W/O TOOL	1	HWYXXX00N0042S	<a href="#">XB91</a>
6	SEAL HUB/ROTOR (diam 30x36x2.5 mm)	1	HSOXXX00N1031S	<a href="#">XB92</a>
7	B.BEARING 1526 ESB/ESNB L	2	HSBXXX00N3741S	<a href="#">XB93</a>
8	RW AXLE AL XXX mm diam 15/52.85 mm EXP	1	HCCXXX00S3303S	<a href="#">XB94</a>
9	RW ADAPT WP XXX/12 R BM SRAM XD	1	HWAXXX00S2767S	<a href="#">XB95</a>
10	FB W MTB SRA XD EXP AL ST SL M	1	HWRABL00S3830S	<a href="#">XB96</a>

	DESCRIPCIÓN	Nº ART. DT SWISS	Nº ART. ORBEA
<b>Compuesto de montaje</b>	DT Swiss universal grease 20 g	HXTXXX00NMG20S	<a href="#">XB72</a>
	DT Swiss special grease 20 g	HXT10032508S	<a href="#">XB97</a>
<b>Herramientas</b>	Installation cylinder 15x26x40 mm	HWTXXX00N5290S	<a href="#">XB98</a>
	Mounting/dismounting tool for the threaded ratchet	HXTXXX00N9793S	<a href="#">XB99</a>
	Mounting/dismounting tool ball bearing drive side	HWTXXX00N5290S	<a href="#">XC01</a>
	Installation tool for hub seal	HXTXXX00N9793S	<a href="#">XC02</a>

Pincha en el número de artículo para comprar online. Los recambios de bujes están disponibles exclusivamente para distribuidores Orbea a través de Kide (acceso B2B)

## BUJES TRASEROS OQUO DT SWISS INSIDE

### Oquo LTD DT Swiss 350 Inside Straight Pull 12x148 28/32H Centerlock/6-bolt

Consulta la tabla de especificaciones técnicas de ruedas OQUO para conocer el modelo de buje de tu rueda

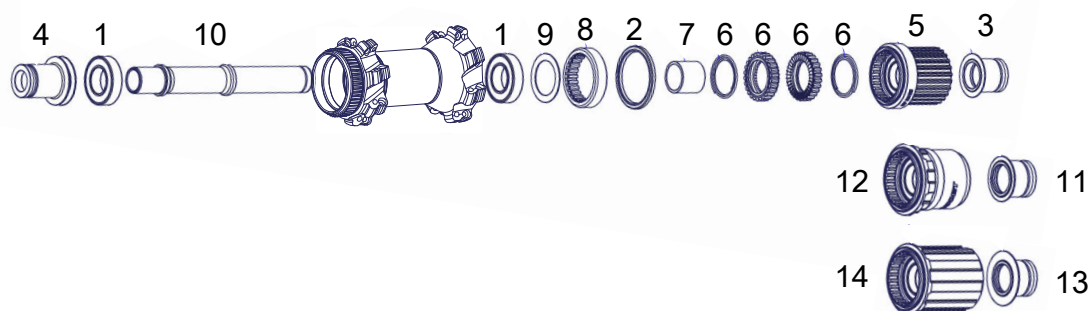

	DESCRIPCIÓN	CANTIDAD POR BUJE	Nº ART. DT SWISS	Nº ART. ORBEA
1	B.BEARING 6902 ESB/ESNB L	2	HSBXXX00N2336S	XC06
2	SEAL HUB/ROTOR (diam 30x36x2.5mm)	1	HSOXXX00N1031S	XB92
3	RW ADAPT WP XXX/12 R B MS	1	HWA00100S7912S	XC15
4	RW ADAPT WP XXX/12 L B	1	HWA00100S7841S	XC17
5	FB W MTB SHI MS RAT AL LI SL B	1	HWRABL00S2148S	XC19
6	SERVICE KIT RATCHET 36T SL	1	HWTXXX00NSK36S	XC20
7	SPACER ALLOY 15.4 mm BL	1	HCDXXX00S1077S	XC21
8	RING NUT STEEL M34X1 240	1	HXDXXX00N1131S	XC22
9	SHIM RING diam 28/20X0.5mm	1	HCDXXX00S1083S	XC23
10	RW AXLE AL 148mm diam 15/48.2mm	1	HCCXXX00S6450S	XC24
11	RW ADAPT WP XXX/12 R B SRAM XD	1	HWA00100S7513S	XC25
12	FB W MTB SRA XD RAT AL ST SL B	1	HWRACL00S3114S	XC26
13	RW ADAPT WP XXX/12 R B	1	HWA00100S7892S	XC27
14	FB W MTB SHI RAT AL LI SL B	1	HWRABL00S1239S	XC28

	DESCRIPCIÓN	Nº ART. DT SWISS	Nº ART. ORBEA
Compuesto de montaje	DT Swiss universal grease 20 g	HXTXXX00NMG20S	XB72
	DT Swiss special grease 20 g	HXT10032508S	XB97
Herramientas	Installation cylinder 15x26x40 mm	HWTXXX00N5290S	XB98
	Installation tool for hub seal	HXTXXX00N1000S	XC02
	Tool for ring nut	HXTXXX00N5027S	XC32

Pincha en el número de artículo para comprar online. Los recambios de bujes están disponibles exclusivamente para distribuidores Orbea a través de Kide (acceso B2B)

## BUJES TRASEROS OQUO DT SWISS INSIDE

### Oquo LTD DT Swiss Inside 350 DEG J-bend 12x148 32H 6-bolt

Consulta la tabla de especificaciones técnicas de ruedas OQUO para conocer el modelo de buje de tu rueda

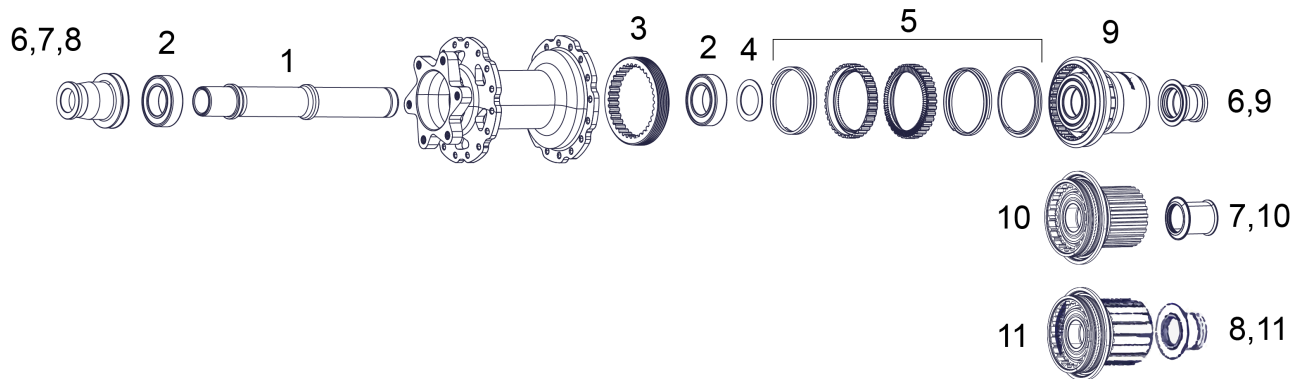

	DESCRIPCIÓN	CANTIDAD POR BUJE	Nº ART. DT SWISS	Nº ART. ORBEA
1	RW AXLE AL 148mm diam 15/48.2mm	1	HCCXXX00S6450S	<a href="#">XC24</a>
2	B.BEARING 6902 ESB/ESNB L	2	HSBXXX00N2336S	<a href="#">XC06</a>
3	RING NUT ST M45X2-2MM DEG	1	HXDXXX00N9037S	<a href="#">XJ88</a>
4	SPACER ALLOY 2.95mm N	1	HCD14200N9313S	<a href="#">XJ89</a>
5	SERVICE KIT RATCHET 72T DEG	1	HWYXXX00N6599S	<a href="#">XJ90</a>
6	RW ADAPT KIT 142/Ø12 240 SRAM XD (ONLY CAPS)	1	HWGXXX00S3188S	<a href="#">X649</a>
7	RW ADAPT KIT XXX/12 B MS (ONLY CAPS)	1	HWGXXX00S5643S	<a href="#">X647</a>
8	CONVERSION KIT X12 HG (ONLY CAPS)	1	HWGXXX0002193C	<a href="#">X648</a>
9	FB K MTB SRA XD DEG 12/148 AL ST SL B	1	HWYABL00S2779S	<a href="#">XJ91</a>
10	FB K MTB SHI MS DEG 12/148 AL ST SL B	1	HWYABL00S2787S	<a href="#">XJ92</a>
11	FB K MTB SHI DEG 12/148 AL ST SL B	1	HWYABL00S2786S	<a href="#">XJ93</a>

	DESCRIPCIÓN	Nº ART. DT SWISS	Nº ART. ORBEA
<b>Compuesto de montaje</b>	DT Swiss universal grease 20 g	HXTXXX00NMG20S	<a href="#">XB72</a>
	DT Swiss special grease 20 g	HXT10032508S	<a href="#">XB97</a>
<b>Herramientas</b>	Installation cylinder 15x26x40 mm	HWTXXX00N5290S	<a href="#">XB98</a>
	Installation cylinder diam 15 / 28 x 35 mm	HXTXXX00N5024S	<a href="#">XC02</a>
	tool for ring nut DEG	HXTXXX00N2612S	<a href="#">XJ94</a>

Pincha en el número de artículo para comprar online. Los recambios de bujes están disponibles exclusivamente para distribuidores Orbea a través de Kide (acceso B2B)

**RECAMBIOS DE BUJES DT SWISS**

Consulta la tabla de especificaciones técnicas de ruedas OQUO para conocer el modelo de buje de tu rueda

**BUJES DELANTEROS DT SWISS****DT Swiss 240 J-bend 15x110 24/28H Centerlock/6-bolt**

Consulta la tabla de especificaciones técnicas de ruedas OQUO para conocer el modelo de buje de tu rueda

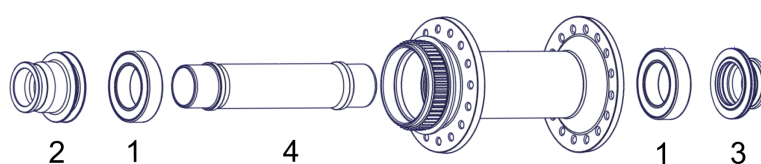

	DESCRIPCIÓN	CANTIDAD POR BUJE	Nº ART. DT DT SWISS	Nº ART. ORBEA
1	B.BEARING 1728 ESB/ESNB L	2	HSBXXX00N9115S	<a href="#">XB68</a>
2	FW ADAPT WP XXX/15 L BM DISC	1	HWAXXX00S2760S	<a href="#">XB69</a>
3	FW ADAPT WP XXX/15 R BM DISC	1	HWAXXX00S2761S	<a href="#">XB70</a>
4	FW AXLE AL 110 mm diam 17/64.3 mm	1	HRCXXX00N3296S	<a href="#">XB71</a>

	DESCRIPCIÓN	Nº ART. DT SWISS	Nº ART. ORBEA
<b>Compuesto de montaje</b>	DT Swiss universal grease 20g	HXTXXX00NMG20S	<a href="#">XB72</a>
<b>Herramientas</b>	Installation cylinder diam 17 / 28mm x 40mm	HXTXXX00N9345S	<a href="#">XB73</a>
	Axle tool diam 17 mm	HXTXXX00N5067S	<a href="#">XB74</a>

Pincha en el número de artículo para comprar online. Los recambios de bujes están disponibles exclusivamente para distribuidores Orbea a través de Kide (acceso B2B)

## BUJES DELANTEROS DT SWISS

### DT Swiss 350 J-bend 15x110 28H Centerlock/6-bolt

Consulta la tabla de especificaciones técnicas de ruedas OQUO para conocer el modelo de buje de tu rueda

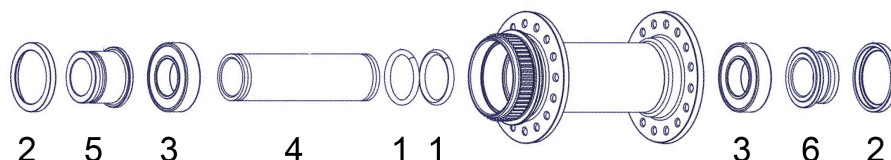

	DESCRIPCIÓN	CANTIDAD POR BUJE	Nº ART. DT SWISS	Nº ART. ORBEA
1	O-RING diam 18X2.5mm NBR 70 SHORE ISO3601	2	HSOXXX00X2164S	XC04
2	FW COVER FOR TA15mm	2	HCD00100S4603S	XC05
3	B.BEARING 6902 ESB/ESNB L	2	HSBXXX00N2336S	XC06
4	SPACER diam 15mm x 67.2mm	1	HXD00000N6567C	XC07
5	FW ADAPT SP XXX/15 L B	1	HCA00100S7745S	XC08
6	FW ADAPT SP XXX/15 R B	1	HCA00100S7744S	XC09

	DESCRIPCIÓN	Nº ART. DT SWISS	Nº ART. ORBEA
<b>Compuesto de montaje</b>	DT Swiss universal grease 20g	HXTXXX00NMG20S	XB72
<b>Herramientas</b>	Toolset 350 15mm	HWTXXX00N5290S	XC10
	Mounting tool	HXTXXX00N9793S	XC11

Pincha en el número de artículo para comprar online. Los recambios de bujes están disponibles exclusivamente para distribuidores Orbea a través de Kide (acceso B2B)

## BUJES DELANTEROS DT SWISS

### DT Swiss 350 J-bend 20x110 28H 6-bolt

Consulta la tabla de especificaciones técnicas de ruedas OQUO para conocer el modelo de buje de tu rueda

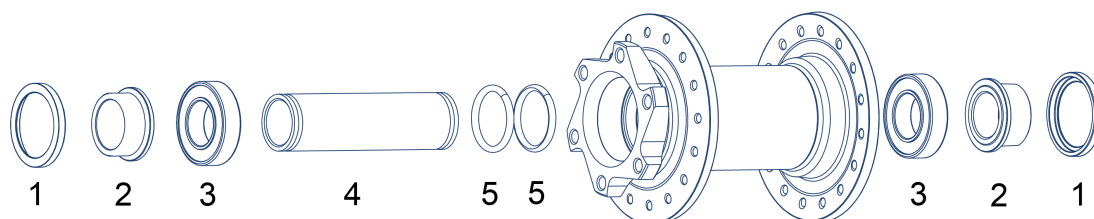

	DESCRIPCIÓN	CANTIDAD POR BUJE	Nº ART. DT SWISS	Nº ART. ORBEA
1	FW COVER FOR TA20mm	2	HCDXXX00S1461S	XJ95
2	FW ADAPT SP 110X DBIS TA20 B	2	HCAXXX00S6824S	XJ96
3	B.BEARING 6904 ESB/ESNB L	2	HSBXXX00N1414S	XJ97
4	FW SPACER 65.1x25MM	1	HXDXXX00N6823S	XJ98
5	O-RING diam 18X2.5mm NBR 70 SHORE ISO3601	2	HSOXXX00X2164S	XC04

	DESCRIPCIÓN	Nº ART. DT SWISS	Nº ART. ORBEA
<b>Compuesto de montaje</b>	DT Swiss universal grease 20g	HXTXXX00NMG20S	XB72
<b>Herramientas</b>	Toolset 350 20mm	HWTXXX00N5292S	—
	Mounting tool	HXTXXX00N9793S	XC11

Pincha en el número de artículo para comprar online. Los recambios de bujes están disponibles exclusivamente para distribuidores Orbea a través de Kide (acceso B2B)

## BUJES DELANTEROS DT SWISS

### DT Swiss 370 J-bend 15x110 28H 6-bolt

Consulta la tabla de especificaciones técnicas de ruedas OQUO para conocer el modelo de buje de tu rueda

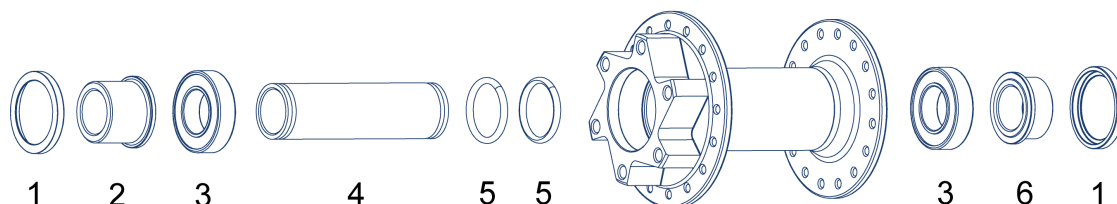

	DESCRIPCIÓN	CANTIDAD POR BUJE	Nº ART. DT SWISS	Nº ART. ORBEA
1	FW COVER FOR TA15MM	2	HCD00100S4603S	<a href="#">XC05</a>
2	FW ADAPT SP 100L DBCL SA15 S	1	HCA00100S4601S	<a href="#">XC48</a>
3	B.BEARING 6902 ESB/ESNB L	2	HSBXXX00N2336S	<a href="#">XC06</a>
4	SPACER Ø15MM x 67.2MM	1	HXD00000N6567C	<a href="#">XC07</a>
5	O-RING Ø18X2.5MM NBR 70 SHORE ISO3601	2	HSOXXX00X2164S	<a href="#">XC04</a>
6	FW ADAPT SP 100R DBCL SA15 S	1	HCA00100S4602S	<a href="#">XC47</a>

	DESCRIPCIÓN	Nº ART. DT SWISS	Nº ART. ORBEA
<b>Compuesto de montaje</b>	DT Swiss universal grease 20g	HXTXXX00NMG20S	<a href="#">XB72</a>
<b>Herramientas</b>	Toolset 350 15mm	HWTXXX00N5290S	<a href="#">XC10</a>
	Mounting tool	HXTXXX00N9793S	<a href="#">XC11</a>

Pincha en el número de artículo para comprar online. Los recambios de bujes están disponibles exclusivamente para distribuidores Orbea a través de Kide (acceso B2B)

**BUJES DELANTEROS DT SWISS****DT Swiss 350 Hybrid J-bend 15x110 32H 6-bolt (hasta MY2023)**

Consulta la tabla de especificaciones técnicas de ruedas OQUO para conocer el modelo de buje de tu rueda

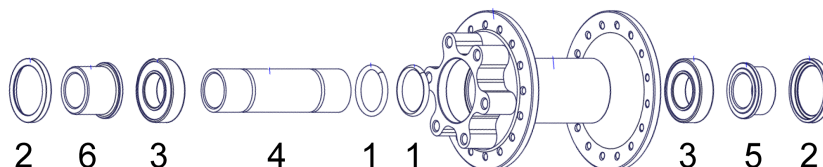

	DESCRIPCIÓN	CANTIDAD POR BUJE	Nº ART. DT SWISS	Nº ART. ORBEA
1	O-RING diam 18X2.5mm NBR 70 SHORE ISO3601	2	HSOXXX00X2164S	XC04
2	FW COVER FOR TA15mm	2	HCD00100S4603S	XC05
3	B.BEARING 6902 ESB/ESNB L	2	HSBXXX00N2336S	XC06
4	SPACER diam 15mm x 67.2M	1	HXD00000N6449S	XC46
5	FW ADAPT SP 100R DBCL SA15 S	1	HCA00100S4602S	XC47
6	FW ADAPT SP 100L DBCL SA15 S	1	HCA00100S4601S	XC48

	DESCRIPCIÓN	Nº ART. DT SWISS	Nº ART. ORBEA
<b>Compuesto de montaje</b>	DT Swiss universal grease 20g	HXTXXX00NMG20S	XB72
<b>Herramientas</b>	Toolset 350 15mm	HWTXXX00N5290S	XC10
	Mounting tool	HXTXXX00N9793S	XC11

Pincha en el número de artículo para comprar online. Los recambios de bujes están disponibles exclusivamente para distribuidores Orbea a través de Kide (acceso B2B)

## BUJES DELANTEROS DT SWISS

### DT Swiss 350 Hybrid J-bend 15x110 28H 6-bolt (desde MY2024)

Consulta la tabla de especificaciones técnicas de ruedas OQUO para conocer el modelo de buje de tu rueda

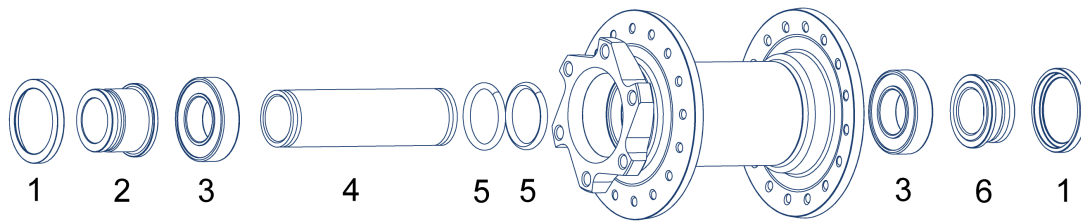

	DESCRIPCIÓN	CANTIDAD POR BUJE	Nº ART. DT SWISS	Nº ART. ORBEA
1	FW COVER FOR TA15mm	2	HCD00100S4603S	XC05
2	FW ADAPT SP XXX/15 L B	1	HCA00100S7745S	XC08
3	B.BEARING 6902 ESB/ESNB L	2	HSBXXX00N2336S	XC06
4	SPACER Ø15MM x 67.2MM	1	HXD00000N6567C	XC07
5	O-RING diam 18X2.5mm NBR 70 SHORE ISO3601	2	HSOXXX00X2164S	XC04
6	FW ADAPT SP XXX/15 R B	1	HCA00100S7744S	XC09

	DESCRIPCIÓN	Nº ART. DT SWISS	Nº ART. ORBEA
<b>Compuesto de montaje</b>	DT Swiss universal grease 20g	HXTXXX00NMG20S	XB72
<b>Herramientas</b>	Toolset 350 15mm	HWTXXX00N5290S	XC10
	Mounting tool	HXTXXX00N9793S	XC11

Pincha en el número de artículo para comprar online. Los recambios de bujes están disponibles exclusivamente para distribuidores Orbea a través de Kide (acceso B2B)

## BUJES TRASEROS DT SWISS

### DT Swiss 240 J-bend 12x148 28H Centerlock

Consulta la tabla de especificaciones técnicas de ruedas OQUO para conocer el modelo de buje de tu rueda

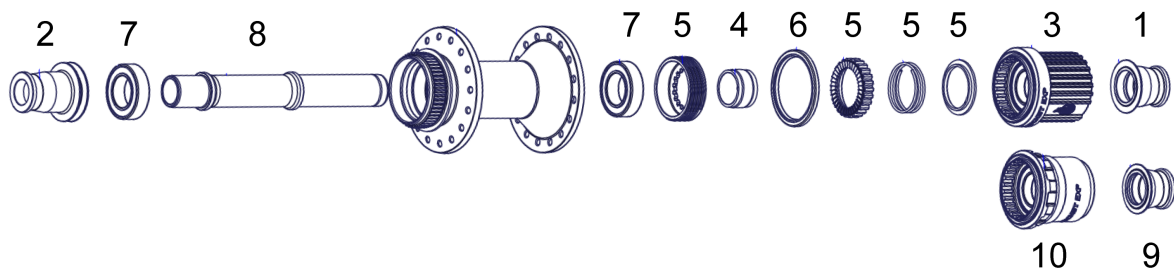

	DESCRIPCIÓN	CANTIDAD POR BUJE	Nº ART. DT SWISS	Nº ART. ORBEA
1	RW ADAPT WP XXX/12 R BM MS	1	HWAXXX00S2766S	<a href="#">XB87</a>
2	RW ADAPT WP XXX/12 L BM	1	HWAXXX00S2763S	<a href="#">XB88</a>
3	FB W MTB SHI MS EXP AL LI SL M	1	HWRABL00S4863S	<a href="#">XB89</a>
4	SPACER ALLOY 10.7 EXP	1	HRDXXX00N8242S	<a href="#">XB90</a>
5	SERVICE KIT RATCHET 36T EXP W/O TOOL	1	HWYXXX00N0042S	<a href="#">XB91</a>
6	SEAL HUB/ROTOR (diam 30x36x2.5 mm)	1	HSOXXX00N1031S	<a href="#">XB92</a>
7	B.BEARING 1526 ESB/ESNB L	2	HSBXXX00N3741S	<a href="#">XB93</a>
8	RW AXLE AL XXX mm diam 15/52.85 mm EXP	1	HCCXXX00S3303S	<a href="#">XB94</a>
9	RW ADAPT WP XXX/12 R BM SRAM XD	1	HWAXXX00S2767S	<a href="#">XB95</a>
10	FB W MTB SRA XD EXP AL ST SL M	1	HWRABL00S3830S	<a href="#">XB96</a>

	DESCRIPCIÓN	Nº ART. DT SWISS	Nº ART. ORBEA
<b>Compuesto de montaje</b>	DT Swiss universal grease 20g	HXTXXX00NMG20S	<a href="#">XB72</a>
	DT Swiss special grease 20 g	HXT10032508S	<a href="#">XB97</a>
<b>Herramientas</b>	Installation cylinder 15x26x40 mm	HWTXXX00N5290S	<a href="#">XB98</a>
	Mounting/dismounting tool for the threaded ratchet	HXTXXX00N9793S	<a href="#">XB99</a>
	Mounting/dismounting tool ball bearing drive side	HWTXXX00N5290S	<a href="#">XC01</a>
	Installation tool for hub seal	HXTXXX00N9793S	<a href="#">XC02</a>

Pincha en el número de artículo para comprar online. Los recambios de bujes están disponibles exclusivamente para distribuidores Orbea a través de Kide (acceso B2B)

## BUJES TRASEROS DT SWISS

### DT Swiss 350 J-bend 12x148 28/32H Centerlock/6-bolt

Consulta la tabla de especificaciones técnicas de ruedas OQUO para conocer el modelo de buje de tu rueda

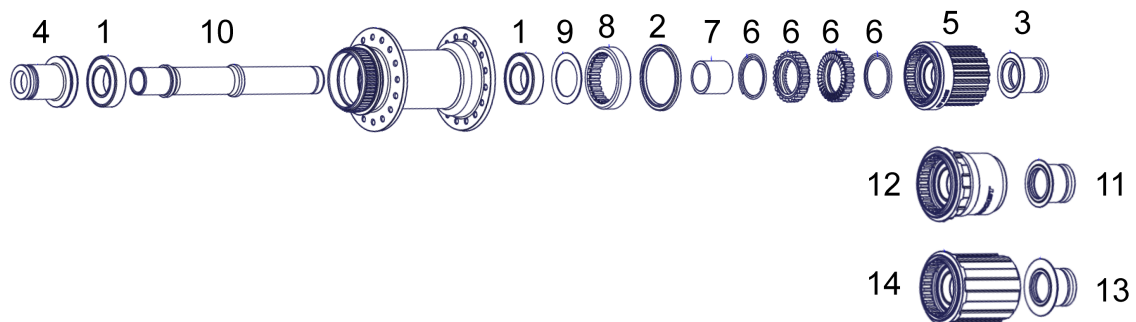

	DESCRIPCIÓN	CANTIDAD POR BUJE	Nº ART. DT SWISS	Nº ART. ORBEA
1	B.BEARING 6902 ESB/ESNB L	2	HSBXXX00N2336S	XC06
2	SEAL HUB/ROTOR diam 30x36x2.5mm)	1	HSOXXX00N1031S	XB92
3	RW ADAPT WP XXX/12 R B MS	1	HWA00100S7912S	XC15
4	RW ADAPT WP XXX/12 L B	1	HWA00100S7841S	XC17
5	FB W MTB SHI MS RAT AL LI SL B	1	HWRABL00S2148S	XC19
6	SERVICE KIT RATCHET 36T SL	1	HWTXXX00NSK36S	XC20
7	SPACER ALLOY 15,4mm BL	1	HCDXXX00S1077S	XC21
8	RING NUT STEEL M34X1 240	1	HXDXXX00N1131S	XC22
9	SHIM RING diam 28/20X0.5mm	1	HCDXXX00S1083S	XC23
10	RW AXLE AL 148mm diam 15/48.2mm	1	HCCXXX00S6450S	XC24
11	RW ADAPT WP XXX/12 R B SRAM XD	1	HWA00100S7513S	XC25
12	FB W MTB SRA XD RAT AL ST SL B	1	HWRAL00S3114S	XC26
13	RW ADAPT WP XXX/12 R B	1	HWA00100S7892S	XC27
14	FB W MTB SHI RAT AL LI SL B	1	HWRABL00S1239S	XC28

	DESCRIPCIÓN	Nº ART. DT SWISS	Nº ART. ORBEA
Compuesto de montaje	DT Swiss universal grease 20g	HXTXXX00NMG20S	XB72
	DT Swiss special grease 20 g	HXT10032508S	XB97
Herramientas	Installation cylinder 15x26x40 mm	HWTXXX00N5290S	XB98
	Installation tool for hub seal	HXTXXX00N1000S	XC02
	Tool for ring nut	HXTXXX00N5027S	XC32

Pincha en el número de artículo para comprar online. Los recambios de bujes están disponibles exclusivamente para distribuidores Orbea a través de Kide (acceso B2B)

## BUJES TRASEROS DT SWISS

### DT Swiss 370 J-bend 12x148 28H 6-bolt

Consulta la tabla de especificaciones técnicas de ruedas OQUO para conocer el modelo de buje de tu rueda

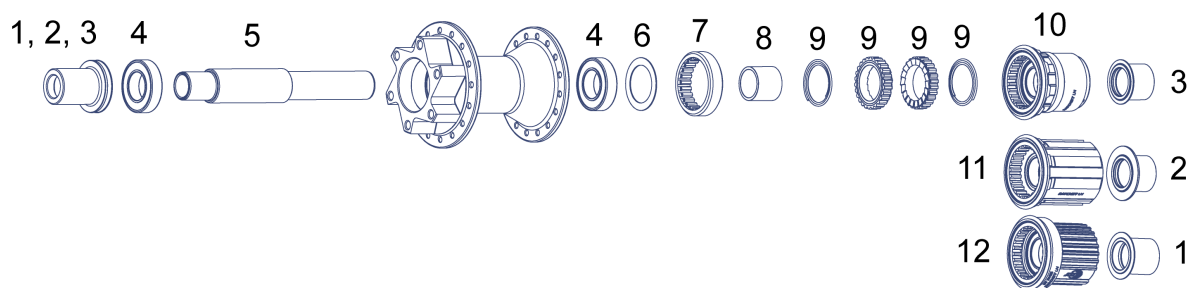

	DESCRIPCIÓN	CANTIDAD POR BUJE	Nº ART. DT SWISS	Nº ART. ORBEA
1	RW ADAPT KIT XXX/12 B MS	1	HWGXXX00S5643S	X647
2	CONVERSION KIT X12 HG	2	HWGXXX0002193C	X648
3	RW ADAPT KIT 142/Ø12 240 SRAM XD	1	HWGXXX00S3188S	X649
4	B.BEARING 6902 ESB/ESNB M	1	HSBXXX00N3221S	XC06
5	RW AXLE AL 148mm diam 15/48.2mm	1	HCCXXX00S6450S	XC24
6	SHIM RING diam 28/20X0.5mm	1	HCDXXX00S1083S	XC23
7	RING NUT STEEL M34X1 240	2	HXDXXX00N1131S	XC22
8	SPACER ALLOY 15.4 (ROTOR S)	2	HRDXXX00N4636S	XC35
9	SERVICE KIT H240/240S/FR/440	1	HWTXXX00NSK24S	X650
10	FB K MTB SRA XD LN 12/142/48 AL ST SM B	1	HWYABM00S3766S	X651
11	FB K MTB SHI LN 12/142/48 AF ST SM B	1	HWYABM00S3764S	X653
12	FB K MTB SHI MS LN 12/142/48 AL LI SM B	1	HWYABM00S3765S	X652

	DESCRIPCIÓN	Nº ART. DT SWISS	Nº ART. ORBEA
Compuesto de montaje	DT Swiss universal grease 20g	HXTXXX00NMG20S	XB72
	DT Swiss special grease 20 g	HXT10032508S	XB97
Herramientas	Installation cylinder 15x26x40 mm	HWTXXX00N5290S	XB98
	Installation tool for hub seal	HXTXXX00N1000S	XC02
	Tool for ring nut	HXTXXX00N5027S	XC32

Pincha en el número de artículo para comprar online. Los recambios de bujes están disponibles exclusivamente para distribuidores Orbea a través de Kide (acceso B2B)

## BUJES TRASEROS DT SWISS

### DT Swiss 350 Hybrid J-bend 12x148 32H 6-bolt (hasta MY2023)

Consulta la tabla de especificaciones técnicas de ruedas OQUO para conocer el modelo de buje de tu rueda

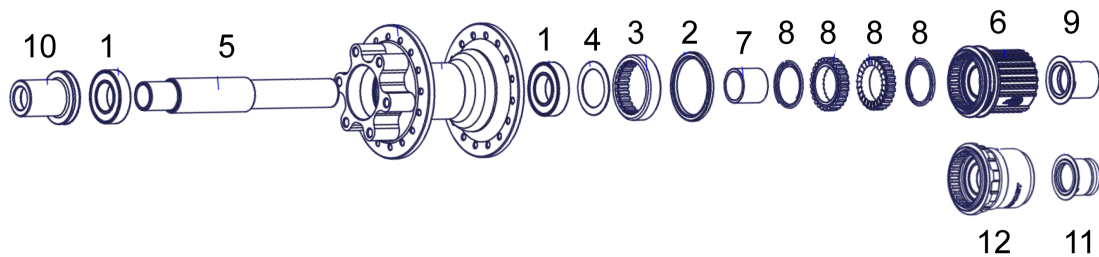

	DESCRIPCIÓN	CANTIDAD POR BUJE	Nº ART. DT SWISS	Nº ART. ORBEA
1	B.BEARING 6902 ESB/ESNB L	2	HSBXXX00N2336S	<a href="#">XC06</a>
2	SEAL HUB/ROTOR (diam 30x36x2.5 mm)	1	HSOXXX00N1031S	<a href="#">XB92</a>
3	RING NUT STEEL M34X1 240	1	HDXXXX00N1131S	<a href="#">XC22</a>
4	SHIM RING diam 28/20X0.5 mm	1	HCDXXX00S1083S	<a href="#">XC23</a>
5	RW AXLE AL 148 mm diam 15/48.2 mm	1	HCCXXX00S6450S	<a href="#">XC24</a>
6	FB W MHY SHI MS RAT ST ST SL B	1	HWRABL00S0758S	<a href="#">XC34</a>
7	SPACER ALLOY 15.4 (ROTOR S)	1	HRDXXX00N4636S	<a href="#">XC35</a>
8	SERVICE KIT RATCHET 24T	1	HWTXXX00NSKTFS	<a href="#">XC36</a>
9	RW ADAPT WP XXXR TA12 B MS	1	HWAXXX00S0491S	<a href="#">XC37</a>
10	RW ADAPT WP 142L DBIS SA12 S	1	HWA00100S2193C	<a href="#">XC38</a>
11	RW ADAPT WP XXXR TA12 B SRAM XD	1	HWAXXX00S3188S	<a href="#">XC39</a>
12	FB W MHY SRA XD RAT ST ST SL B	1	HWRAXL00S3224S	<a href="#">XC40</a>

	DESCRIPCIÓN	Nº ART. DT SWISS	Nº ART. ORBEA
<b>Compuesto de montaje</b>	DT Swiss universal grease 20g	HXTXXX00NMG20S	<a href="#">XB72</a>
	DT Swiss special grease 20 g	HXT10032508S	<a href="#">XB97</a>
<b>Herramientas</b>	Installation tool for hub seal	HXTXXX00N1000S	<a href="#">XC02</a>
	Tool for ring nut	HXTXXX00N5027S	<a href="#">XC32</a>
	Installation cylinder diam 15 / 28 x 35 mm	HXTXXX00N5024S	<a href="#">XC41</a>

Pincha en el número de artículo para comprar online. Los recambios de bujes están disponibles exclusivamente para distribuidores Orbea a través de Kide (acceso B2B)

## BUJES TRASEROS DT SWISS

### DT Swiss 350 Hybrid J-bend 12x148 32H 6-bolt (desde MY2024)

Consulta la tabla de especificaciones técnicas de ruedas OQUO para conocer el modelo de buje de tu rueda

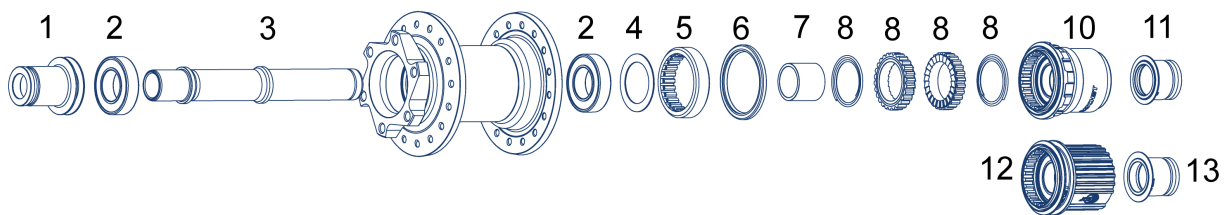

	DESCRIPCIÓN	CANTIDAD POR BUJE	Nº ART. DT SWISS	Nº ART. ORBEA
1	RW ADAPT WP XXX/12 L B	1	HWA00100S7841S	XC17
2	B.BEARING 6902 ESB/ESNB L	2	HSBXXX00N2336S	XC06
3	RW AXLE AL 148MM Ø15/48.2MM	1	HCCXXX00S6450S	XC24
4	SHIM RING Ø28/20X0.5MM	1	HCDXXX00S1083S	XC23
5	RING NUT STEEL M34X1 240	1	HXDXXX00N1131S	XC22
6	SEAL HUB/ROTOR (Ø30x36x2.5mm)	1	HSOXXX00N1031S	XB92
7	SPACER ALLOY 15,4MM BL	1	HCDXXX00S1077S	XC21
8	SERVICE KIT RATCHET 24T	1	HWTXXX00NSKTFS	XC36
10	FB W MHY SRA XD RAT ST ST SL B	1	HWRAXL00S3224S	XC40
11	RW ADAPT WP XXX/12 R B SRAM XD	1	HWA00100S7513S	XC25
12	FB W MHY SHI MS RAT ST ST SL B	1	HWRABL00S3226S	XC34
13	RW ADAPT WP XXX/12 R B MS	1	HWA00100S7912S	XC15

	DESCRIPCIÓN	Nº ART. DT SWISS	Nº ART. ORBEA
<b>Compuesto de montaje</b>	DT Swiss universal grease 20g	HXTXXX00NMG20S	XB72
	DT Swiss special grease 20 g	HXT10032508S	XB97
<b>Herramientas</b>	Installation tool for hub seal	HXTXXX00N1000S	XC02
	Tool for ring nut	HXTXXX00N5027S	XC32
	Installation cylinder diam 15 / 28 x 35 mm	HXTXXX00N5024S	XC41

Pincha en el número de artículo para comprar online. Los recambios de bujes están disponibles exclusivamente para distribuidores Orbea a través de Kide (acceso B2B)

## RADIO. KITS DE RADIOS RUEDAS OQUO

## MOUNTAIN PERFORMANCE (MP)

MODELO RUEDA	DELANTERA / TRASERA	BUJE	DESCRIPCIÓN RECAMBIO	INCLUYE	CANT.	COD. ART. ORBEA
MP30 LTD V1 hasta MY2024	DELANTERA 29" 24H	DT SWISS 240 CLASSIC 24H	KIT RADIOS +CABECILLAS MP30LTD FRONT 24H V1	Sapim CX-Ray TCS Aero. 14G(2mm). J-Bend. 293mm. Black	2	XB61
				Sapim CX-Ray TCS Aero. 14G (2mm). J-Bend. 291mm. Black	2	
				Sapim Alloy Double Square 2x18mm. Black	4	
	DELANTERA 29" 28H	DT SWISS 240 CLASSIC 28H	KIT RADIOS +CABECILLAS MP30LTD FRONT 28H V1	Sapim CX-Ray TCS Aero. 14G (2mm). J-Bend. 299mm. Black	2	XB65
				Sapim CX-Ray TCS Aero. 14G (2mm). J-Bend. 297mm. Black	2	
				Sapim Alloy Double Square 2x18mm. Black	4	
	TRASERA 29" 28H	DT SWISS 240 CLASSIC 28H	KIT RADIOS +CABECILLAS MP30LTD REAR 28H V1	Sapim CX-Ray TCS Aero. 14G (2mm). J-Bend. 295mm. Black	2	XB86
				Sapim CX-Ray TCS Aero. 14G (2mm). J-Bend. 296mm. Black	2	
				Sapim Alloy Double Square 2x18mm. Black	4	
MP30 LTD V2 desde MY2025	DELANTERA 29" 24H	OQUO LTD SP DT SWISS INSIDE 240 24H	KIT RADIOS +CABECILLAS MP30LTD FRONT 24H V2	DT aerolite T-shape Straightpull 2.0-(0.9x2.2)-2mm. 301mm. Black	4	XH58
				DT Alloy Double Square 2x15mm.	4	
	TRASERA 29" 28H	OQUO LTD SP DT SWISS INSIDE 240 28H	KIT RADIOS +CABECILLAS MP30LTD REAR 28H V2	DT aerolite T-shape Straightpull 2.0-(0.9x2.2)-2mm. 304mm. Black	4	XH59
				DT Alloy Double Square 2x15mm.	4	
MP30 TEAM V1 hasta MY2024	DELANTERA 29" 28H	DT SWISS 350 CLASSIC 28H	KIT RADIOS +CABECILLAS MP30TEAM FRONT 28H V1	Sapim D-Sprint. Butted. 14G (2mm).J-Bend. 298m. Black	2	XC03
				Sapim D-Sprint. Butted. 14G (2mm).J-Bend. 297m. Black	2	
				Sapim Brass Polyax 2x14mm. Black	4	
	TRASERA 29" 28H	DT SWISS 350 CLASSIC 28H	KIT RADIOS +CABECILLAS MP30TEAM REAR 28H V1	Sapim D-Sprint. Butted. 14G (2mm).J-Bend. 294m. Black	2	XC12
				Sapim D-Sprint. Butted. 14G (2mm).J-Bend. 295m. Black	2	
				Sapim Brass Polyax 2x14mm. Black	4	
MP30 TEAM V2 desde MY2025	DELANTERA 29" 28H	OQUO TEAM SP DT SWISS INSIDE 350 28H	SPOKE + SPOKE NIPPLES KIT MP30TEAM FRONT 28H V2	Sapim Sprint SP Butted 2.0/1.7/2.0 305mm. Black	4	XH61
				Sapim Alloy Double Square 2x18mm. Black	4	
	TRASERA 29" 28H	OQUO TEAM SP DT SWISS INSIDE 350 28H	SPOKE + SPOKE NIPPLES KIT MP30TEAM REAR 28H V2	Sapim Sprint SP Butted 2.0/1.7/2.0 304mm. Black	4	XH62
				Sapim Alloy Double Square 2x18mm. Black	4	
MP28 PRO hasta MY2023	DELANTERA 29" 28H	DT SWISS 350 CLASSIC 28H	KIT RADIOS +CABECILLAS MP28PRO FRONT 28H V1	Sapim Race. Butted. 14G (2mm).J-Bend. 298mm. Black	2	XC33
				Sapim Race. Butted. 14G (2mm). J-Bend. 297mm. Black	2	
				Sapim Brass Polyax 2x14mm. Black	4	
	TRASERA 29" 28H	DT SWISS 350 CLASSIC 28H	KIT RADIOS +CABECILLAS MP28PRO REAR 28H V1	Sapim Race. Butted. 14G (2mm).J-Bend. 296mm. Black	2	XC14
				Sapim Race. Butted. 14G (2mm). J-Bend. 297mm. Black	2	
				Sapim Brass Polyax 2x14mm. Black	4	
MP28 PRO desde MY2024	DELANTERA 29" 28H	DT SWISS 370 CLASSIC 28H	KIT RADIOS +CABECILLAS MP28PRO FRONT 28H V2	Sapim Race. Butted. 14G (2mm). J-Bend. 297mm. Black	2	XD46
				Sapim Race. Butted. 14G (2mm). J-Bend. 296mm. Black	2	
				Sapim Brass Polyax 2x14mm. Black	4	
	TRASERA 29" 28H	DT SWISS 370 CLASSIC 28H	KIT RADIOS +CABECILLAS MP28PRO REAR 28H V2	Sapim Race. Butted. 14G (2mm). J-Bend. 296mm. Black	2	XD47
				Sapim Race. Butted. 14G (2mm). J-Bend. 296mm. Black	2	
				Sapim Brass Polyax 2x14mm. Black	4	

Pincha en el número de artículo para comprar online.

## RADIO. KITS DE RADIO RUEDAS OQUO

## MOUNTAIN CONTROL (MC)

MODELO RUEDA	DELANTERA / TRASERA	BUJE	DESCRIPCIÓN RECAMBIO	INCLUYE	CANT.	COD. ART. ORBEA
MC32 LTD V1 hasta MY2025	DELANTERA 29" 28H	DT SWISS 350 CLASSIC 28H	KIT RADIOS +CABECILLAS MC32LTD FRONT 28H V1	Sapim D-Sprint. Butted. 14G (2mm).J-Bend. 298m. Black	2	XC29
				Sapim D-Sprint. Butted. 14G (2mm). J-Bend. 301m. Black	2	
				Sapim Brass Polyax 2x14mm. Black	4	
	TRASERA 29" 32H	DT SWISS 350 CLASSIC 32H	KIT RADIOS +CABECILLAS MC32LTD REAR 32H V1	Sapim Race. Butted 14G (2mm).J-Bend. 292mm. Black	4	XC30
Sapim Brass Polyax 2x14mm. Black				4		
MC32 LTD V2 desde MY2026	DELANTERA 29" 28H	OQUO LTD JBEND 28H DT INSIDE 350	KIT RADIOS +CABECILLAS MC32LTD FRONT 28H V2	Sapim Sprint. Butted. 14G (2mm).J-Bend. 299m. Black	4	XJ99
				Sapim Brass Polyax 2x14mm. Black	4	
	TRASERA 29" 32H	OQUO LTD JBEND 32H DT INSIDE 350 DEG	KIT RADIOS +CABECILLAS MC32LTD REAR 32H V2	Sapim Race. Butted 14G (2mm).J-Bend. 291mm. Black	4	XK00
				Sapim Brass Polyax 2x14mm. Black	4	
MC32 TEAM V1 hasta MY2024	DELANTERA 29" 28H	DT SWISS 350 CLASSIC 28H	KIT RADIOS +CABECILLAS MC32TEAM FRONT 28H V1	Sapim D-Sprint. Butted. 14G (2mm).J-Bend. 299m. Black	2	XC42
				Sapim D-Sprint. Butted. 14G (2mm). J-Bend. 297m. Black	2	
				Sapim Brass Polyax 2x14mm. Black	4	
	TRASERA 29" 32H	DT SWISS 350 CLASSIC 32H	KIT RADIOS +CABECILLAS MC32TEAM REAR 29 32H V1	Sapim Race. Butted 14G (2mm).J-Bend. 291mm. Black	4	XC43
				Sapim Brass Polyax 2x14mm. Black	4	
	TRASERA 27.5" 32H	DT SWISS 350 CLASSIC 32H	KIT RADIOS +CABECILLAS MC32TEAM REAR 27.5 32H V1	Sapim Race. Butted 14G (2mm).J-Bend. 271mm. Black	4	XC44
Sapim Brass Polyax 2x14mm. Black				4		
MC32 TEAM V2 MY2025	DELANTERA 29" 28H	DT SWISS 350 CLASSIC 28H	KIT RADIOS +CABECILLAS MC32TEAM FRONT 28H V2	Sapim D-Light Butted. 14G (2 mm). J-Bend. 302 mm. Black	2	XH63
				Sapim D-Light Butted. 14G (2 mm). J-Bend. 300 mm. Black	2	
				Sapim Alloy Double Square 2x18mm. Black	4	
	TRASERA 29" 32H	DT SWISS 350 CLASSIC 32H	KIT RADIOS +CABECILLAS MC32TEAM REAR 29 32H V2	Sapim Sprint. Butted 14G (2mm).J-Bend. 295 mm. Black	4	XH64
				Sapim Alloy Double Square 2x18mm. Black	4	
	TRASERA 27.5" 32H	DT SWISS 350 CLASSIC 32H	KIT RADIOS +CABECILLAS MC32TEAM REAR 27.5 32H V2	Sapim Sprint. Butted 14G (2mm).J-Bend. 276 mm. Black	4	XH65
Sapim Alloy Double Square 2x18mm. Black				4		
MC32 TEAM V3 desde MY2026	DELANTERA 29" 28H	OQUO LTD JBEND 28H DT INSIDE 350	KIT RADIOS +CABECILLAS MC32TEAM FRONT 28H V3	Sapim D-Light. Butted 14G (2mm).J-Bend. 298mm. Black	2	XK02
				Sapim D-Light. Butted 14G (2mm).J-Bend. 297mm. Black	2	
				Sapim Alloy Double Square 2x18mm. Black	4	
	TRASERA 29" 32H	OQUO LTD JBEND 32H DT INSIDE 350 DEG	KIT RADIOS +CABECILLAS MC32TEAM REAR 29 32H V3	Sapim Sprint. Butted. 14G (2mm). J-Bend. 291m. Black	4	XK03
				Sapim Alloy Double Square 2x18mm. Black	4	
	TRASERA 27.5" 32H	OQUO LTD JBEND 32H DT INSIDE 350 DEG	KIT RADIOS +CABECILLAS MC32TEAM REAR 27.5 32H V3	Sapim Sprint. Butted. 14G (2mm). J-Bend. 272m. Black	4	XK04
Sapim Alloy Double Square 2x18mm. Black				4		
MC32 TEAM RALLON DH (OEM) desde MY2026	DELANTERA 29" 28H	DT SWISS 350 CLASSIC 28H	KIT RADIOS +CABECILLAS MC32TEAM RALLON DH FRONT 28H (OEM) V1	Sapim Race. Butted 14G (2mm).J-Bend. 296mm. Black	4	XK05
				Sapim Brass Polyax 2x14mm. Black	4	
	TRASERA 27.5" 32H	DT SWISS 350 CLASSIC 32H	KIT RADIOS +CABECILLAS MC32TEAM RALLON DH REAR 27.5 32H (OEM) V1	Sapim Race. Butted 14G (2mm).J-Bend. 272mm. Black	4	XK06
				Sapim Brass Polyax 2x14mm. Black	4	

## RADIO. KITS DE RADIO RUEDAS OQUO

## MOUNTAIN CONTROL (MC) POWER

MODELO RUEDA	DELANTERA / TRASERA	BUJE	DESCRIPCIÓN RECAMBIO	INCLUYE	CANT.	COD. ART. ORBEA
MC32 LTD POWER hasta MY2023	TRASERA 29" 32H	DT SWISS 350 HYBRID CLASSIC 32H hasta MY2023	KIT RADIOS +CABECILLAS MC32LTD POWER REAR 32H V1	Sapim E-Light. Butted 14G (2mm).J-Bend. 292mm. Black	2	XC31
				Sapim E-Light. Butted 14G (2mm). J-Bend. 294mm. Black	2	
				Sapim Brass Polyax 2x14mm. Black	4	
MC32 LTD POWER desde MY2024	DELANTERA 29" 28H	DT SWISS 350 HYBRID CLASSIC 28H desde MY2024	KIT RADIOS +CABECILLAS MC32LTD POWER FRONT 28H V2	Sapim E-Light. Butted 14G (2mm).J-Bend. 298 mm. Black	2	XD49
				Sapim E-Light. Butted 14G (2 mm). J-Bend. 299 mm. Black	2	
				Sapim Brass Polyax 2 x 14 mm. Black	4	
	TRASERA 29" 32H	DT SWISS 350 HYBRID CLASSIC 32H desde MY2024	KIT RADIOS +CABECILLAS MC32LTD POWER REAR 32H V2	Sapim E-Light. Butted 14G (2mm).J-Bend. 292 mm. Black	2	XD50
				Sapim E-Light. Butted 14G (2 mm). J-Bend. 291 mm. Black	2	
				Sapim Brass Polyax 2 x 14 mm. Black	4	
MC32 TEAM POWER V1 hasta MY2023	DELANTERA 29" 32H	DT SWISS 350 HYBRID CLASSIC 32H hasta MY2023	KIT RADIOS +CABECILLAS MC32TEAM POWER FRONT 32H V1	Sapim E-Light. Butted. 14G (2mm).J-Bend. 292m. Black	2	XC45
				Sapim E-Light. Butted. 14G (2mm). J-Bend. 294m. Black	2	
				Sapim Brass Polyax 2x14mm. Black	4	
	TRASERA 29" 32H	DT SWISS 350 HYBRID CLASSIC 32H hasta MY2023	KIT RADIOS +CABECILLAS MC32TEAM POWER REAR 32H V1	Sapim E-Light. Butted. 14G (2mm).J-Bend. 291mm. Black	2	XC49
				Sapim E-Light. Butted. 14G (2mm). J-Bend. 293mm. Black	2	
				Sapim Brass Polyax 2x14mm. Black	4	
MC32 TEAM POWER V2 MY2024	DELANTERA 29" 28H	DT SWISS 350 HYBRID CLASSIC 28H desde MY2024	KIT RADIOS +CABECILLAS MC32TEAM POWER FRONT 28H V2	Sapim E-Light. Butted. 14G (2mm).J-Bend. 297m. Black	2	XD51
				Sapim E-Light. Butted. 14G (2mm).J-Bend. 298m. Black	2	
				Sapim Brass Polyax 2x14mm. Black	4	
	TRASERA 29" 32H	DT SWISS 350 HYBRID CLASSIC 32H desde MY2024	KIT RADIOS +CABECILLAS MC32TEAM POWER REAR 29 32H V2	Sapim E-Light. Butted. 14G (2mm).J-Bend. 291mm. Black	2	XD52
				Sapim E-Light. Butted. 14G (2mm).J-Bend. 292mm. Black	2	
				Sapim Brass Polyax 2x14mm. Black	4	
	TRASERA 27.5" 32H	DT SWISS 350 HYBRID CLASSIC 32H desde MY2024	KIT RADIOS +CABECILLAS MC32TEAM POWER REAR 27.5 32H V2	Sapim E-Light. Butted. 14G (2mm).J-Bend. 271mm. Black	4	XD54
				Sapim Brass Polyax 2x14mm. Black	4	
	MC32 TEAM POWER V3 MY2025	DELANTERA 29" 28H	DT SWISS 350 HYBRID CLASSIC 28H desde MY2024	KIT RADIOS +CABECILLAS MC32TEAM POWER FRONT 28H V3-V4	Sapim E-Light. Butted. 14G (2mm).J-Bend. 301mm. Black	2
Sapim E-Light. Butted. 14G (2mm).J-Bend. 300mm. Black					2	
Sapim Alloy Double Square 2x18mm. Black					4	
TRASERA 29" 32H		DT SWISS 350 HYBRID CLASSIC 32H desde MY2024	KIT RADIOS +CABECILLAS MC32TEAM POWER REAR 29 32H V3-V4	Sapim E-Light. Butted. 14G (2mm).J-Bend. 294 mm. Black	2	XH72
				Sapim E-Light. Butted. 14G (2mm).J-Bend. 295mm. Black	2	
				Sapim Alloy Double Square 2x18mm. Black	4	
TRASERA 27.5" 32H		DT SWISS 350 HYBRID CLASSIC 32H desde MY2024	KIT RADIOS +CABECILLAS MC32TEAM POWER REAR 27.5 32H V3-V4	Sapim E-Light. Butted. 14G (2mm).J-Bend. 276 mm. Black	2	XH73
				Sapim E-Light. Butted. 14G (2mm).J-Bend. 275 mm. Black	2	
				Sapim Alloy Double Square 2x18mm. Black	4	

Pincha en el número de artículo para comprar online.

## RADIO. KITS DE RADIOS RUEDAS OQUO

## MOUNTAIN CONTROL (MC) POWER

MODELO RUEDA	DELANTERA / TRASERA	BUJE	DESCRIPCIÓN RECAMBIO	INCLUYE	CANT.	COD. ART. ORBEA
MC32 TEAM POWER V4 desde MY2026	DELANTERA 29" 28H	DT SWISS 350 HYBRID CLASSIC 28H desde MY2024	KIT RADIOS +CABECILLAS MC32TEAM POWER FRONT 28H V3-V4	Sapim E-Light. Butted. 14G (2mm).J-Bend. 301mm. Black	2	XH71
				Sapim E-Light. Butted. 14G (2mm).J-Bend. 300mm. Black	2	
				Sapim Alloy Double Square 2x18mm. Black	4	
	TRASERA 29" 32H	DT SWISS 350 HYBRID CLASSIC 32H desde MY2024	KIT RADIOS +CABECILLAS MC32TEAM POWER REAR 29 32H V3-V4	Sapim E-Light. Butted. 14G (2mm).J-Bend. 294 mm. Black	2	XH72
				Sapim E-Light. Butted. 14G (2mm).J-Bend. 295mm. Black	2	
				Sapim Alloy Double Square 2x18mm. Black	4	
	TRASERA 27.5" 32H	DT SWISS 350 HYBRID CLASSIC 32H desde MY2024	KIT RADIOS +CABECILLAS MC32TEAM POWER REAR 27.5 32H V3-V4	Sapim E-Light. Butted. 14G (2mm).J-Bend. 276 mm. Black	2	XH73
				Sapim E-Light. Butted. 14G (2mm).J-Bend. 275 mm. Black	2	
				Sapim Alloy Double Square 2x18mm. Black	4	

Pincha en el número de artículo para comprar online.

## VÁLVULAS TUBELESS OQUO

### Instalación de válvula Tubeless en llantas asimétricas

En algunas llantas OQUO con perfil asimétrico es necesario el uso del adaptador asimétrico entre la llanta y la tuerca de la válvula para que el conjunto de la válvula asiente correctamente en el exterior de la llanta.

El adaptador se incluye con las ruedas OQUO con perfil asimétrico que lo necesiten.

Consulta la tabla de longitud de válvula en la siguiente sección para saber qué modelos de ruedas OQUO necesitan la instalación del adaptador asimétrico de válvula.

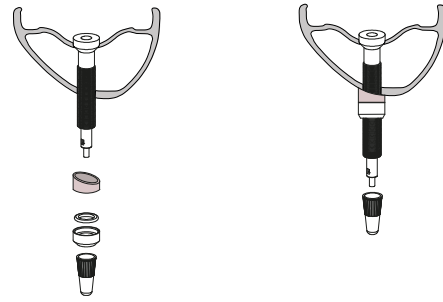

### Longitud de válvula tubeless

Consulta la tabla a continuación para conocer la longitud de válvula Tubeless que utilizan tus ruedas OQUO

FAMILIA	MODELO RUEDA	LONGITUD DE VÁLVULA		ADAPTADOR VÁLVULA ASIMÉTRICO
		Delantera	Trasera	
MOUNTAIN PERFORMANCE	MP30LTD	44 mm	44 mm	NO
	MP30TEAM	44 mm	44 mm	NO
	MP28PRO	40 mm	40 mm	SI XB66
MOUNTAIN CONTROL	MC32LTD	44 mm	44 mm	NO
	MC32LTD POWER	44 mm	44 mm 57 mm on Wild with valve magnet	NO
	MC32TEAM V1 (hasta MY2024)	44 mm	44 mm	SI XB66
	MC32TEAM V2-V3 (desde MY2025)	44 mm	44 mm	SI XH67
	MC32TEAM RALLON DH (desde MY2026)	44 mm	44 mm	SI XH67
	MC32TEAM POWER V1 (hasta MY2023)	44 mm	44 mm 57 mm on Wild with valve magnet	SI XB66
	MC32TEAM POWER V2-V4 (desde MY2045)	44 mm	44 mm 57 mm on Wild with valve magnet	SI XH67

Pincha en el número de artículo para comprar online.

### Herramienta integrada en el tapón de la válvula OQUO

Las válvulas Tubeless OQUO integran una herramienta para desmontar el obús de la válvula Tubeless en el tapón de la válvula.

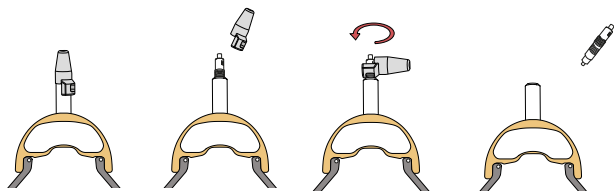

### Accesorios OQUO

Nº ART.	DESCRIPCIÓN	CANT.	
X803	<b>KIT VÁLVULAS TUBELESS OQUO 44mm</b> Con tapón herramienta obús	2	
X804	<b>KIT VÁLVULAS TUBELESS OQUO 44mm + 57mm</b> Con tapón herramienta obús No incluye adaptadores llantas asimétricas		
XB67	<b>KIT TAPONES VÁLVULA TUBELESS OQUO</b> Herramienta obús integrada	2	
XB66	<b>KIT ADAPTADORES VÁLVULA LLANTA ASIMÉTRICA V1</b> Consulta la tabla de la sección anterior para saber si tus ruedas Oquó necesitan adaptador	2	
XH67	<b>KIT ADAPTADORES VÁLVULA LLANTA ASIMÉTRICA V2</b> Consulta la tabla de la sección anterior para saber si tus ruedas Oquó necesitan adaptador	2	
XH28	<b>KIT OBUSES VÁLVULA OQUO</b>	10	

Pincha en el número de artículo para comprar online.

---

## CONSTRUCCIÓN DE RUEDAS OQUO



---

Esta sección da instrucciones generales de radiado y finalización de las ruedas OQUO para dealers OQUO que deban sustituir una llanta OQUO previa aprobación de la marca, y no pretende ser un manual de construcción de ruedas de bicicleta.

La construcción de ruedas de manera correcta y segura requiere amplios conocimientos técnicos y experiencia. Usuarios o técnicos que no hayan recibido la formación permitente o tengan la experiencia necesaria no deben construir una rueda de bicicleta para su posterior uso.



---

La construcción de una rueda de forma incorrecta puede comprometer la integridad estructural y durabilidad de la misma, pudiendo ser la causa de rotura de los componentes no cubierta por las condiciones de garantía, y que puede derivar en lesiones graves, incluso la muerte.

### HERRAMIENTAS

Consulta la sección Mantenimiento de ruedas OQUO, que describe las herramientas necesarias para el correcto mantenimiento y construcción de ruedas OQUO.

Utiliza siempre las herramientas y productos adecuados para la construcción de ruedas. Herramientas inadecuadas o en mal estado, o el uso de productos no específicos, pueden causar daños en los componentes que no están cubiertos por las condiciones de garantía.

## LLANTAS ASIMÉTRICAS

Si la llanta tiene un perfil asimétrico (consulta la tabla de especificaciones de este manual para saber si una modelo utiliza llanta asimétrica), siempre orienta la llanta siguiendo las instrucciones a continuación.

- **Llantas delanteras**

El offset de la llanta debe quedar orientado hacia el lado de la transmisión (drive side)

- **Llantas traseras**

El offset de la llanta debe quedar orientado hacia el lado opuesto de la transmisión (non-drive side).

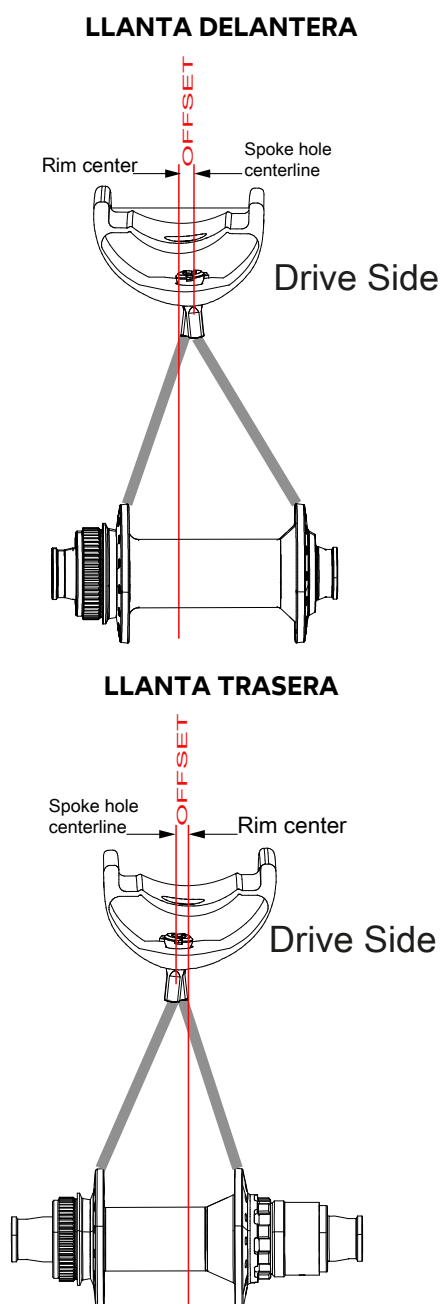

## LLANTAS SIMÉTRICAS

En el caso de llantas simétricas (sin offset), orienta la llanta de manera que cualquier calca o pegatina sea legible desde el mismo lado de la bici que lo era en la rueda original.

## AGUJEROS DE RADIOS DIRECCIONALES

Si la llanta tiene agujeros para radios direccionales, siempre construye la rueda de manera que la orientación de los agujeros en la llanta coincidan con el lado del buje correspondiente.

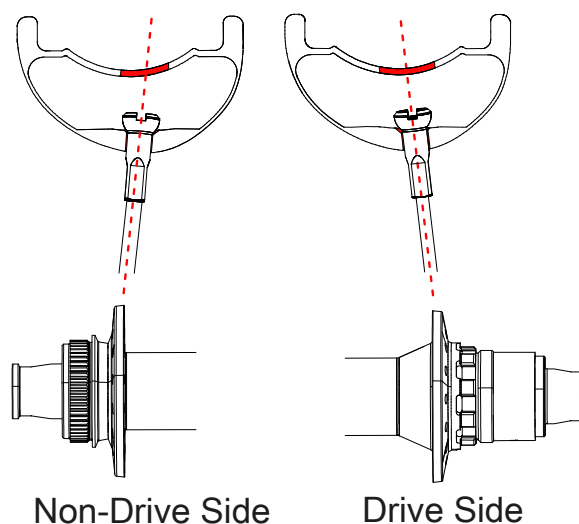

## LLANTAS ESPECÍFICAS PARA RUEDA DELANTERA Y TRASERA

En modelos OQUO con llanta específica para rueda delantera o trasera, asegúrate de usar la llanta específica para la rueda para la que fué diseñada.

En la tabla de especificaciones técnicas de este manual puedes comprobar si tu modelo utiliza llantas específicas para rueda delantera o trasera.

Las llantas específicas para rueda delantera incluyen la letra F en el nombre del modelo de la llanta.

Las llantas específicas para rueda trasera incluyen la letra R en el nombre del modelo de la llanta.

Las llantas no específicas para rueda trasera o trasera incluyen la letra B en el nombre del modelo de la llanta.

## RADIOS Y CABECILLAS

Siempre utiliza el modelo de radios y cabecillas especificados por OQUO para un modelo de rueda.

Puedes comprobar los componentes de cada modelo en la tabla de especificaciones técnicas de este manual.

### RADIOS STRAIGHTPULL CLÁSICOS O T-SHAPE

Dependiendo del alojamiento para la cabeza de los radios en un buje straightpull, es necesario montar radios straightpull clásicos o T-Shape.

En los bujes para radios straightpull T-Shape, el alojamiento para la cabeza de los radios es rectangular, permitiendo encajar la cabeza del radio e impidiendo que se tuerzan o aflojen.

En los bujes para radios straightpull clásicos, el alojamiento para la cabeza de los radios es redondeada, por lo que los radios deberán tener cabeza estándar.

### RADIOS STRAIGHTPULL T-SHAPE



### CABECILLAS CON ARANDELAS DE REFUERZO

Algunas cabecillas utilizan arandelas de refuerzo que se instalan entre la cabecilla y la pared de la llanta.

Comprueba en la tabla de especificaciones de tus ruedas, si es necesario instalar arandelas de refuerzo.

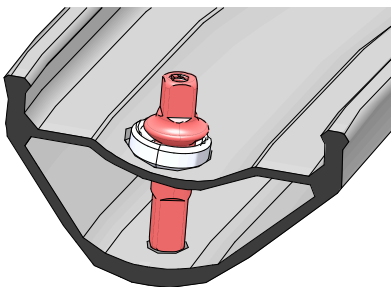

## PATRONES DE RADIADO RADIOS J-BEND

### AVISO

En montajes con radios straight pull, al contrario que en montajes con radios J-bend, el patrón de radiado viene predefinido por el buje, no siendo posible elegirlo en el montaje de la rueda.

Siempre monta la rueda siguiendo el patrón de radiado original para cada lado de la rueda.

Asegúrate de que los radios se cruzan correctamente (arriba o abajo) entre ellos.

### 3 CRUCES

Cada radio se cruza con otros tres radios del mismo lado de la rueda antes de amarrarse a la llanta.

Dependiendo del lado de la aleta del buje del que salga el radio, su posición respecto a los otros tres radios que cruza puede ser de dos maneras.

Si el radio sale por el lado exterior de la aleta del buje, la posición respecto a los radios con los que cruza será:

- 01 Por encima
- 02 Por encima
- 03 Por debajo

Si el radio sale por el lado interior de la aleta del buje, la posición respecto a los radios con los que cruza será:

- 01 Por debajo
- 02 Por debajo
- 03 Por encima

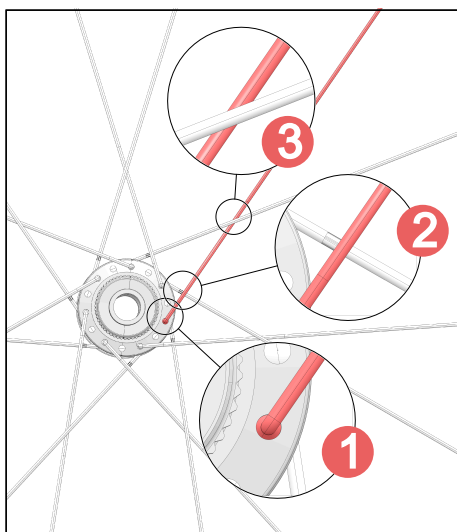

### 2 CRUCES

Cada radio se cruza con otros dos radios del mismo lado de la rueda antes de amarrarse a la llanta.

Dependiendo del lado de la aleta del buje del que salga en radio, su posición respecto a los otros dos radios que cruza puede ser de dos maneras.

Si el radio sale por el lado exterior de la aleta del buje, la posición respecto a los radios con los que cruza será:

- 01 Por encima
- 02 Por debajo

Si el radio sale por el lado interior de la aleta del buje, la posición respecto a los radios con los que cruza será:

- 01 Por debajo
- 02 Por encima

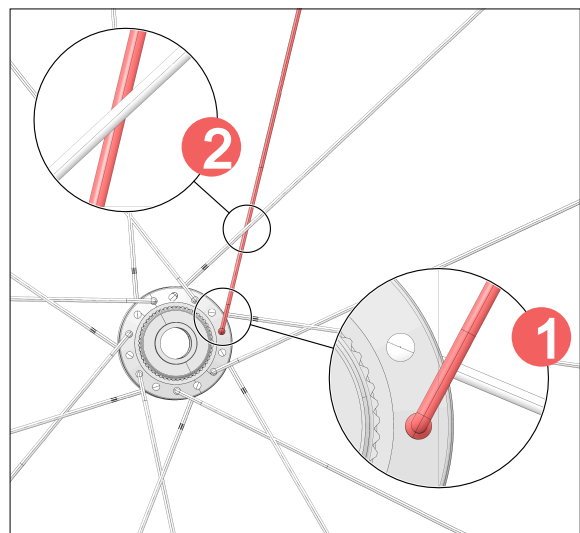

**POSICIÓN DE RADIOS J-BEND "LEADING" Y "TRAILING"**



En montajes con buje y radios straight pull, la posición de los radios en el buje es unidireccional, no siendo posible elegirla en el montaje de la rueda

Comprueba la posición de los radios "leading" y "trailing" en la tabla de especificaciones de este manual o en la rueda original y radia la rueda de igual manera para cada lado de una rueda.

**Radio "Trailing"**

Radios que salen del buje en la dirección opuesta al sentido de rotación de la rueda.

**Radio "Leading"**

Radios que salen del buje en la misma dirección que el sentido de rotación de la rueda.

Las siguientes imágenes son ejemplos de radiado. Comprueba el radiado de la rueda original o el patrón de radiado en la tabla de especificaciones.



Sentido de rotación de la rueda

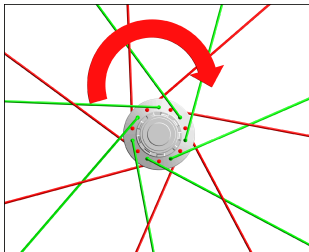

RUEDA TRASERA DRIVE SIDE

**Trailing:** Por fuera de la aleta del buje  
**Leading:** Por dentro de la aleta del buje

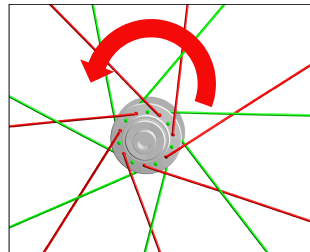

RUEDA TRASERA NON- DRIVE SIDE

**Trailing:** Por dentro de la aleta del buje  
**Leading:** Por fuera de la aleta del buje

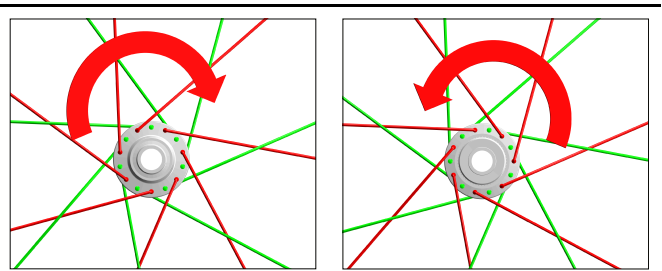

RUEDA DELANTERA DRIVE SIDE

**Trailing:** Por dentro de la aleta del buje  
**Leading:** Por fuera de la aleta del buje

RUEDA DELANTERA NON- DRIVE SIDE

**Trailing:** Por dentro de la aleta del buje  
**Leading:** Por fuera de la aleta del buje

**POSICIÓN DEL AGUJERO DE LA VÁLVULA**

El agujero para la válvula de la llanta deber quedar posicionado entre dos radios paralelos para facilitar el inflado de la cubierta.



### POSICIÓN DEL LOGO DEL BUJE

Por motivos estéticos, si el buje dispone de un logo en el cuerpo del mismo, la posición del buje respecto a la llanta debería permitir que el logo del buje estuviese alineado con el agujero para la válvula de la llanta.

Este punto no tiene ningún efecto en la función de la rueda, por lo que montajes que no cumplan esta condición se consideran válidos a todos los efectos mientras el resto de parámetros de montaje sean correctos.

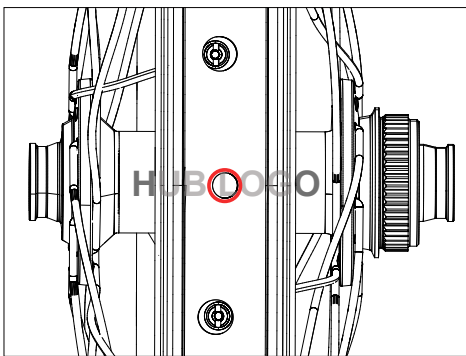

### PROCESO DE TENSIONADO Y CENTRADO.

La construcción de ruedas de manera correcta y segura requiere amplios conocimientos técnicos y experiencia. Usuarios o técnicos que no hayan recibido la formación permitida o tengan la experiencia necesaria no deben construir una rueda de bicicleta para su posterior uso.



Esta manual no incluye instrucciones completas sobre el proceso de radiado y tensionado completo de ruedas de bicicleta, sino guías generales sobre el acabado de ruedas OQUO y las tolerancias permitidas. Sólo es una guía de instrucciones generales de radiado y finalización de las ruedas OQUO para dealers OQUO que deban sustituir una llanta OQUO previa aprobación de la marca, y no pretende ser un manual de construcción de ruedas de bicicleta.



La construcción de una rueda de forma incorrecta puede comprometer la integridad estructural y durabilidad de la misma, pudiendo ser la causa de rotura de los componentes no cubierta por las condiciones de garantía, y que puede derivar en lesiones graves, incluso la muerte.

Una vez la rueda haya sido radiada y las cabecillas instaladas sin añadir tensión a la rueda, procede al centrado de la rueda hasta hasta las especificaciones de tolerancias descritas en este manual. Añade tensión a la rueda poco a poco y uniformemente. Realiza las comprobaciones a continuación tras ajustar unos pocos radios.

OQUO recomienda que el proceso de comprobación de alineación de la rueda sea:

- 01** Comprobación de alineación lateral
- 02** Comprobación de centricidad radial
- 03** Comprobación de aparaguado en ambos lados de la rueda.

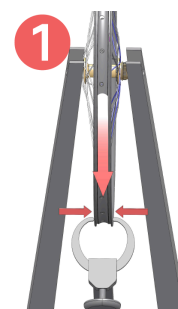

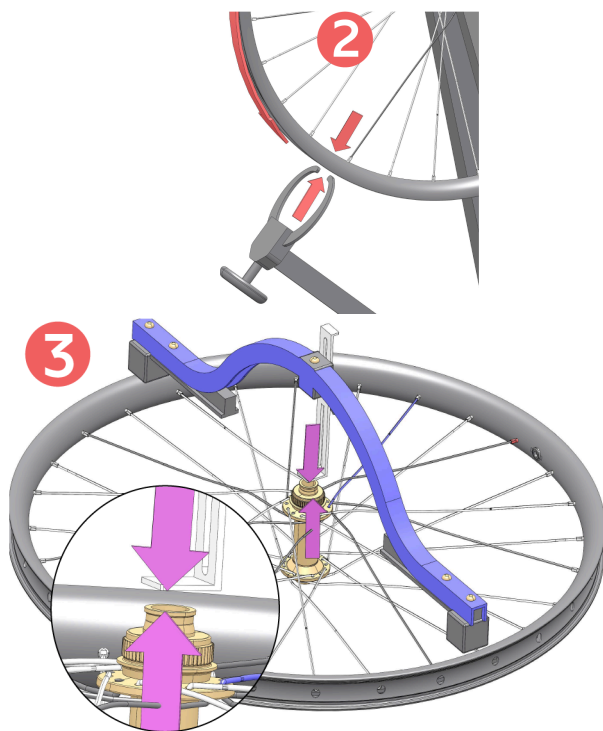

Repite estas comprobaciones tantas veces como sea necesario durante el proceso de tensionado de radios siempre que añadas tensión a varios radios para evitar desviaciones excesivas que puede dañar la llanta.

#### AVISO

Tras cada comprobación de alineación lateral, radial y aparaguado, destensa la rueda para que los radios se vayan acomodando en posición y las comprobaciones sean reales.

Puedes destensar la rueda apoyando un extremo del buje en una superficie sólida y empujando lados opuestos de la llanta en la dirección en que está apoyado el buje con las manos poniendo tu propio peso sobre tus manos.

Realiza esta comprobación en ambos lados de la rueda.

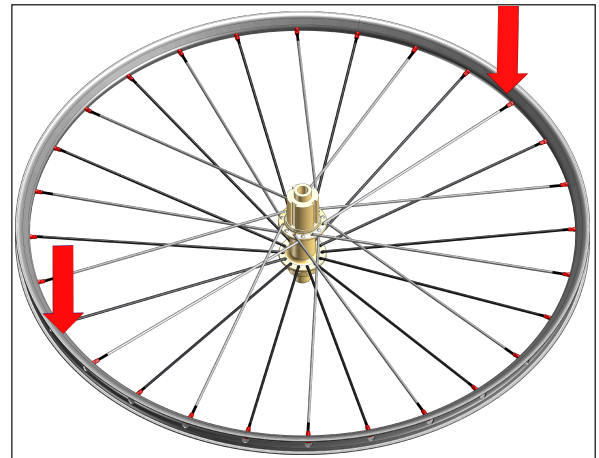

#### COMPROBACIÓN DE LA TENSIÓN DE LOS RADIOS

Consulta la tensión objetivo del lado más tenso de cada rueda para tu modelo en la Tabla de Especificaciones Técnicas de este manual (apartado Radios). Una vez alcanzada la tensión objetivo en el lado especificado para la rueda, y estando los valores de desviación lateral, radial y de aparaguado dentro de las tolerancias marcadas, la tensión de los radios del lado menos tenso debe ser homogénea.

Siempre usa un tensiómetro de calidad y comprueba regularmente su calibración según las instrucciones del fabricante.

Sigue las instrucciones del fabricante para su correcto uso y para interpretar de manera adecuada la lectura de tensión dependiendo de las especificaciones de los radios.

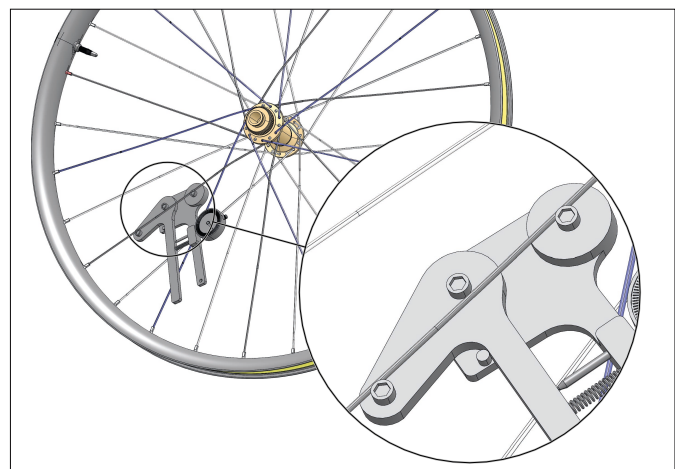

## COMPUESTO DE MONTAJE

Si estás realizando el mantenimiento o radiado de una de nuestras ruedas, una vez la rueda está correctamente centrada y tensionada, recomendamos el uso de un compuesto fijador de roscas de radios de resistencia media lo más fluido posible en las roscas de los radios.

## OBJETIVOS Y TOLERANCIAS DE MONTAJE DE RUEDAS OQUO

TENSIÓN DE MONTAJE OBJETIVO DE RUEDAS OQUO	
TENSIÓN	<p><b>Consulta la tensión objetivo del lado más tenso de cada rueda para tu modelo en la Tabla de Especificaciones Técnicas de este manual (apartado Radios)</b></p> <p>Una vez alcanzada la tensión objetivo en el lado especificado para la rueda, y estando los valores de desviación lateral, radial y de aparaguado dentro de las tolerancias marcadas, la tensión de los radios del lado menos tenso debe ser homogénea.</p>
	<b>TOLERANCIA DE TENSIÓN MEDIA DE LOS RADIOS DEL LADO MÁS TENSO DE LA RUEDA</b>
	+/- 5%

Siempre usa un tensiómetro de calidad y comprueba regularmente su calibración según las instrucciones del fabricante. Sigue las instrucciones del fabricante para su correcto uso y para interpretar de manera adecuada la lectura de tensión dependiendo de las especificaciones de los radios.

DESVIACIÓN		LATERAL	RADIAL	APARAGUADO
	Aluminio	0.4mm	0.6mm	0.6mm
Carbono	0.3mm	0.6mm	0.3mm	

---

## INFORMACIÓN ADICIONAL

Encuentra más información de OQUO en redes

### FACEBOOK

[www.facebook.com/oquo.wheels](http://www.facebook.com/oquo.wheels)

### INSTAGRAM

[www.instagram.com/oquo.wheels/](http://www.instagram.com/oquo.wheels/)

### LINKEDIN

[www.linkedin.com/company/oquowheels/](http://www.linkedin.com/company/oquowheels/)

### YOUTUBE

[www.youtube.com/channel/UCpXzSOB\\_9oLzLzAnnwuaGCg](http://www.youtube.com/channel/UCpXzSOB_9oLzLzAnnwuaGCg)

### MANUALES

Descarga la última versión de este manual, así como del resto de productos OQUO en:

[www.oquowheels.com/en-int/support/manuals](http://www.oquowheels.com/en-int/support/manuals)

### CONTACTO

Si tienes cualquier consulta sobre nuestros productos, visita:

[www.oquowheels.com/en-int/support/contact](http://www.oquowheels.com/en-int/support/contact)

---

**Orbea OQUO SL 2025**  
**Polígono Industrial Kareaga, 2. NAV 49,**  
**Markina-Xemein. 48270. Bizkaia**  
**T. 0034 943 171 950**

Todos los derechos reservados. Queda prohibida la modificación de este documento.

El presente manual técnico sobre producto tiene exclusivamente una finalidad informativa respecto al montaje, instalación y mantenimiento de dicho producto, y como tal puede estar sujeto a cambios de especificaciones y/o actualizaciones futuras de dicha información por parte del fabricante. Su contenido carece de valor publicitario o contractual alguno en relación al producto que se describe, y su contenido no debe ser tomado en cuenta por el usuario como un elemento de asesoramiento respecto a su decisión sobre la compra del producto. Por ello, no asumimos ninguna responsabilidad frente al usuario o tercero, si este Manual se utiliza para un fin distinto al previsto y especificado en el mismo.

Todos los derechos reservados. Queda prohibida la modificación de este documento. El contenido de este manual queda sujeto a cambios de especificaciones sin previo aviso.

Consulta la versión más reciente en: [www.oquowheels.com](http://www.oquowheels.com)

---

## INDEX

<b>Einleitung</b>	<b>134</b>
<b>Die verschiedenen Handbücher</b>	<b>135</b>
<b>Erläuterung der Symbole</b>	<b>136</b>
<b>Allgemeine Warnhinweise im technischen Handbuch</b>	<b>137</b>
<b>Technische Daten und Montageinformationen für OQUO-Laufräder</b>	<b>138</b>
ÜBERSICHT ÜBER DAS OQUO-MTB-LAUFRADPROGRAMM	138
Mountain Performance (MP)	139
MP30 LTD (bis MJ 2024)	139
MP30 LTD (ab MJ 2025)	140
MP30 TEAM (bis MJ 2024)	141
MP30 TEAM (ab MJ 2025)	142
MP28 PRO (bis zu MY2023)	143
MP28 PRO (von MY2024)	144
Mountain Control (MC)	145
MC32 LTD (bis MJ 2025)	145
MC32 LTD (ab MJ 2026)	146
MC32 LTD POWER (bis zu MY2023)	147
MC32 LTD POWER (von MY2024)	148
MC32 TEAM (bis MJ 2024)	149
MC32 TEAM (MJ 2025)	150
MC32 TEAM (ab MJ 2026)	151
MC32 TEAM RALLON DH MJ 2026 (OEM)	152
MC32 TEAM POWER (bis zu MY2023)	153
MC32 TEAM POWER (MJ 2024)	154
MC32 TEAM POWER (MJ 2025)	155
MC32 TEAM POWER (ab MJ 2026)	156
<b>Wartung von OQUO-Laufrädern</b>	<b>157</b>
Wartungsintervall-Tabelle	157
Werkzeuge	157
<b>Nabenwartung</b>	<b>163</b>
<b>Ersatzteile</b>	<b>165</b>
OQUO DT Swiss Inside Nabenersatzteile	165
Oquo DT Swiss Inside Vorderradnaben	165
Oquo LTD DT Swiss 240 Inside Straight Pull 15x110 24-Loch Centerlock	165

Oquo TEAM DT Swiss 350 Inside Straight Pull 15x110 28-Loch Centerlock/6-Loch	166
Oquo LTD DT Swiss 350 Inside J-bend 15x110 28-Loch 6-Loch	167
Oquo DT Swiss Inside Hinterradnaben	168
Oquo LTD DT Swiss 240 Inside Straight Pull 12x148 28-Loch Centerlock	168
Oquo LTD DT Swiss 350 Inside Straight Pull 12x148 28/32H Centerlock/6-Loch	169
Oquo LTD DT Swiss Inside 350 DEG J-bend 12x148 32H 6-Loch	170
Ersatzteile für DT Swiss-Naben	171
DT Swiss Vorderradnaben	171
DT Swiss 240 J-bend 15x110 24/28-Loch Centerlock/6-Loch	171
DT Swiss 350 J-bend 15x110 28-Loch Centerlock/6-Loch	172
DT Swiss 350 J-bend 20x110 28-Loch 6-Loch	173
DT Swiss 370 J-bend 15x110 28-Loch 6-Loch	174
DT Swiss 350 Hybrid J-bend 15x110 32-Loch 6-Loch (bis MJ 2023)	175
DT Swiss 350 Hybrid J-bend 15x110 28-Loch 6-Loch (aus MJ 2024)	176
DT Swiss Hinterradnaben	177
DT Swiss 240 J-bend 12x148 28-Loch Centerlock	177
DT Swiss 350 J-bend 12x148 28/32-Loch Centerlock/6-Loch	178
DT Swiss 370 J-bend 12x148 28-Loch 6-Loch	179
DT Swiss 350 Hybrid J-bend 12x148 32-Loch 6-Loch (bis MJ 2023)	180
DT Swiss 350 Hybrid J-bend 12x148 32-Loch 6-Loch (ab MJ 2024)	181
Speichen. Speichensätze für Oquo-Laufräder	182
OQUO-Tubeless-Ventile	186
<b>Bau von OQUO-Laufrädern</b>	<b>188</b>
<b>Zusätzliche Informationen</b>	<b>196</b>

---

## EINLEITUNG

Die in diesem Handbuch enthaltenen Informationen richten sich in erster Linie an das OQUO-Vertriebsnetz und Benutzer:innen, die über Erfahrung mit der Wartung von Laufrädern verfügen.

Wenn du als Benutzer:in nicht über die erforderlichen Kenntnisse verfügst, um die in diesem technischen Handbuch beschriebenen Wartungsarbeiten durchzuführen oder die aufgeführten Ersatzteile einzubauen, bringe deine Laufräder bitte zu einer OQUO-Verkaufsstelle. Sie wird die Reparatur bzw. Wartung für dich übernehmen.

Die Kontaktinformationen unseres Händlernetzes findest auf unserer Website:

[www.oquowheels.com](http://www.oquowheels.com)

### WARNUNG

---

Durch nicht fachgerechte Wartungs- oder Reparaturarbeiten verursachte Schäden fallen nicht unter die Gewährleistung.



---

Eine unsachgemäße Reparatur, Wartung oder Montage von Komponenten kann die Integrität und Funktion der Laufräder beeinträchtigen. Das kann zu Unfällen mit schweren Verletzungen oder Todesfolge führen.

---

## DIE VERSCHIEDENEN HANDBÜCHER

### TECHNISCHES HANDBUCH

Dieses Handbuch führt die technischen Daten, Wartungsarbeiten und Original-Ersatzteile für OQUO-Produkte an und richtet sich an den Fachhandel sowie fahrradtechnisch versierte Benutzer:innen.

Zur Wartung der an unseren Laufrädern verbauten Drittanbieterkomponenten wird über Links auf die Dokumentation des jeweiligen Herstellers verwiesen.

Die in diesem Handbuch beschriebenen Vorgehensweisen, technischen Daten und Ersatzteile verstehen sich vorbehaltlich Änderungen unserer Produktspezifikationen.

Die neueste Version dieses technischen Handbuchs ist auf der OQUO-Website verfügbar.

### BEDIENUNGSANLEITUNG

Die Bedienungsanleitung zu unseren Laufrädern, die ausführliche Informationen über den richtigen Gebrauch sowie Warnhinweise zu Nutzung, Transport und Lagerung, Einbau usw. enthält, findest du auf unserer Website.

Die gesamte Dokumentation zu unseren Produkten sowie wichtige Informationen zu Gewährleistung und verfügbaren Wartungsprogrammen steht auf unserer Website zur Verfügung:

[www.oquowheels.com/es-es/soporte/manuales](http://www.oquowheels.com/es-es/soporte/manuales)

---

## ERLÄUTERUNG DER SYMBOLE

In diesem Handbuch werden verschiedene Symbole verwendet, um Anleitungen, Warnhinweise und wichtige Informationen zu Gebrauch, Wartung und Montage zu verdeutlichen. Achte auf diese Symbole, um Gefahrensituationen zu vermeiden und die korrekte Montage und Nutzung sämtlicher Bauteile zu gewährleisten.

Im Folgenden erklären wir die Bedeutung der einzelnen Symbole. In diesem Handbuch wird das Symbol jeweils zusammen mit der für das betroffene Bauteil relevanten Anweisung genutzt. Lies die folgenden Erklärungen aufmerksam durch, um ihre Bedeutung zu verstehen.

### SICHERHEITSANWEISUNGEN



---

**GEFAHR:** Eine gefährliche Situation, die schwere oder tödliche Verletzungen zur Folge hat, wenn sie nicht vermieden wird.



---

**WARNUNG:** Eine gefährliche Situation, die schwere oder tödliche Verletzungen nach sich ziehen kann, wenn sie nicht vermieden wird.



---

**VORSICHT:** Eine gefährliche Situation, die zu leichten bis mittelschweren Verletzungen führen kann, wenn sie nicht gemieden wird.

### WARNUNG

---

Situation, die nicht mit körperlicher Verletzung zusammenhängt. Wichtige Information.

Die Symbole GEFAHR und WARNUNG weisen auf die Gefahr eines Unfalls hin, wenn nicht entsprechende Maßnahmen ergriffen werden, um die beschriebene Situation zu vermeiden. Ein Fahrradunfall birgt immer das Risiko schwerer oder gar tödlicher Verletzungen. In diesem Handbuch wird in Zusammenhang mit diesen Symbolen nicht jedes Mal auf die Gefahr tödlicher Verletzungen hingewiesen, da diese hier ausführlich beschrieben wird.

### WERKZEUGE

Wichtig ist, dass immer die richtigen Werkzeuge und Produkte für die jeweilige Wartung oder Reparatur verwendet werden. Ungeeignete oder schlecht gepflegte Werkzeuge, aber auch die Verwendung von Allzweckprodukten, können Schäden an Komponenten verursachen, die dann nicht unter die Gewährleistung fallen.

Die zu verwendenden Werkzeuge sind in diesem Handbuch angegeben. Bezüglich der an unseren Laufrädern verbauten Komponenten anderer Hersteller wird auch auf die entsprechenden Wartungshandbücher verwiesen, in denen die geeigneten Werkzeuge aufgeführt sind.

---

## ALLGEMEINE WARNHINWEISE IM TECHNISCHEN HANDBUCH

- Einbau- und Wartungsanleitungen sowie Warnhinweise zur Verwendung der an unseren Laufrädern verbauten Drittanbieterkomponenten, wie z. B. Bremsscheiben, Kassetten, Reifen usw., sind der Dokumentation des Komponentenherstellers zu entnehmen.
- Alle Körperteile und Kleidung während der Benutzung oder Einstellung von den Bremsscheiben und Speichen fernhalten, um tiefe Schnitt- und andere Verletzungen zu vermeiden.
- Grundsätzlich sind alle während der Wartung oder Reparatur demontierten Komponenten vor dem Wiedereinbau zu reinigen.
- Die Laufräder und ihre Komponenten müssen sauber und frei von Verunreinigungen gehalten werden, um ihre Funktionsfähigkeit zu gewährleisten und ihren Zustand beurteilen zu können.
- Für die Reinigung von Laufrädern und Komponenten stets ein weiches Tuch und Spezialreiniger verwenden.
- Für die Reinigung von Laufrädern und Laufradteilen keinen Hochdruckreiniger und keine aggressiven Chemikalien verwenden. Durch den Wasserstrahl des Hochdruckreinigers können Schmiermittel verdünnt werden. Dadurch verkürzt sich nicht nur die Wirkdauer der Schmiermittel, sondern es können auch Schäden entstehen, die nicht unter die Gewährleistung fallen.

### ERSATZTEILE

Verwende nur Original-Ersatzteile von OQUO oder solche, die in diesem Handbuch beziehungsweise in der Dokumentation des Komponentenherstellers angegeben sind.

#### WARNUNG

---

Die Verwendung von Nicht-Original-Ersatzteilen kann zu Schäden an Komponenten führen, die nicht durch die Gewährleistung abgedeckt sind.



---

Die Verwendung von Nicht-Original-Ersatzteilen kann zum Versagen von Komponenten führen, was Unfälle und schwere Verletzungen zur Folge haben kann.

## TECHNISCHE DATEN UND MONTAGEINFORMATIONEN FÜR OQUO-LAUFRÄDER

In den folgenden Tabellen sind die technischen Daten der Komponenten und Montageinformationen zu allen OQUO-Modellen detailliert aufgeführt.

Im gesamten Handbuch wird auf die Daten in diesen Tabellen verwiesen, wenn sie für bestimmte Abschnitte relevant sind. Schlage dann in den Tabellen die benötigten Daten nach.

### ÜBERSICHT ÜBER DAS OQUO-MTB-LAUFRADPROGRAMM

	MODELLREIHE	MODELL	KATEGORIE
MTB	MOUNTAIN PERFORMANCE (MP)	MP30LTD	XC, MARATHON, TRAIL
		MP30TEAM	
		MP28PRO	
	MOUNTAIN CONTROL (MC)	MC32LTD	TRAIL, ENDURO, GRAVITY
		MC32LTD POWER	E-ENDURO, GRAVITY
		MC32TEAM	TRAIL, ENDURO, GRAVITY
		MC32TEAM POWER	E-ENDURO, GRAVITY

MOUNTAIN PERFORMANCE (MP)

MP30 LTD (bis MJ 2024)

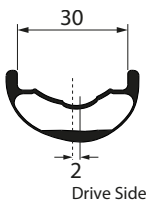
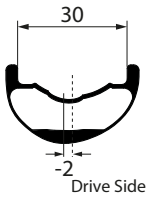
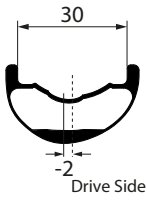
	MODELL	MATERIAL	GRÖSSE	FELGEN-TYP	BREMSEN-TYP	TUBELESS	INNEN-MASS	VERSATZ	DIREKTIONALE SPEICHENLÖCHER	SPEICHEN-LÖCHER	ERD	ETRTO	VERBIN-DUNG	TUBELESS-BANDBREI-TE	VENTIL	KOMPATIBLE REIFEN	MAXIMAL-DRUCK	QUERSCHNITT	
FELGEN	VORDERRAD-FELGE (28-LOCH)	MP10-F-29-28-LOCH	Carbon	29"	Wulst Hookless	Scheibe	JA	30 mm	2 mm	JA	28	611 mm	622 x 30TSS	—	30 mm	44 mm	2,05-2,8 Zoll	**	
	VORDERRAD-FELGE (24H)	MP11-F-29-24-LOCH	Carbon	29"	Wulst Hookless	Scheibe	JA	30 mm	2 mm	JA	24	611 mm	622 x 30TSS	—	30 mm	44 mm	2,05-2,8 Zoll	**	
	HINTERRAD-FELGE	MP10-R-29-28-LOCH	Carbon	29"	Wulst Hookless	Scheibe	JA	30 mm	-2 mm	JA	28	607,6 mm	622 x 30TSS	—	30 mm	44 mm	2,05-2,8 Zoll	**	

	Nein. SPEICHEN	MODELL	SPEICHENMUSTER ANTRIEBSSEITE	SPEICHENMUSTER NICHTANTRIEBSSEITE	SPEICHENLÄNGE ANTRIEBSSEITE	SPEICHENLÄNGE NICHTANTRIEBSSEITE	EINSPEICHSPAN-NUNG ANTRIEBSSEITE	EINSPEICHSPAN-NUNG SCHEIBENSEITE	DRUCKSPEICHE ANTRIEBSSEITE	ZUGSPEICHE ANTRIEBSSEITE	DRUCKSPEICHE NICHTANTRIEBSSEITE	ZUGSPEICHE NICHTANTRIEBSSEITE
SPEICHEN	VORDERRAD (28-LOCH)	Sapim CX-Ray TCS Aero 14G (2 mm) J-Bend	3-fach Kreuzung	3-fach Kreuzung	299 mm	297 mm	—	1200 N	Außen	Innen	Außen	Innen
	VORDERRAD (24H)	Sapim CX-Ray TCS Aero 14G (2 mm) J-Bend	3-fach Kreuzung	3-fach Kreuzung	293 mm	291 mm	—	1200 N	Außen	Innen	Außen	Innen
	HINTERRAD	Sapim CX-Ray TCS Aero 14G (2 mm) J-Bend	3-fach Kreuzung	3-fach Kreuzung	295 mm	296 mm	1300 N	—	Innen	Außen	Außen	Innen

	MODELL	EINBAU-BREITE (OLD)	ACHSE	BREM-SCHEIBEN-TYP	SPEICHEN	FREILAUF-KÖRPER	FREILAUFKÖR-PER-MECHANISMUS
HUB	VORDER-RADNABE (28-LOCH)	DT SWISS 240 Classic CL	Boost 110 mm	Stek-kachse 15 mm	Centre Lock	28 J-Bend	—
	VORDER-RADNABE (24H)	DT SWISS 240 Classic CL	Boost 110 mm	Stek-kachse 15 mm	Centre Lock	24 J-Bend	—
	HINTERRAD-NABE	DT SWISS 240 Classic CL	Boost 148 mm	Stek-kachse 12 mm	Centre Lock	28 J-Bend	Sram XD oder Shimano Microspline Ratchet EXP 36

	MODELL	MASSE	SPEICHENNIP-PEL-UNTERLEGSCH-EBEN	
NIPPLES	VORDER-RAD (28-LOCH)	Sapim Alloy Double Square	2 x 18 mm (14G)	Nein
	VORDER-RAD (24H)	Sapim Alloy Double Square	2 x 18 mm (14G)	Nein
	HINTERRAD	Sapim Alloy Double Square	2 x 18 mm (14G)	Nein

	LAUFRAD	GE-WICHT
WEIGHT	VORDER-RAD (28-LOCH)	625 g +/- 5 %
	VORDER-RAD (24H)	591 g +/- 5 %
	HINTERRAD	730 g +/- 5 %

USE: **ASTM-Kategorie 3** (siehe Bedienungsanleitung)  
Maximalgewicht des Systems (Rad+Fahrer+Ausrüstung) = **110 kg.**

\*\* Angaben zum Maximaldruck für den Reifen findest du in der Bedienungsanleitung oder auf dem Aufkleber auf der Felge.

Für Informationen zu Ersatzteilen klicke oder tippe auf das Naben- oder Speichenmodell

MOUNTAIN PERFORMANCE (MP)

MP30 LTD (ab MJ 2025)

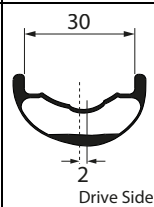
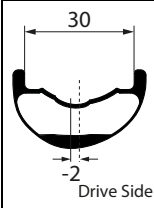
	MODELL	MATERIAL	GRÖSSE	FELGEN-TYP	BREMSEN-TYP	TUBELESS	INNEN-MASS	VERSATZ	DIREKTIONALE SPEICHENLÖCHER	SPEICHEN-LÖCHER	ERD	ETRTO	VERBIN-DUNG	TUBELESS-BANDBREI-TE	VENTIL	KOMPATIBLE REIFEN	MAXIMAL-DRUCK	QUERSCHNITT	
FELGEN	VORDERRAD-FELGE	MP11-F-29-24-LOCH	Carbon	29"	Wulst Hookless	Scheibe	JA	30 mm	2 mm	JA	24	601 mm	622 x 30TSS	—	30 mm	44 mm	2,05-2,8 Zoll	**	
	HINTERRAD-FELGE	MP10-R-29-28-LOCH	Carbon	29"	Wulst Hookless	Scheibe	JA	30 mm	-2 mm	JA	28	599 mm	622 x 30TSS	—	30 mm	44 mm	2,05-2,8 Zoll	**	

	Nein. SPEICHEN	MODELL	SPEICHENMUSTER ANTRIEBSSEITE	SPEICHENMUSTER NICHTANTRIEBSSEITE	SPEICHENLÄNGE ANTRIEBSSEITE	SPEICHENLÄNGE NICHTANTRIEBSSEITE	EINSPEICHSPANNUNG ANTRIEBSSEITE	EINSPEICHSPANNUNG SCHEIBENSEITE	
SPEICHEN	VORDER-RAD (24H)	24	DT Aerolite T-shape SP* 2,0-(0,9 x 2,2)-2 mm	2-fach Kreuzung	2-fach Kreuzung	301 mm	301 mm	—	1200 N
	HINTER-RAD	28	DT Aerolite T-shape SP* 2,0-(0,9 x 2,2)-2 mm	3-fach Kreuzung	3-fach Kreuzung	304 mm	304 mm	1300 N	—

HUB	MODELL	EINBAU-BREITE (OLD)	ACHSE	BREM-SCHIEBEN-TYP	SPEICHEN	FREILAUF-KÖRPER	FREILAUFKÖR- PER-MECHANISMUS	NIPPLES	MODELL	MASSE	SPEICHENNIP- PEL- UNTERLEGSCHEI- BEN	WEIGHT	LAUFRAD	GE- WICHT	USE.
	VORDER-RADNABE	OQUO LTD DT 240 INSIDE	Boost 110 mm	Stek- kachse 15 mm	Centre Lock	24 SP*	—		—	VORDER- RAD	DT Aluminium Double Square		2x15 mm (FG 2,3)	Nein	
HINTERRAD-NABE	OQUO LTD DT 240 INSIDE	Boost 148 mm	Stek- kachse 12 mm	Centre Lock	28 SP*	Sram XD oder SP Shimano Microspline	DT Swiss Ratchet EXP 10° / 36	HINTERRAD	DT Aluminium Double Square	2x15 mm (FG 2,3)	Nein	HINTERRAD	740 g +/- 5 %		

\* SP: Straightpull

\*\* Angaben zum Maximaldruck für den Reifen findest du in der Bedienungsanleitung oder auf dem Aufkleber auf der Felge.

Für Informationen zu Ersatzteilen klicke oder tippe auf das Naben- oder Speichenmodell

MOUNTAIN PERFORMANCE (MP)

MP30 TEAM (bis MJ 2024)

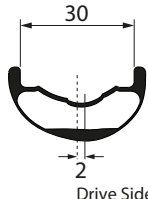
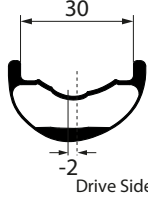
FELGEN		MODELL	MATERIAL	GRÖSSE	FELGEN-TYP	BREMSEN-TYP	TUBELESS	INNEN-MASS	VERSATZ	DIREKTIONALE SPEICHENLÖCHER	SPEICHEN-LÖCHER	ERD	ETRTO	VERBIN-DUNG	TUBELESS-BANDBREITE	VENTIL	KOMPATIBLE REIFEN	MAXIMAL-DRUCK	QUERSCHNITT
	VORDERRAD-FELGE	MP10-F-29-28-LOCH	Carbon	29"	Wulst Hookless	Scheibe	JA	30 mm	2 mm	JA	28	611 mm	622 x 30TSS	—	30 mm	44 mm	2,05-2,8 Zoll	**	
HINTERRAD-FELGE	MP10-R-29-28-LOCH	Carbon	29"	Wulst Hookless	Scheibe	JA	30 mm	-2 mm	JA	28	607,6 mm	622 x 30TSS	—	30 mm	44 mm	2,05-2,8 Zoll	**		

SPEICHEN		Nein. SPEICHEN	MODELL	SPEICHENMUSTER ANTRIEBSSEITE	SPEICHENMUSTER NICHTANTRIEBSSEITE	SPEICHENLÄNGE ANTRIEBSSEITE	SPEICHENLÄNGE NICHTANTRIEBSSEITE	EINSPEICHSPAN-NUNG ANTRIEBSSEITE	EINSPEICHSPAN-NUNG SCHEIBENSEITE	DRUCKSPEICHE ANTRIEBSSEITE	ZUGSPEICHE ANTRIEBSSEITE	DRUCKSPEICHE NICHTAN-TRIEBSSEITE	ZUGSPEICHE NICHTANTRIEBS-SEITE
	VORDERRAD	28	Sapim D-Sprint konifiziert 14G (2 mm) J-Bend	3-fach Kreuzung	3-fach Kreuzung	298 mm	297 mm	—	1200 N	Außen	Innen	Außen	Innen
HINTERRAD	28	Sapim D-Sprint konifiziert 14G (2 mm) J-Bend	3-fach Kreuzung	3-fach Kreuzung	294 mm	295 mm	1300 N	—	Innen	Außen	Außen	Innen	

HUB		MODELL	EINBAU-BREITE (OLD)	ACHSE	BREMS-SCHEIBEN-TYP	SPEICHEN	FREILAUF-KÖRPER	FREILAUFKÖR-PER-MECHANISMUS
	VORDER-RADNABE	DT SWISS 350 Classic CL	Boost 110 mm	Stek-kachse 15 mm	Centre Lock	28 J-Bend	—	—
HINTERRAD-NABE	DT SWISS 350 Classic CL	Boost 148 mm	Stek-kachse 12 mm	Centre Lock	28 J-Bend	Sram XD oder Shimano Microspline	Ratchet 36	

NIPPLES		MODELL	MASSE	SPEICHENNIP-PEL-UNTERLEGSCHEI-BEN
	VORDER-RAD	Sapim Brass Polyax	2 x 14 mm (14G)	Nein
HINTERRAD	Sapim Brass Polyax	2 x 14 mm (14G)	Nein	

WEIGHT		LAUFRAD	GE-WICHT
	VORDER-RAD	700 g +/- 5 %	
HINTERRAD	830 g +/- 5 %		

NUTZUNG		ASTM-Kategorie 3 (siehe Bedienungsanleitung)
	Maximalgewicht des Systems (Rad+Fahrer+Ausrüstung) = <b>110 kg.</b>	

\*\* Angaben zum Maximaldruck für den Reifen findest du in der Bedienungsanleitung oder auf dem Aufkleber auf der Felge.

Für Informationen zu Ersatzteilen klicke oder tippe auf das Naben- oder Speichenmodell

MOUNTAIN PERFORMANCE (MP)

MP30 TEAM (ab MJ 2025)

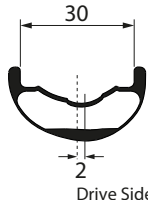
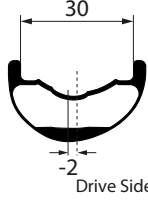
FELGEN		MODELL	MATERIAL	GRÖSSE	FELGEN-TYP	BREMSEN-TYP	TUBELESS	INNEN-MASS	VERSATZ	DIREKTIONALE SPEICHENLÖCHER	SPEICHEN-LÖCHER	ERD	ETRTO	VERBIN-DUNG	TUBELESS-BANDBREITE	VENTIL	KOMPATIBLE REIFEN	MAXIMAL-DRUCK	QUERSCHNITT
	VORDERRAD-FELGE	MP10-F-29-28-LOCH	Carbon	29"	Wulst Hookless	Scheibe	JA	30 mm	2 mm	JA	28	611 mm	622 x 30TSS	—	30 mm	44 mm	2,05-2,8 Zoll	**	
HINTERRAD-FELGE	MP10-R-29-28-LOCH	Carbon	29"	Wulst Hookless	Scheibe	JA	30 mm	-2 mm	JA	28	607,6 mm	622 x 30TSS	—	30 mm	44 mm	2,05-2,8 Zoll	**		

SPEICHEN		Nein. SPEICHEN	MODELL	SPEICHENMUSTER ANTRIEBSSEITE	SPEICHENMUSTER NICHTANTRIEBSSEITE	SPEICHENLÄNGE ANTRIEBSSEITE	SPEICHENLÄNGE NICHTANTRIEBSSEITE	EINSPEICHSPANNUNG ANTRIEBSSEITE	EINSPEICHSPANNUNG SCHEIBENSEITE
	VORDERRAD	28	Sapim Sprint SP* konifiziert 2,0/1,7/2,0	3-fach Kreuzung	3-fach Kreuzung	305 mm	305 mm	—	1200 N
HINTERRAD	28	Sapim Sprint SP* konifiziert 2,0/1,7/2,0	3-fach Kreuzung	3-fach Kreuzung	303 mm	303 mm	1300 N	—	

HUB		MODELL	EINBAU-BREITE (OLD)	ACHSE	BREMSEN-SCHEIBEN-TYP	SPEICHEN	FREILAUF-KÖRPER	FREILAUFKÖRPER-MECHANISMUS	NIPPLES		MODELL	MASSE	SPEICHENNIPPEL-UNTERLEGSCHIEBEN	WEIGHT	LAUFRAD	GE-WICHT	NUTZUNG
	VORDER-RADNABE	OQUO TEAM DT 350 INSIDE	Boost 110 mm	Stek-kachse 15 mm	Centre Lock	28 SP*	—	—		—	VORDER-RAD	Sapim Alloy Double Square	2 x 18 mm (14G)		Nein	VORDER-RAD	
HINTERRAD-NABE	OQUO TEAM DT 350 INSIDE	Boost 148 mm	Stek-kachse 12 mm	Centre Lock	28 SP*	Sram XD oder Shimano Microspline	DT Swiss Ratchet 10° / 36	—	HINTERRAD	Sapim Alloy Double Square	2 x 18 mm (14G)	Nein	HINTERRAD	810g +/- 5 %			

\* SP: Straightpull

\*\* Angaben zum Maximaldruck für den Reifen findest du in der Bedienungsanleitung oder auf dem Aufkleber auf der Felge.

Für Informationen zu Ersatzteilen klicke oder tippe auf das Naben- oder Speichenmodell

MOUNTAIN PERFORMANCE (MP)

MP28 PRO (bis zu MY2023)

FELGEN	MODELL	MATERIAL	GRÖSSE	FELGENTYP	BREMSENTYP	TUBELESS	INNENMASS	VERSATZ	DIREKTIONALE SPEICHENLÖCHER	SPEICHENLÖCHER	ERD	ETRTO	VERBINDUNG	TUBELESSBANDBREITE	VENTIL	KOMPATIBLE REIFEN	MAXIMALDRUCK	QUERSCHNITT
VORDERRAD/ HINTERRAD	MP30-B-29-28-LOCH	Aluminium AL6061	29"	Wulst Hookless	Scheibe	JA	28 mm	2 mm	JA	28	600 mm	622 x 28TSS	Hülle	28 mm	40 mm	2-2,55 Zoll	**	

SPEICHEN	Nein. SPEICHEN	MODELL	SPEICHENMUSTER ANTRIEBSSEITE	SPEICHENMUSTER NICHTANTRIEBSSEITE	SPEICHENLÄNGE ANTRIEBSSEITE	SPEICHENLÄNGE NICHTANTRIEBSSEITE	EINSPEICHSPANNUNG ANTRIEBSSEITE	EINSPEICHSPANNUNG SCHEIBENSEITE	DRUCKSPEICHE ANTRIEBSSEITE	ZUGSPEICHE ANTRIEBSSEITE	DRUCKSPEICHE NICHTANTRIEBSSEITE	ZUGSPEICHE NICHTANTRIEBSSEITE
VORDERRAD	28	Sapim Race konifiziert 14G (2 mm) J-Bend	3-fach Kreuzung	3-fach Kreuzung	298 mm	297 mm	—	1200 N	Außen	Innen	Außen	Innen
HINTERRAD	28	Sapim Race konifiziert 14G (2 mm) J-Bend	3-fach Kreuzung	3-fach Kreuzung	296 mm	297 mm	1200 N	—	Innen	Außen	Außen	Innen

HUB	MODELL	EINBAUBREITE (OLD)	ACHSE	BREMSSCHEIBENTYP	SPEICHEN	FREILAUFKÖRPER	FREILAUFKÖRPERMECHANISMUS
VORDERRADNABE	DT SWISS 350 Classic CL	Boost 110 mm	Stekachse 15 mm	Centre Lock	28 J-Bend	—	—
HINTERRADNABE	DT SWISS 350 Classic CL	Boost 148 mm	Stekachse 12 mm	Centre Lock	28 J-Bend	Sram XD Shimano Microspline Shimano HG	Ratchet 36

NIPPLES	MODELL	MASSE	SPEICHENNIPPEL-UNTERLEGSCHIEBEN
VORDERRAD	Sapim Brass Polyax	2 x 14 mm (14G)	Nein
HINTERRAD	Sapim Brass Polyax	2 x 14 mm (14G)	Nein

WEIGHT	LAUFRAD	GEWICHT
VORDERRAD	850 g +/- 5 %	
HINTERRAD	955 g +/- 5 %	

**NUTZUNG**

**ASTM-Kategorie 4**  
(siehe Bedienungsanleitung)  
Maximalgewicht des Systems (Rad+Fahrer+Ausrüstung) = **110 kg.**

\*\* Angaben zum Maximaldruck für den Reifen findest du in der Bedienungsanleitung oder auf dem Aufkleber auf der Felge.

Für Informationen zu Ersatzteilen klicke oder tippe auf das Naben- oder Speichenmodell

MOUNTAIN PERFORMANCE (MP)

MP28 PRO (von MY2024)

FELGEN	MODELL	MATERIAL	GRÖSSE	FELGEN-TYP	BREMSEN-TYP	TUBE-LESS	INNEN-MASS	VERSATZ	DIREKTIONALE SPEICHENLÖCHER	SPEICHEN-LÖCHER	ERD	ETRTO	VERBIN-DUNG	TUBELESS-BANDBREITE	VENTIL	KOMPATIBLE REIFEN	MAXI-MAL-DRUCK	QUERSCHNITT
VORDERRAD/ HINTERRAD	MP31-B-29-28-LOCH	Aluminium AL6061	29"	Wulst Hookless	Scheibe	JA	28 mm	2 mm	JA	28	600 mm	622 x 28TSS	Hülle	28 mm	40 mm	2-2,55 Zoll	**	

SPEICHEN	Nein. SPEICHEN	MODELL	SPEICHENMUSTER ANTRIEBSSEITE	SPEICHENMUSTER NICHTANTRIEBSSEITE	SPEICHENLÄNGE ANTRIEBSSEITE	SPEICHENLÄNGE NICHTANTRIEBSSEITE	EINSPEICHSPAN-NUNG ANTRIEBSSEITE	EINSPEICHSPAN-NUNG SCHEIBENSEITE	DRUCKSPEICHE ANTRIEBSSEITE	ZUGSPEICHE ANTRIEBSSEITE	DRUCKSPEICHE NICHTANTRIEBSSEITE	ZUGSPEICHE NICHTANTRIEBSSEITE
VORDERRAD	28	Sapim Race konifiziert 14G (2 mm) J-Bend	3-fach Kreuzung	3-fach Kreuzung	297 mm	296 mm	—	1200 N	Außen	Innen	Außen	Innen
HINTERRAD	28	Sapim Race konifiziert 14G (2 mm) J-Bend	3-fach Kreuzung	3-fach Kreuzung	296 mm	296 mm	1200 N	—	Innen	Außen	Außen	Innen

HUB	MODELL	EINBAU-BREITE (OLD)	ACHSE	BREMSEN-TYP	SPEICHEN	FREILAUF-KÖRPER	FREILAUFKÖR- PER-MECHANIS-MUS	NIPPLES	MODELL	MASSE	SPEICHENNIP- PEL- UNTERLEG- SCHEIBEN	WEIGHT	LAUFRAD	GE- WICHT	NUTZUNG
VORDERRAD- NABE	DT SWISS 370 Classic IS	Boost 110 mm	Stek- kachse 15 mm	6-Loch	28 J-Bend	—	—	VORDER- RAD	Sapim Brass Polyax	2 x 14 mm (14G)	Nein	VORDER- RAD	890 g +/- 5 %	<b>ASTM-Kategorie 4</b> (siehe Bedienungsanleitung) Maximalgewicht des Systems (Rad+Fahrer+Ausrüstung) = <b>110 kg.</b>	
HINTERRAD- NABE	DT SWISS 370 Classic IS	Boost 110 mm	Stek- kachse 15 mm	6-Loch	28 J-Bend	Sram XD Shimano Microspline	Ratchet LN 18	HINTERRAD	Sapim Brass Polyax	2 x 14 mm (14G)	Nein	HINTERRAD	1040 g +/- 5 %		

\*\* Angaben zum Maximaldruck für den Reifen findest du in der Bedienungsanleitung oder auf dem Aufkleber auf der Felge.

Für Informationen zu Ersatzteilen klicke oder tippe auf das Naben- oder Speichenmodell

MOUNTAIN CONTROL (MC)

MC32 LTD (bis MJ 2025)

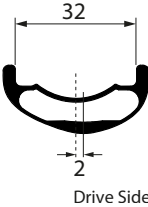
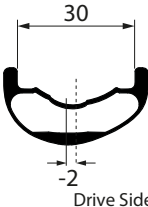
	MODELL	MATERIAL	GRÖSSE	FELGEN-TYP	BREMSEN-TYP	TUBELESS	INNEN-MASS	VERSATZ	DIREKTIONALE SPEICHENLÖCHER	SPEICHEN-LÖCHER	ERD	ETRTO	VERBIN-DUNG	TUBELESS-BANDBREITE	VENTIL	KOMPATIBLE REIFEN	MAXI-MAL-DRUCK	QUERSCHNITT	
FELGEN	VORDERRAD-FELGE	MC10-F-29-28-LOCH	Carbon	29"	Wulst Hookless	Scheibe	JA	32 mm	2 mm	JA	28	604,26 mm	622 x 32TSS	—	32 mm	44 mm	2,4-2,8 Zoll	**	
	HINTERRAD-FELGEN	MC10-R-29-32H	Carbon	29"	Wulst Hookless	Scheibe	JA	30 mm	-2 mm	JA	32	599,86 mm	622 x 30TSS	—	30 mm	44 mm 57 mm beim Wild mit Ventilmagnet	2,05-2,8 Zoll	**	

	Nein. SPEICHEN	MODELL	SPEICHENMUSTER ANTRIEBSSEITE	SPEICHENMUSTER NICHTANTRIEBSSEITE	SPEICHENLÄNGE ANTRIEBSSEITE	SPEICHENLÄNGE NICHTANTRIEBSSEITE	EINSPEICHSPANNUNG ANTRIEBSSEITE	EINSPEICHSPANNUNG SCHEIBENSEITE	DRUCKSPEICHE ANTRIEBSSEITE	ZUGSPEICHE ANTRIEBSSEITE	DRUCKSPEICHE NICHTANTRIEBSSEITE	ZUGSPEICHE NICHTANTRIEBSSEITE
VORDERRAD	28	Sapim D-Sprint konifiziert. 14G (2 mm) J-Bend	3-fach Kreuzung	3-fach Kreuzung	301 mm	298 mm	—	1200 N	Außen	Innen	Außen	Innen
HINTERRAD	32	Sapim D-Sprint konifiziert. 14G (2 mm) J-Bend	3-fach Kreuzung	3-fach Kreuzung	292 mm	292 mm	1300 N	—	Innen	Außen	Außen	Innen

HUB	MODELL	EINBAU-BREITE (OLD)	ACHSE	BREMSSCHEIBEN-TYP	SPEICHEN	FREILAUF-KÖRPER	FREILAUFKÖRPER-MECHANISMUS	NIPPLES	MODELL	MASSE	SPEICHENNIPPEL-UNTERLEGSCHIEBEN	WEIGHT	LAUFRAD	GEWICHT	NUTZUNG
VORDER-RADNABE	DT SWISS 350 Classic IS	Boost 110 mm	Stek-kachse 15 mm	6-Loch	28 J-Bend	—	—	VORDER-RAD	Sapim Brass Polyax	2 x 14 mm (14G)	Nein	VORDER-RAD	860 g +/- 5 %	ASTM-Bedingung 5 (siehe Bedienungsanleitung) Maximalgewicht des Systems (Rad+Fahrer+Ausrüstung) = <b>135 kg.</b>	
HINTERRAD-NABE	DT SWISS 350 Classic IS	Boost 148 mm	Stek-kachse 12 mm	6-Loch	32 J-Bend	Sram XD Shimano MS	Ratchet 36	HINTERRAD	Sapim Brass Polyax	2 x 14 mm (14G)	Nein	HINTERRAD	1042 g +/- 5 %		

\*\* Angaben zum Maximaldruck für den Reifen findest du in der Bedienungsanleitung oder auf dem Aufkleber auf der Felge.

Für Informationen zu Ersatzteilen klicke oder tippe auf das Naben- oder Speichenmodell

MOUNTAIN CONTROL (MC)

MC32 LTD (ab MJ 2026)

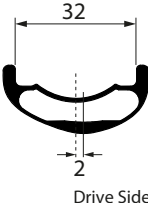
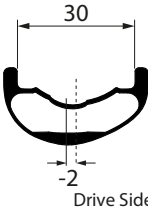
	MODELL	MATERIAL	GRÖSSE	FELGENTYP	BREMSEN-TYP	TUBELESS	INNEN-MASS	VERSATZ	DIREKTIONALE SPEICHENLÖCHER	SPEICHEN-LÖCHER	ERD	ETRT0	VERBIN-DUNG	TUBELESS-BANDBREITE	VENTIL	KOMPATIBLE REIFEN	MAXI-MAL-DRUCK	QUERSCHNITT	
FELGEN	VORDERRAD-FELGE	MC10-F-29-28-LOCH	Carbon	29"	Wulst Hookless	Scheibe	JA	32 mm	2 mm	JA	28	604,26 mm	622 x 32TSS	—	32 mm	44 mm	2,4-2,8 Zoll	**	
	HINTERRAD-FELGEN	MC10-R-29-32H	Carbon	29"	Wulst Hookless	Scheibe	JA	30 mm	-2 mm	JA	32	599,86 mm	622 x 30TSS	—	30 mm	44 mm 57 mm beim Wild mit Ventilmagnet	2,05-2,8 Zoll	**	

	Nein. SPEICHEN	MODELL	SPEICHENMUSTER ANTRIEBSSEITE	SPEICHENMUSTER NICHTANTRIEBSSEITE	SPEICHENLÄNGE ANTRIEBSSEITE	SPEICHENLÄNGE NICHTANTRIEBSSEITE	EINSPEICHSPANNUNG ANTRIEBSSEITE	EINSPEICHSPANNUNG SCHEIBENSEITE	DRUCKSPEICHE ANTRIEBSSEITE	ZUGSPEICHE ANTRIEBSSEITE	DRUCKSPEICHE NICHTANTRIEBSSEITE	ZUGSPEICHE NICHTANTRIEBSSEITE
VORDERRAD	28	Sapim Sprint konifiziert. 14G (2 mm) J-Bend	3-fach Kreuzung	3-fach Kreuzung	299 mm	299 mm	—	1200 N	Außen	Innen	Außen	Innen
HINTERRAD	32	Sapim Race konifiziert 14G (2 mm) J-Bend	3-fach Kreuzung	3-fach Kreuzung	291 mm	291 mm	1300 N	—	Innen	Außen	Außen	Innen

HUB	MODELL	EINBAU-BREITE (OLD)	ACHSE	BREMS-SCHEIBEN-TYP	SPEICHEN	FREILAUF-KÖRPER	FREILAUFKÖRPER-MECHANISMUS
VORDER-RADNABE	OQUO LTD DT 350 INSIDE	Boost 110 mm	Stek-kachse 15 mm	6-Loch	28 J-Bend	—	—
HINTERRAD-NABE	OQUO LTD DT 350 DEG INSIDE	Boost 148 mm	Stek-kachse 12 mm	6-Loch	32 J-Bend	Sram XD Shimano MS	Ratchet DEG 72

NIPPLES	MODELL	MASSE	SPEICHENNIPPEL-UNTERLEGSCHIEBEN
VORDER-RAD	Sapim Brass Polyax	2 x 14 mm (14G)	Nein
HINTERRAD	Sapim Brass Polyax	2 x 14 mm (14G)	Nein

WEIGHT	LAUFRAD	GE-WICHT
VORDER-RAD	VORDER-RAD	860 g +/- 5 %
HINTERRAD	HINTERRAD	1042 g +/- 5 %

**NUTZUNG**

**ASTM-Bedingung 5**  
(siehe Bedienungsanleitung)

Maximalgewicht des Systems (Rad+Fahrer+Ausrüstung) = **135 kg.**

\*\* Angaben zum Maximaldruck für den Reifen findest du in der Bedienungsanleitung oder auf dem Aufkleber auf der Felge.

Für Informationen zu Ersatzteilen klicke oder tippe auf das Naben- oder Speichenmodell

MOUNTAIN CONTROL (MC)

MC32 LTD POWER (bis zu MY2023)

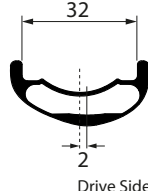
FELGEN	MODELL	MATERIAL	GRÖSSE	FELGENTYP	BREMSENTYP	TUBELESS	INNENBREITE	VERSATZ	DIREKTIONALE SPEICHENLÖCHER	SPEICHENLÖCHER	ERD	ETRTO	VERBINDUNG	TUBELESSBANDBREITE	VENTIL	KOMPATIBLE REIFEN	MAXIMALDRUCK	QUERSCHNITT
HINTERRAD-FELGE	MC10-R-29-32H	Carbon	29"	Wulst Hookless	Scheibe	JA	30 mm	-2 mm	JA	32	599,86 mm	622 x 30TSS	—	30 mm	44 mm 57 mm beim Wild mit Ventilmagnet	2,05-2,8 Zoll	**	

SPEICHEN	Nein. SPEICHEN	MODELL	SPEICHENMUSTER ANTRIEBSSEITE	SPEICHENMUSTER NICHTANTRIEBSSEITE	SPEICHENLÄNGE ANTRIEBSSEITE	SPEICHENLÄNGE NICHTANTRIEBSSEITE	EINSPEICHSPANNUNG ANTRIEBSSEITE	EINSPEICHSPANNUNG SCHEIBENSEITE	DRUCKSPEICHE ANTRIEBSSEITE	ZUGSPEICHE ANTRIEBSSEITE	DRUCKSPEICHE NICHTANTRIEBSSEITE	ZUGSPEICHE NICHTANTRIEBSSEITE
HINTERRAD	32	Sapim E-Light. Konifiziert 14G (2 mm) J-Bend	3-fach Kreuzung	3-fach Kreuzung	292 mm	294 mm	1300 N	—	Innen	Außen	Außen	Innen

HUB	MODELL	EINBAUBREITE (OLD)	ACHSE	BREMSSCHEIBENTYP	SPEICHEN	FREILAUFKÖRPER	FREILAUFKÖRPERMECHANISMUS	NIPPLES	MODELL	MASSE	SPEICHENNIPPEL-UNTERLEG-SCHEIBEN	WEIGHT	LAUFRAD	GEWICHT	NÜTZUNG
HINTERRAD-NABE	DT SWISS 350 Hybrid Classic IS Modell bis MJ 2023	Boost 148 mm	Stekachse 12 mm	6-Loch	32	Sram XD Shimano MS	Ratchet 24	HINTERRAD	Sapim Brass Polyax	2 x 14 mm (14G)	Nein	HINTERRAD	1042 g +/- 5 %	ASTM-Bedingung 5 (siehe Bedienungsanleitung) Maximalgewicht des Systems (Rad+Fahrer +Ausrüstung) = <b>135 kg.</b>	

\*\* Angaben zum Maximaldruck für den Reifen findest du in der Bedienungsanleitung oder auf dem Aufkleber auf der Felge.

Für Informationen zu Ersatzteilen klicke oder tippe auf das Naben- oder Speichenmodell

MOUNTAIN CONTROL (MC)

MC32 LTD POWER (von MY2024)

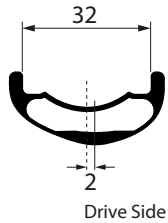
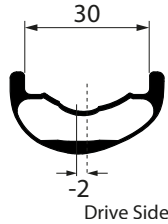
	MODELL	MATERIAL	GRÖSSE	FELGEN-TYP	BREMSEN-TYP	TUBELESS	INNENBREI-TE	VERSATZ	DIREKTIONALE SPEICHENLÖ-CHER	SPEICHEN-LÖCHER	ERD	ETRTO	VERBIN-DUNG	TUBELESS-BANDBREITE	VENTIL	KOMPATIBLE REIFEN	MAXIMAL-DRUCK	QUERSCHNITT	
FELGEN	VORDERRAD-FELGE	MC10-F-29-28-LOCH	Carbon	29"	Wulst Hookless	Scheibe	JA	32 mm	2 mm	JA	28	604,26 mm	622 x 32TSS	—	32 mm	44 mm	2,4-2,8 Zoll	**	
	HINTERRAD-FELGEN	MC10-R-29-32H	Carbon	29"	Wulst Hookless	Scheibe	JA	30 mm	-2 mm	JA	32	599,86 mm	622 x 30TSS	—	30 mm	44 mm 57 mm beim Wild mit Ventilmagnet	2,05-2,8 Zoll	**b	

	Nein. SPEICHEN	MODELL	SPEICHENMUSTER ANTRIEBSSEITE	SPEICHENMUSTER NICHTANTRIEBSSEI-TE	SPEICHENLÄNGE ANTRIEBSSEITE	SPEICHENLÄNGE NICHTANTRIEBS-SEITE	EINSPEICHSPAN-NUNG ANTRIEBSSEITE	EINSPEICHSPAN-NUNG SCHEIBENSEITE	DRUCKSPEICHE ANTRIEBSSEITE	ZUGSPEICHE ANTRIEBSSEITE	DRUCKSPEICHE NICHTAN-TRIEBSSEITE	ZUGSPEICHE NICHTANTRIEBS-SEITE
VORDERRAD	28	Sapim E-Light. Konifiziert 14G (2 mm) J-Bend	3-fach Kreuzung	3-fach Kreuzung	299 mm	298 mm	—	1300 N	Außen	Innen	Außen	Innen
HINTERRAD	32	Sapim E-Light. Konifiziert 14G (2 mm) J-Bend	3-fach Kreuzung	3-fach Kreuzung	291 mm	292 mm	1300 N	—	Innen	Außen	Außen	Innen

HUB	MODELL	EINBAU-BREITE (OLD)	ACHSE	BREM-SCHEIBEN-TYP	SPEICHEN	FREILAUF-KÖRPER	FREILAUFKÖR-PER-MECHANISMUS	NIPPLES	MODELL	MASSE	SPEICHENNIP-PEL-UNTERLEGSCHEI-BEN	WEIGHT	LAUFRAD	GE-WICHT	NUTZUNG
VORDER-RADNABE	DT SWISS 350 Hybrid Classic IS Modell ab MJ 2024	Boost 110 mm	Stek-kachse 15 mm	6-Loch	28	—	—	VORDER-RAD	Sapim Brass Polyax	2 x 14 mm (14G)	Nein	VORDER-RAD	910 g +/- 5 %	<b>ASTM-Bedingung 5</b> (siehe Bedienungsanleitung) Maximalgewicht des Systems (Rad+Fahrer+Ausrüstung) = <b>135 kg.</b>	
HINTERRAD-NABE	DT SWISS 350 Hybrid Classic IS Modell ab MJ 2024	Boost 148 mm	Stek-kachse 12 mm	6-Loch	32	Sram XD Shimano MS	Ratchet 24	HINTERRAD	Sapim Brass Polyax	2 x 14 mm (14G)	Nein	HINTERRAD	1056 g +/- 5 %		

\*\* Angaben zum Maximaldruck für den Reifen findest du in der Bedienungsanleitung oder auf dem Aufkleber auf der Felge.

Für Informationen zu Ersatzteilen klicke oder tippe auf das Naben- oder Speichenmodell

MOUNTAIN CONTROL (MC)

MC32 TEAM (bis MJ 2024)

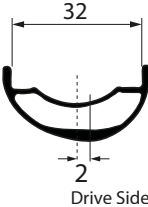
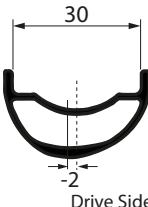
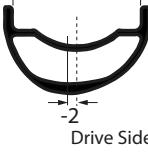
FELGEN		MODELL	MATERIAL	GRÖSSE	FELGENTYP	BREMSENTYP	TUBELESS	INNENMASS	VERSATZ	DIREKTIONALE SPEICHENLÖCHER	SPEICHENLÖCHER	ERD	ETRTO	VERBINDUNG	TUBELESS-BANDBREITE	VENTIL	KOMPATIBLE REIFEN	MAXIMALDRUCK	QUERSCHNITT
	29" VORDERRADFELGE	MC30-F-29-28-LOCH	Aluminium AL6061	29"	Wulst Hookless	Scheibe	JA	32 mm	2 mm	JA	28	604 mm	622 x 32TSS	Hülle	32 mm	44 mm	2,4-2,8 Zoll	**	
	29" HINTERRADFELGE	MC30-R-29-32H	Aluminium AL6061	29"	Wulst Hookless	Scheibe	JA	30 mm	-2 mm	JA	32	600 mm	622 x 30TSS	Hülle	30 mm	44 mm 57 mm beim Wild mit Ventilmagnet	2,05-2,8 Zoll	**	
	27,5" HINTERRADFELGE	MC31-R-27-32H	Aluminium AL6061	27,5"	Wulst Hookless	Scheibe	JA	30 mm	-2 mm	JA	32	561,6 mm	584 x 30TSS	Hülle	30 mm	44 mm 57 mm beim Wild mit Ventilmagnet	2,05-2,8 Zoll	**	

SPEICHEN		Nein. SPEICHEN	MODELL	SPEICHENMUSTER ANTRIEBSSEITE	SPEICHENMUSTER NICHTANTRIEBSSEITE	SPEICHENLÄNGE ANTRIEBSSEITE	SPEICHENLÄNGE NICHTANTRIEBSSEITE	EINSPEICHSPANNUNG ANTRIEBSSEITE	EINSPEICHSPANNUNG SCHEIBENSEITE	DRUCKSPEICHE ANTRIEBSSEITE	ZUGSPEICHE ANTRIEBSSEITE	DRUCKSPEICHE NICHTANTRIEBSSEITE	ZUGSPEICHE NICHTANTRIEBSSEITE
	29" VORDERRAD	28	Sapim D-Sprint Konifiziert. 14G (2 mm). J-Bend	3-fach Kreuzung	3-fach Kreuzung	299 mm	297 mm	—	1200 N	Außen	Innen	Außen	Innen
	29" HINTERRAD	32	Sapim Race Konifiziert. 14G (2 mm). J-Bend	3-fach Kreuzung	3-fach Kreuzung	291 mm	291 mm	1200 N	—	Innen	Außen	Außen	Innen
	27,5" HINTERRAD	32	Sapim Race Konifiziert. 14G (2 mm). J-Bend	3-fach Kreuzung	3-fach Kreuzung	271 mm	271 mm	1200 N	—	Innen	Außen	Außen	Innen

HUB		MODELL	EINBAUBREITE (OLD)	ACHSE	BREMS-SCHEIBENTYP	SPEICHEN	FREILAUFKÖRPER	FREILAUFKÖRPER-MECHANISMUS
	29" VORDERRAD	DT SWISS 350 Classic IS	Boost 110 mm	Stekachse 15 mm	6-Loch	28 J-Bend	—	—
	29" HINTERRAD	DT SWISS 350 Classic IS	Boost 148 mm	Stekachse 12 mm	6-Loch	32 J-Bend	Sram XD oder Shimano MS	Ratchet 36
	27,5" HINTERRAD	DT SWISS 350 Classic IS	Boost 148 mm	Stekachse 12 mm	6-Loch	32 J-Bend	Sram XD oder Shimano MS	Ratchet 36

NIPPLES		MODELL	MASSE	SPEICHENNIPPEL-UNTERLEGSCHIEBEN
	29" VORDERRAD	Sapim Brass Polyax	2 x 14 mm (14G)	Nein
	29" HINTERRAD	Sapim Brass Polyax	2 x 14 mm (14G)	Nein
	27,5" HINTERRAD	Sapim Brass Polyax	2 x 14 mm (14G)	Nein

WEIGHT		LAUFRAD	GEWICHT
	29" VORDERRAD	898 g +/- 5 %	
	29" HINTERRAD	1046 g +/- 5 %	
	27,5" HINTERRAD	1010 g +/- 5 %	

**NUTZUNG**

**ASTM-Bedingung 5**  
(siehe Bedienungsanleitung)

Maximalgewicht des Systems (Rad+Fahrer+Ausrüstung) = **135 kg.**

MOUNTAIN CONTROL (MC)

MC32 TEAM (MJ 2025)

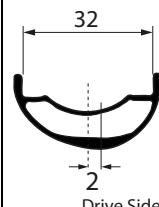
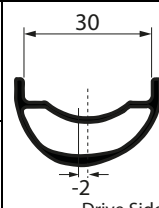
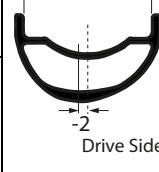
FELGEN		MODELL	MATERIAL	GRÖSSE	FELGENTYP	BREMSENTYP	TUBELESS	INNENMASS	VERSATZ	DIREKTIONALE SPEICHENLÖCHER	SPEICHENLÖCHER	ERD	ETRTO	VERBINDUNG	TUBELESS-BANDBREITE	VENTIL	KOMPATIBLE REIFEN	MAXIMAL-DRUCK	QUERSCHNITT
	29" VORDERRADFELGE	MC36-F-29-28-LOCH	Aluminium AL6061	29"	Wulst Hookless	Scheibe	JA	32 mm	2 mm	JA	28	612,3 mm	622 x 32TSS	Hülle	32 mm	44 mm	2,4-2,8 Zoll	**	
	29" HINTERRADFELGE	MC36-R-29-32-Loch	Aluminium AL6061	29"	Wulst Hookless	Scheibe	JA	30 mm	-2 mm	JA	32	610,9 mm	622 x 30TSS	Hülle	30 mm	44 mm Wild beim Wild mit Ventilmagnet	2,05-2,8 Zoll	**	
	27,5" HINTERRADFELGE	MC37-R-27-32-Loch	Aluminium AL6061	27,5"	Wulst Hookless	Scheibe	JA	30 mm	-2 mm	JA	32	572,9 mm	584 x 30TSS	Hülle	30 mm	44 mm Wild beim Wild mit Ventilmagnet	2,05-2,8 Zoll	**	

SPEICHEN		Nein. SPEICHEN	MODELL	SPEICHENMUSTER ANTRIEBSSEITE	SPEICHENMUSTER NICHTANTRIEBSSEITE	SPEICHENLÄNGE ANTRIEBSSEITE	SPEICHENLÄNGE NICHTANTRIEBSSEITE	EINSPEICHSPANNUNG ANTRIEBSSEITE	EINSPEICHSPANNUNG SCHEIBENSEITE	DRUCKSPEICHE ANTRIEBSSEITE	ZUGSPEICHE ANTRIEBSSEITE	DRUCKSPEICHE NICHTANTRIEBSSEITE	ZUGSPEICHE NICHTANTRIEBSSEITE
	29" VORDERRAD	28	Sapim D-Light Konifiziert. 14G (2 mm). J-Bend	3-fach Kreuzung	3-fach Kreuzung	302 mm	300 mm.	—	1300 N	Außen	Innen	Außen	Innen
	29" HINTERRAD	32	Sapim Sprint Konifiziert. 14G (2 mm). J-Bend	3-fach Kreuzung	3-fach Kreuzung	295 mm	295 mm	1300 N	—	Innen	Außen	Außen	Innen
	27,5" HINTERRAD	32	Sapim Sprint Konifiziert. 14G (2 mm). J-Bend	3-fach Kreuzung	3-fach Kreuzung	276 mm	276 mm	1300 N	—	Innen	Außen	Außen	Innen

HUB		MODELL	EINBAUBREITE (OLD)	ACHSE	BREMS-SCHEIBENTYP	SPEICHEN	FREILAUFKÖRPER	FREILAUFKÖRPER-MECHANISMUS
	29" VORDERRAD	DT SWISS 350 Classic IS	Boost 110 mm	Stek-kachse 15 mm	6-Loch	28 J-Bend	—	—
	29" HINTERRAD	DT SWISS 350 Classic IS	Boost 148 mm	Stek-kachse 12 mm	6-Loch	32 J-Bend	Sram XD oder Shimano MS	Ratchet 36
	27,5" HINTERRAD	DT SWISS 350 Classic IS	Boost 148 mm	Stek-kachse 12 mm	6-Loch	32 J-Bend	Sram XD oder Shimano MS	Ratchet 36

NIPPLES		MODELL	MASSE	SPEICHENNIPPEL-UNTERLEGSCHNEIBEN
	29" VORDERRAD	Sapim Alloy Double Square	2 x 18 mm (14G)	Nein
	29" HINTERRAD	Sapim Alloy Double Square	2 x 18 mm (14G)	Nein
	27,5" HINTERRAD	Sapim Alloy Double Square	2 x 18 mm (14G)	Nein

WEIGHT		LAUFRAD	GEWICHT
	29" VORDERRAD	29" VORDERRAD	970 g +/- 5 %
	29" HINTERRAD	29" HINTERRAD	1108 g +/- 5 %
	27,5" HINTERRAD	27,5" HINTERRAD	1055 g +/- 5 %

**NUTZUNG**

**ASTM-Bedingung 5**  
(siehe Bedienungsanleitung)

Maximalgewicht des Systems (Rad+Fahrer+Ausrüstung) = **135 kg.**

MOUNTAIN CONTROL (MC)

MC32 TEAM (ab MJ 2026)

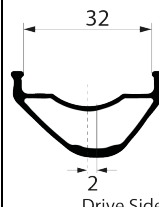
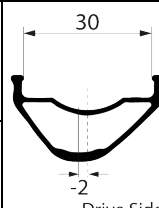
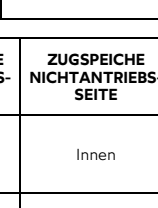
FELGEN		MODELL	MATERIAL	GRÖSSE	FELGENTYP	BREMSEN-TYP	TUBELESS	INNEN-MASS	VERSATZ	DIREKTIONALE SPEICHENLÖCHER	SPEICHEN-LÖCHER	ERD	ETRTO	VERBIN-DUNG	TUBELESS-BANDBREI-TE	VENTIL	KOMPATIBLE REIFEN	MAXIMAL-DRUCK	QUERSCHNITT
	29" VORDERRADFEL-GE	MC36-F-29-28-LOCH	Aluminium AL6061	29"	Wulst Minihook	Scheibe	JA	32 mm	2 mm	JA	28	612,3 mm	622 x 32TSS	Hülle	32 mm	44 mm	2,4-2,8 Zoll	**	
	29" HINTERRADFEL-GE	MC36-R-29-32-Loch	Aluminium AL6061	29"	Wulst Minihook	Scheibe	JA	30 mm	-2 mm	JA	32	610,9 mm	622 x 30TSS	Hülle	30 mm	44 mm 57 mm beim Wild mit Ventilma- gnet	2,05-2,8 Zoll	**	
	27,5" HINTERRADFEL-GE	MC37-R-27-32-Loch	Aluminium AL6061	27,5"	Wulst Minihook	Scheibe	JA	30 mm	-2 mm	JA	32	572,9 mm	584 x 30TSS	Hülle	30 mm	44 mm 57 mm beim Wild mit Ventilma- gnet	2,05-2,8 Zoll	**	

SPEICHEN		Nein. SPEICHEN	MODELL	SPEICHENMUSTER ANTRIEBSSEITE	SPEICHENMUSTER NICHTANTRIEBSSEI-TE	SPEICHENLÄNGE ANTRIEBSSEITE	SPEICHENLÄNGE NICHTANTRIEBSSEI-TE	EINSPEICHSPAN-NUNG ANTRIEBSSEITE	EINSPEICHSPAN-NUNG SCHEIBENSEITE	DRUCKSPEICHE ANTRIEBSSEITE	ZUGSPEICHE ANTRIEBSSEITE	DRUCKSPEICHE NICHTANTRIEBS-SEITE	ZUGSPEICHE NICHTANTRIEBS-SEITE
	29" VORDERRAD	28	Sapim D-Light Konifiziert. 14G (2 mm). J-Bend	3-fach Kreuzung	3-fach Kreuzung	298 mm	297 mm	—	1300 N	Außen	Innen	Außen	Innen
	29" HINTERRAD	32	Sapim Sprint Konifiziert. 14G (2 mm). J-Bend	3-fach Kreuzung	3-fach Kreuzung	291 mm	291 mm	1300 N	—	Innen	Außen	Außen	Innen
	27,5" HINTERRAD	32	Sapim Sprint Konifiziert. 14G (2 mm). J-Bend	3-fach Kreuzung	3-fach Kreuzung	272 mm	272 mm	1300 N	—	Innen	Außen	Außen	Innen

HUB		MODELL	EINBAU-BREITE (OLD)	ACHSE	BREMS-SCHEIBEN-TYP	SPEICHEN	FREILAUF-KÖRPER	FREILAUFKÖR-PER-MECHANISMUS
	29" VORDER-RAD	OQUO LTD DT 350 INSIDE	Boost 110 mm	Stek-kachse 15 mm	6-Loch	28 J-Bend	—	—
	29" HINTERRAD	OQUO LTD DT 350 DEG INSIDE	Boost 148 mm	Stek-kachse 12 mm	6-Loch	32 J-Bend	Sram XD oder Shimano MS	Ratchet DEG 72
	27,5" HINTERRAD	OQUO LTD DT 350 DEG INSIDE	Boost 148 mm	Stek-kachse 12 mm	6-Loch	32 J-Bend	Sram XD oder Shimano MS	Ratchet DEG 72

NIPPLES		MODELL	MASSE	SPEICHENNIP-PEL-UNTERLEGSCHEI-BEN
	29" VORDER-RAD	Sapim Alloy Double Square	2 x 18 mm (14G)	Nein
	29" HINTERRAD	Sapim Alloy Double Square	2 x 18 mm (14G)	Nein
	27,5" HINTERRAD	Sapim Alloy Double Square	2 x 18 mm (14G)	Nein

WEIGHT		LAUFRAD	GE-WICHT
	29" VORDER-RAD	29" VORDER-RAD	950 g +/- 5 %
	29" HINTERRAD	29" HINTERRAD	1125 g +/- 5 %
	27,5" HINTERRAD	27,5" HINTERRAD	1075 g +/- 5 %

**NUTZUNG**

**ASTM-Bedingung 5**  
(siehe Bedienungsanleitung)

Maximalgewicht des Systems (Rad+Fahrer+Ausrüstung) = **135 kg.**

MOUNTAIN CONTROL (MC)

MC32 TEAM RALLON DH MJ 2026 (OEM)

WARNUNG

Dieser MC32 TEAM Laufradsatz ist nur an Orbea Rallon DH MJ 2026 Komplettbike-Aufbauten erhältlich.

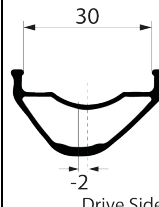
FELGEN	MODELL	MATERIAL	GRÖSSE	FELGENTYP	BREMSENTYP	TUBELESS	INNENMASS	VERSATZ	DIREKTIONALE SPEICHENLÖCHER	SPEICHENLÖCHER	ERD	ETRTO	VERBINDUNG	TUBELESSBANDBREITE	VENTIL	KOMPATIBLE REIFEN	MAXIMALDRUCK	QUERSCHNITT
	29" VORDERRADFELGE	MC36-F-29-28-LOCH	Aluminium AL6061	29"	Wulst Minihook	Scheibe	JA	32 mm	2 mm	JA	28	612,3 mm	622 x 32TSS	Hülle	32 mm	44 mm	2,4-2,8 Zoll	**
27,5" HINTERRADFELGE	MC37-R-27-32-Loch	Aluminium AL6061	27,5"	Wulst Minihook	Scheibe	JA	30 mm	-2 mm	JA	32	572,9 mm	584 x 30TSS	Hülle	30 mm	44 mm 57 mm beim Wild mit Ventilmagnet	2,05-2,8 Zoll	**	

SPEICHEN	Nein. SPEICHEN	MODELL	SPEICHENMUSTER ANTRIEBSSEITE	SPEICHENMUSTER NICHTANTRIEBSSEITE	SPEICHENLÄNGE ANTRIEBSSEITE	SPEICHENLÄNGE NICHTANTRIEBSSEITE	EINSPEICHSPANNUNG ANTRIEBSSEITE	EINSPEICHSPANNUNG SCHEIBENSEITE	DRUCKSPEICHE ANTRIEBSSEITE	ZUGSPEICHE ANTRIEBSSEITE	DRUCKSPEICHE NICHTANTRIEBSSEITE	ZUGSPEICHE NICHTANTRIEBSSEITE
	29" VORDERRAD	28	Sapim Race Konifiziert. 14G (2 mm). J-Bend	3-fach Kreuzung	3-fach Kreuzung	296 mm	296 mm	—	1300 N	Außen	Innen	Außen
27,5" HINTERRAD	32	Sapim Race Konifiziert. 14G (2 mm). J-Bend	3-fach Kreuzung	3-fach Kreuzung	272 mm	272 mm	1300 N	—	Innen	Außen	Außen	Innen

HUB	MODELL	EINBAUBREITE (OLD)	ACHSE	BREMS-SCHEIBENTYP	SPEICHEN	FREILAUFKÖRPER	FREILAUFKÖRPER-MECHANISMUS	NIPPLES	MODELL	MASSE	SPEICHENNIPPEL-UNTERLEGSCHNEIBEN	WEIGHT	LAUFRAD	GEWICHT	NUTZUNG
	29" VORDERRAD	DT SWISS 350 Classic IS	Boost 110 mm	Stekachse 20 mm	6-Loch	28 J-Bend	—		—	29" VORDERRAD	Sapim Brass Polyax		2 x 14 mm (14G)	Nein	
27,5" HINTERRAD	DT SWISS 350 Classic IS	Boost 148 mm	Stekachse 12 mm	6-Loch	32 J-Bend	Shimano HG	Ratchet 36 SL	27,5" HINTERRAD	Sapim Brass Polyax	2 x 14 mm (14G)	Nein	27,5" HINTERRAD	1055 g +/- 5 %		

**ASTM-Bedingung 5**  
(siehe Bedienungsanleitung)  
Maximalgewicht des Systems (Rad+Fahrer+Ausrüstung) = **135 kg.**

MOUNTAIN CONTROL (MC)

MC32 TEAM POWER (bis zu MY2023)

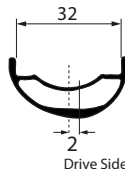
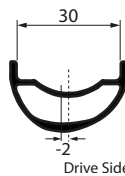
	MODELL	MATERIAL	GRÖSSE	FELGENTYP	BREMSEN-TYP	TUBELESS	INNENBREITE	VERSATZ	DIREKTIONALE SPEICHENLÖCHER	SPEICHENLÖCHER	ERD	ETRTO	VERBINDUNG	TUBELESS-BANDBREITE	VENTIL	KOMPATIBLE REIFEN	MAXIMAL-DRUCK	QUERSCHNITT	
FELGEN	VORDERRAD-FELGE	MC31-F-29-32-LOCH	Aluminium AL6061	29"	Wulst Hookless	Scheibe	JA	32 mm	2 mm	JA	32	604 mm	622 x 32TSS	Hülle	32 mm	44 mm	2,4-2,8 Zoll	**	
	HINTERRAD-FELGE	MC30-R-29-32H	Aluminium AL6061	29"	Wulst Hookless	Scheibe	JA	30 mm	-2 mm	JA	32	600 mm	622 x 30TSS	Hülle	30 mm	44 mm 57 mm beim Wild mit Ventilmagnet	2,05-2,8 Zoll	**	

	Nein. SPEICHEN	MODELL	SPEICHENMUSTER ANTRIEBSSEITE	SPEICHENMUSTER NICHTANTRIEBSSEITE	SPEICHENLÄNGE ANTRIEBSSEITE	SPEICHENLÄNGE NICHTANTRIEBSSEITE	EINSPEICHSPANNUNG ANTRIEBSSEITE	EINSPEICHSPANNUNG SCHEIBENSEITE	DRUCKSPEICHE ANTRIEBSSEITE	ZUGSPEICHE ANTRIEBSSEITE	DRUCKSPEICHE NICHTANTRIEBSSEITE	ZUGSPEICHE NICHTANTRIEBSSEITE
VORDERRAD	32	Sapim E-Light. Konifiziert 14G (2 mm) J-Bend	3-fach Kreuzung	3-fach Kreuzung	294 mm	292 mm	—	1200 N	Außen	Innen	Außen	Innen
HINTERRAD	32	Sapim E-Light. Konifiziert 14G (2 mm) J-Bend	3-fach Kreuzung	3-fach Kreuzung	291 mm	293 mm	1200 N	—	Innen	Außen	Außen	Innen

HUB	MODELL	EINBAUBREITE (OLD)	ACHSE	BREMSSCHEIBENTYP	SPEICHEN	FREILAUFKÖRPER	FREILAUFKÖRPER-MECHANISMUS	NIPPLES	MODELL	MASSE	SPEICHENNIPPEL-UNTERLEGSCHNEIBEN	LAUFRAD	GEWICHT	NUTZUNG
VORDER-RADNABE	DT SWISS 350 Hybrid Classic IS Modell bis MJ 2023	Boost 110 mm	Stekachse 15 mm	6-Loch	32	—	—	VORDER-RAD	Sapim Brass Polyax	2 x 14 mm (14G)	Nein	VORDER-RAD	930 g +/- 5 %	<b>ASTM-Bedingung 5</b> (siehe Bedienungsanleitung) Maximalgewicht des Systems (Rad+Fahrer+Ausrüstung) = <b>135 kg.</b>
HINTERRAD-NABE	DT SWISS 350 Hybrid Classic IS Modell bis MJ 2023	Boost 148 mm	Stekachse 12 mm	6-Loch	32	Sram XD Shimano MS	Ratchet 24	HINTERRAD	Sapim Brass Polyax	2 x 14 mm (14G)	Nein	HINTERRAD	1060 g +/- 5 %	

\*\* Angaben zum Maximaldruck für den Reifen findest du in der Bedienungsanleitung oder auf dem Aufkleber auf der Felge.

Für Informationen zu Ersatzteilen klicke oder tippe auf das Naben- oder Speichenmodell

MOUNTAIN CONTROL (MC)

MC32 TEAM POWER (MJ 2024)

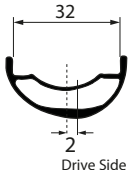
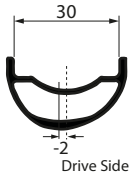
FELGEN		MODELL	MATERIAL	GRÖSSE	FELGENTYP	BREMSEN-TYP	TUBELESS	INNEN-MASS	VERSATZ	DIREKTIONALE SPEICHENLÖCHER	SPEICHENLÖCHER	ERD	ETRTO	VERBUNDUNG	TUBELESS-BANDBREITE	VENTIL	KOMPATIBLE REIFEN	MAXIMAL-DRUCK	QUERSCHNITT
	29" VORDERRAD-FELGE	MC30-F-29-28-LOCH	Aluminium AL6061	29"	Wulst Hookless	Scheibe	JA	32 mm	2 mm	JA	28	604 mm	622 x 32TSS	Hülle	32 mm	44 mm	2,4-2,8 Zoll	**	
	29" HINTERRAD-FELGE	MC30-R-29-32H	Aluminium AL6061	29"	Wulst Hookless	Scheibe	JA	30 mm	-2 mm	JA	32	600 mm	622 x 30TSS	Hülle	30 mm	44 mm 57 mm beim Wild mit Ventilmagnet	2,05-2,8 Zoll	**	
	27,5" HINTERRAD-FELGE	MC31-R-27-32H	Aluminium AL6061	27,5"	Wulst Hookless	Scheibe	JA	30 mm	-2 mm	JA	32	561,6 mm	584 x 30TSS	Hülle	30 mm	44 mm 57 mm beim Wild mit Ventilmagnet	2,05-2,8 Zoll	**	

SPEICHEN		Nein. SPEICHEN	MODELL	SPEICHENMUSTER ANTRIEBSSEITE	SPEICHENMUSTER NICHTANTRIEBSSEITE	SPEICHENLÄNGE ANTRIEBSSEITE	SPEICHENLÄNGE NICHTANTRIEBSSEITE	EINSPEICHSPANNUNG ANTRIEBSSEITE	EINSPEICHSPANNUNG SCHEIBENSEITE	DRUCKSPEICHE ANTRIEBSSEITE	ZUGSPEICHE ANTRIEBSSEITE	DRUCKSPEICHE NICHTANTRIEBSSEITE	ZUGSPEICHE NICHTANTRIEBSSEITE
	29" VORDERRAD	28	Sapim E-Light. Konifiziert 14G (2 mm) J-Bend	3-fach Kreuzung	3-fach Kreuzung	298 mm	297 mm	—	1200 N	Außen	Innen	Außen	Innen
	29" HINTERRAD	32	Sapim E-Light. Konifiziert 14G (2 mm) J-Bend	3-fach Kreuzung	3-fach Kreuzung	291 mm	292 mm	1200 N	—	Innen	Außen	Außen	Innen
	27,5" HINTERRAD	32	Sapim E-Light. Konifiziert 14G (2 mm) J-Bend	3-fach Kreuzung	3-fach Kreuzung	271 mm	271 mm	1200 N	—	Innen	Außen	Außen	Innen

HUB		MODELL	EINBAU-BREITE (OLD)	ACHSE	BREMS-SCHEIBENTYP	SPEICHEN	FREILAUF-KÖRPER	FREILAUFKÖRPER-MECHANISMUS
	29" VORDER-RAD	DT SWISS 350 Hybrid Classic IS Modell ab MJ 2024	Boost 110 mm	Stek-kachse 15 mm	6-Loch	28 J-Bend	—	—
	29" HINTERRAD	DT SWISS 350 Hybrid Classic IS Modell ab MJ 2024	Boost 148 mm	Stek-kachse 12 mm	6-Loch	32 J-Bend	Sram XD oder Shimano MS	Ratchet 24
	27,5" HINTERRAD	DT SWISS 350 Hybrid Classic IS Modell ab MJ 2024	Boost 148 mm	Stek-kachse 12 mm	6-Loch	32 J-Bend	Sram XD oder Shimano MS	Ratchet 24

NIPPLES		MODELL	MASSE	SPEICHENNIPPEL-UNTERLEGSCHNEIBEN
	29" VORDER-RAD	Sapim Brass Polyax	2 x 14 mm (14G)	Nein
	29" HINTERRAD	Sapim Brass Polyax	2 x 14 mm (14G)	Nein
	27,5" HINTERRAD	Sapim Brass Polyax	2 x 14 mm (14G)	Nein

WEIGHT		LAUFRAD	GEWICHT
	29" VORDER-RAD	29" VORDER-RAD	985 g +/- 5 %
	29" HINTERRAD	29" HINTERRAD	1160 g +/- 5 %
	27,5" HINTERRAD	27,5" HINTERRAD	1085 g +/- 5 %

**NUTZUNG**

**ASTM-Bedingung 5**  
(siehe Bedienungsanleitung)

Maximalgewicht des Systems (Rad+Fahrer+Ausrüstung) = **135 kg.**

MOUNTAIN CONTROL (MC)

MC32 TEAM POWER (MJ 2025)

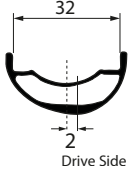
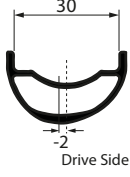
FELGEN		MODELL	MATERIAL	GRÖSSE	FELGENTYP	BREMSEN-TYP	TUBELESS	INNEN-MASS	VERSATZ	DIREKTIONALE SPEICHENLÖCHER	SPEICHENLÖCHER	ERD	ETRTO	VERBUNDUNG	TUBELESS-BANDBREITE	VENTIL	KOMPATIBLE REIFEN	MAXIMAL-DRUCK	QUERSCHNITT
	29" VORDERRAD-FELGE	MC36-F-29-28-LOCH	Aluminium AL6061	29"	Wulst Hookless	Scheibe	JA	32 mm	2 mm	JA	28	612,3 mm	622 x 32TSS	Hülle	32 mm	44 mm	2,4-2,8 Zoll	**	
	29" HINTERRAD-FELGE	MC36-R-29-32-Loch	Aluminium AL6061	29"	Wulst Hookless	Scheibe	JA	30 mm	-2 mm	JA	32	610,9 mm	622 x 30TSS	Hülle	30 mm	44 mm 57 mm beim Wild mit Ventilmagnet	2,05-2,8 Zoll	**	
	27,5" HINTERRAD-FELGE	MC37-R-27-32-Loch	Aluminium AL6061	27,5"	Wulst Hookless	Scheibe	JA	30 mm	-2 mm	JA	32	572,9 mm	584 x 30TSS	Hülle	30 mm	44 mm 57 mm beim Wild mit Ventilmagnet	2,05-2,8 Zoll	**	

SPEICHEN		Nein. SPEICHEN	MODELL	SPEICHENMUSTER ANTRIEBSSEITE	SPEICHENMUSTER NICHTANTRIEBSSEITE	SPEICHENLÄNGE ANTRIEBSSEITE	SPEICHENLÄNGE NICHTANTRIEBSSEITE	EINSPEICHSPANNUNG ANTRIEBSSEITE	EINSPEICHSPANNUNG SCHEIBENSEITE	DRUCKSPEICHE ANTRIEBSSEITE	ZUGSPEICHE ANTRIEBSSEITE	DRUCKSPEICHE NICHTANTRIEBSSEITE	ZUGSPEICHE NICHTANTRIEBSSEITE
	29" VORDERRAD	28	Sapim E-Light. Konifiziert 14G (2 mm) J-Bend	3-fach Kreuzung	3-fach Kreuzung	301 mm	300 mm.	—	1300 N	Außen	Innen	Außen	Innen
	29" HINTERRAD	32	Sapim E-Light. Konifiziert 14G (2 mm) J-Bend	3-fach Kreuzung	3-fach Kreuzung	294 mm	295 mm	1300 N	—	Innen	Außen	Außen	Innen
	27,5" HINTERRAD	32	Sapim E-Light. Konifiziert 14G (2 mm) J-Bend	3-fach Kreuzung	3-fach Kreuzung	275 mm	276 mm	1300 N	—	Innen	Außen	Außen	Innen

HUB		MODELL	EINBAU-BREITE (OLD)	ACHSE	BREMS-SCHEIBENTYP	SPEICHEN	FREILAUF-KÖRPER	FREILAUFKÖRPER-MECHANISMUS
	29" VORDER-RAD	DT SWISS 350 Hybrid Classic IS Modell ab MJ 2024	Boost 110 mm	Stek-kachse 15 mm	6-Loch	28 J-Bend	—	—
	29" HINTERRAD	DT SWISS 350 Hybrid Classic IS Modell ab MJ 2024	Boost 148 mm	Stek-kachse 12 mm	6-Loch	32 J-Bend	Sram XD oder Shimano MS	10 ° Ratchet 32
	27,5" HINTERRAD	DT SWISS 350 Hybrid Classic IS Modell ab MJ 2024	Boost 148 mm	Stek-kachse 12 mm	6-Loch	32 J-Bend	Sram XD oder Shimano MS	10 ° Ratchet 32

NIPPLES		MODELL	MASSE	SPEICHENNIPPEL-UNTERLEGSCHNEIBEN
	29" VORDER-RAD	Sapim Alloy Double Square	2 x 18 mm (14G)	Nein
	29" HINTERRAD	Sapim Alloy Double Square	2 x 18 mm (14G)	Nein
	27,5" HINTERRAD	Sapim Alloy Double Square	2 x 18 mm (14G)	Nein

WEIGHT		LAUFRAD	GEWICHT
	29" VORDER-RAD	29" VORDER-RAD	1030 g +/- 5 %
	29" HINTERRAD	29" HINTERRAD	1180 g +/- 5 %
	27,5" HINTERRAD	27,5" HINTERRAD	1130 g +/- 5 %

**NUTZUNG**

**ASTM-Bedingung 5**  
(siehe Bedienungsanleitung)

Maximalgewicht des Systems (Rad+Fahrer+Ausrüstung) = **135 kg.**

MOUNTAIN CONTROL (MC)

MC32 TEAM POWER (ab MJ 2026)

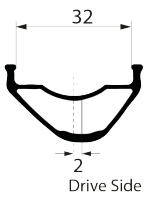
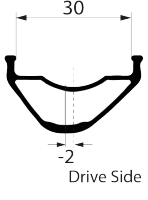
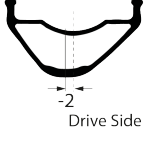
FELGEN	MODELL	MATERIAL	GRÖSSE	FELGENTYP	BREMSEN-TYP	TUBELESS	INNEN-MASS	VERSATZ	DIREKTIONALE SPEICHENLÖCHER	SPEICHENLÖCHER	ERD	ETRTO	VERBINDUNG	TUBELESS-BANDBREITE	VENTIL	KOMPATIBLE REIFEN	MAXIMAL-DRUCK	QUERSCHNITT	
	29" VORDERRAD-FELGE	MC36-F-29-28-LOCH	Aluminium AL6061	29"	Wulst Minihook	Scheibe	JA	32 mm	2 mm	JA	28	612,3 mm	622 x 32TSS	Hülle	32 mm	44 mm	2,4-2,8 Zoll	**	
	29" HINTERRAD-FELGE	MC36-R-29-32-Loch	Aluminium AL6061	29"	Wulst Minihook	Scheibe	JA	30 mm	-2 mm	JA	32	610,9 mm	622 x 30TSS	Hülle	30 mm	44 mm 57 mm beim Wild mit Ventilmagnet	2,05-2,8 Zoll	**	
	27,5" HINTERRAD-FELGE	MC37-R-27-32-Loch	Aluminium AL6061	27,5"	Wulst Minihook	Scheibe	JA	30 mm	-2 mm	JA	32	572,9 mm	584 x 30TSS	Hülle	30 mm	44 mm 57 mm beim Wild mit Ventilmagnet	2,05-2,8 Zoll	**	

SPEICHEN	Nein. SPEICHEN	MODELL	SPEICHENMUSTER ANTRIEBSSEITE	SPEICHENMUSTER NICHTANTRIEBSSEITE	SPEICHENLÄNGE ANTRIEBSSEITE	SPEICHENLÄNGE NICHTANTRIEBSSEITE	EINSPEICHSPANNUNG ANTRIEBSSEITE	EINSPEICHSPANNUNG SCHEIBENSEITE	DRUCKSPEICHE ANTRIEBSSEITE	ZUGSPEICHE ANTRIEBSSEITE	DRUCKSPEICHE NICHTANTRIEBSSEITE	ZUGSPEICHE NICHTANTRIEBSSEITE	
	29" VORDERRAD	28	Sapim E-Light. Konifiziert 14G (2 mm) J-Bend	3-fach Kreuzung	3-fach Kreuzung	301 mm	300 mm.	—	1300 N	Außen	Innen	Außen	Innen
	29" HINTERRAD	32	Sapim E-Light. Konifiziert 14G (2 mm) J-Bend	3-fach Kreuzung	3-fach Kreuzung	294 mm	295 mm	1300 N	—	Innen	Außen	Außen	Innen
	27,5" HINTERRAD	32	Sapim E-Light. Konifiziert 14G (2 mm) J-Bend	3-fach Kreuzung	3-fach Kreuzung	275 mm	276 mm	1300 N	—	Innen	Außen	Außen	Innen

HUB	MODELL	EINBAU-BREITE (OLD)	ACHSE	BREMS-SCHEIBENTYP	SPEICHEN	FREILAUF-KÖRPER	FREILAUFKÖRPER-MECHANISMUS	
	29" VORDER-RAD	DT SWISS 350 Hybrid Classic IS Modell ab MJ 2024	Boost 110 mm	Stek-kachse 15 mm	6-Loch	28 J-Bend	—	—
	29" HINTERRAD	DT SWISS 350 Hybrid Classic IS Modell ab MJ 2024	Boost 148 mm	Stek-kachse 12 mm	6-Loch	32 J-Bend	Sram XD oder Shimano MS	10 ° Ratchet 32
	27,5" HINTERRAD	DT SWISS 350 Hybrid Classic IS Modell ab MJ 2024	Boost 148 mm	Stek-kachse 12 mm	6-Loch	32 J-Bend	Sram XD oder Shimano MS	10 ° Ratchet 32

NIPPLES	MODELL	MASSE	SPEICHENNIPPEL-UNTERLEGSCHIEBEN	
	29" VORDER-RAD	Sapim Alloy Double Square	2 x 18 mm (14G)	Nein
	29" HINTERRAD	Sapim Alloy Double Square	2 x 18 mm (14G)	Nein
	27,5" HINTERRAD	Sapim Alloy Double Square	2 x 18 mm (14G)	Nein

WEIGHT	LAUFRAD	GE-WICHT
	29" VORDER-RAD	1030 g +/- 5 %
	29" HINTERRAD	1180 g +/- 5 %
	27,5" HINTERRAD	1130 g +/- 5 %

**NUTZUNG**

**ASTM-Bedingung 5**  
(siehe Bedienungsanleitung)

Maximalgewicht des Systems (Rad+Fahrer+Ausrüstung) = **135 kg.**

---

## WARTUNG VON OQUO-LAUFRÄDERN

Die in diesem Handbuch enthaltenen Informationen richten sich in erster Linie an das OQUO-Vertriebsnetz und Benutzer:innen, die über Erfahrung mit der Wartung von Laufrädern verfügen.

Wenn du als Benutzer:in nicht über die erforderlichen Kenntnisse verfügst, um die in diesem technischen Handbuch beschriebenen Wartungsarbeiten durchzuführen oder die aufgeführten Ersatzteile einzubauen, bringe deine Laufräder bitte zu einer OQUO-Verkaufsstelle. Sie wird die Reparatur bzw. Wartung für dich übernehmen.

Die Kontaktinformationen unseres Händlernetzes findest auf unserer Website:

[www.oquowheels.com](http://www.oquowheels.com)

### WARNUNG

Durch nicht fachgerechte Wartungs- oder Reparaturarbeiten verursachte Schäden fallen nicht unter die Gewährleistung.



Eine unsachgemäße Reparatur, Wartung oder Montage von Komponenten kann die Integrität und Funktion der Laufräder beeinträchtigen. Das kann zu Unfällen mit schweren Verletzungen oder Todesfolge führen.

### WERKZEUGE

Wichtig ist, dass immer die richtigen Werkzeuge und Produkte für die jeweilige Wartung oder Reparatur verwendet werden. Ungeeignete oder schlecht gepflegte Werkzeuge, aber auch die Verwendung von Allzweckprodukten, können Schäden an Komponenten verursachen, die dann nicht unter die Gewährleistung fallen.

In der Wartungsintervall-Tabelle in diesem Handbuch erfährst du, welche Überprüfungen an den Laufrädern und ihren Komponenten durchzuführen sind und welche Wartungsintervalle du einhalten solltest.

Im Abschnitt zur Nabenwartung in diesem Handbuch findest du die Wartungshandbücher der Nabenhersteller.

### WARTUNGSINTERVALL-TABELLE

Hinweise zu den Kontroll- und Wartungsintervallen für die Laufräder und ihre Komponenten findest du in der folgenden Tabelle.

### WARNUNG

Die im Folgenden für die Komponenten angegebenen Wartungsintervalle dienen der Einordnung und hängen stark von folgenden Faktoren ab: den Wetterbedingungen (widrige Wetterbedingungen können die Lebensdauer der Komponenten und die Wartungsintervalle wesentlich beeinflussen), der Pflege des Fahrrads und seiner Komponenten (Schmutzansammlungen sorgen für verstärkten Verschleiß der Komponenten), Einsatz des Fahrrads (wird das Fahrrad besonders stark beansprucht, verkürzen sich die Wartungsintervalle).

Schäden an Komponenten aufgrund nicht eingehaltener Wartungsfristen fallen nicht unter die Gewährleistung.

Die zu verwendenden Werkzeuge sind in diesem Handbuch angegeben. Bezüglich der an unseren Laufrädern verbauten Komponenten anderer Hersteller wird auch auf die entsprechenden Wartungshandbücher verwiesen, in denen die geeigneten Werkzeuge aufgeführt sind.

ÜBERPRÜFUNG	INTERVALL		
	Vor jeder Fahrt	Vor jeder 2. bis 3. Fahrt	Alle 4 - 6 Monate (40 - 60 Stunden) */**
Reinige die Laufräder mithilfe von Seifenwasser oder einem speziellen Reinigungsprodukt für Räder. (Verwende keine Produkte auf Ammoniakbasis oder Lösungsmittel)		✓	✓
Kontrolle des festen Sitzes und des Zustands der Steckachsen und der Schnellspanner	✓		
Kontrolle des Zustands der Bremsscheiben	✓		
Überprüfe den festen Sitz der Bremsscheiben			✓
Kontrolle der Felgenzentrierung	✓		✓
Kontrolle des Reifenzustands (Schnitte und Verschleiß)	✓		
Manuelle Kontrolle von Speichenspannung und Zustand	✓		
Manuelle Kontrolle von Drehung und Spiel der Naben und der Freilaufkörper	✓		
Kontrolle des Reifendrucks und eines eventuellen Druckverlusts	✓		
Überprüfung der Felgen, Naben und Speichen auf eventuelle Beschädigungen	✓		✓
Kontrolle und/oder Nachfüllen des Dichtmittels in Tubeless-Reifen			✓
Entfernen von Dichtmittelrückständen in Felge, Reifen und Ventil			✓
Gegebenenfalls Austauschen des Felgenbands (Standard oder Tubeless)			✓
Überprüfen der Speichenspannung mithilfe des Speichenspannungsmessers			✓
Gegebenenfalls Wartung von Nabenfunktion, Lager und Nabe gemäß der Hinweise des Herstellers			✓
Ersetzen des Schlauchs bei Standardreifen			✓

\* Abhängig vom Fahrstil und dem Gelände bzw. den Witterungsbedingungen sind diese Maßnahmen öfter erforderlich.

\*\*Bei schwereren Fahrer:innen oder bei einer Belastung der Laufräder im Bereich nahe des Maximalgewichts des Systems sind unter Umständen kürzere Wartungsintervalle erforderlich.

## WERKZEUGE FÜR LAUFRADWARTUNG UND -BAU

Hier sind die Werkzeuge aufgelistet, die für die fachgerechte Wartung von OQUO-Laufrädern sowohl beim Laufradbau als auch bei der Zentrierung benötigt werden. Die für die Nabenwartung erforderlichen Werkzeuge findest du in der Dokumentation des Herstellers.

Diese Aufstellung versteht sich vorbehaltlich technischer Änderungen an den Laufrädern, die die Verwendung anderer, hier nicht aufgeführter Werkzeuge erforderlich machen können. Im Zweifelsfall wende dich an OQUO.

### 1. ZENTRIERSTÄNDER ZUR BEIDSEITIGEN NUTZUNG

Verwende stets einen hochwertigen, beidseitig nutzbaren Zentrierständer, um die Zentrierung und den Rundlauf der Laufräder zu überprüfen. Grundsätzlich solltest du Laufräder zur Überprüfung und Wartung immer ausbauen. Nur so können präzise Ergebnisse gewährleistet werden.

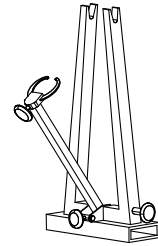

### 2. SPEICHENSCHLÜSSEL

**Außen:** Zum Verstellen der Speichennippel von der Felgenaußenseite. Für die meisten Speichennippel geeignet.

**Innen:** Zum Verstellen der Speichennippel von der Felgeninnenseite (vom Felgenbett). Sapim Double Square-Speichennippel können sowohl von der Felgeninnenseite als auch von der Außenseite mit einem passenden Speichenschlüssel gedreht werden.

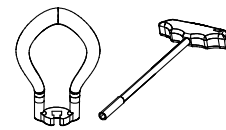

#### WARNUNG

Unabhängig davon, ob ein Speichenschlüssel für die Innen- oder Außenaufnahme verwendet wird, muss er die richtige Größe für die Nippel haben, um eine Beschädigung und/oder Abrundung der Nippel zu vermeiden. Es empfiehlt sich, verschieden große Speichenschlüssel zur Hand zu haben und diese an den einzustellenden Nippeln zu testen, um sicherzugehen, dass die richtige Größe verwendet wird.

### 3. FLACHSPEICHEN-SCHLÜSSEL

Verwende beim Anziehen des Speichennippels ein Gegenhaltewerkzeug für Flachspeichen, um ein Verdrehen der Speiche zu verhindern.

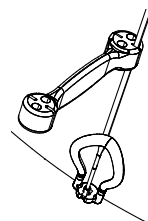

#### 4. SPANNUNGSMESSER

Verwende stets ein hochwertiges Spannungsmessgerät und überprüfe seine Kalibrierung regelmäßig gemäß den Anweisungen des Herstellers.

Befolge die Herstelleranweisungen für einen ordnungsgemäßen Gebrauch und eine korrekte Auswertung der Spannungswerte unter Berücksichtigung der Speichenspezifikation.

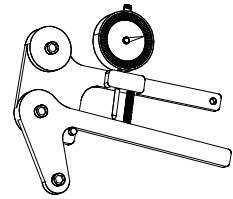

---

#### 5. SPURMESSGERÄT

Benutze stets eine Zentrierlehre, um die Mittigkeit der Felge in Bezug zu den Nabenenden zu überprüfen, die an der Rahmen- bzw. Gabelinnenseite montiert werden.

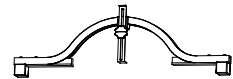

## PRÜFEN DER SPEICHENSPANNUNG

Überprüfe regelmäßig die Spannung und den Zustand der Speichen.

Überprüfe deine Laufräder regelmäßig auf einem Zentrierständer auf Seiten- (1) und Höhengschlag (2) sowie Mittigkeit (3). Wird das Laufrad für die Überprüfung und Einstellung nicht ausgebaut, kann möglicherweise nicht präzise gearbeitet werden.

Falls Speichen eingestellt werden müssen, reguliere die Speichenspannung mit einem Speichenschlüssel passender Größe.

Informationen zum Entspannen des Laufrads findest du im Abschnitt „Laufradbau“ in diesem Handbuch.

Überprüfe die Rundlauf- und Spannungsvorgaben für OQUO-Laufräder im Abschnitt „Laufradbau“ in diesem Handbuch.

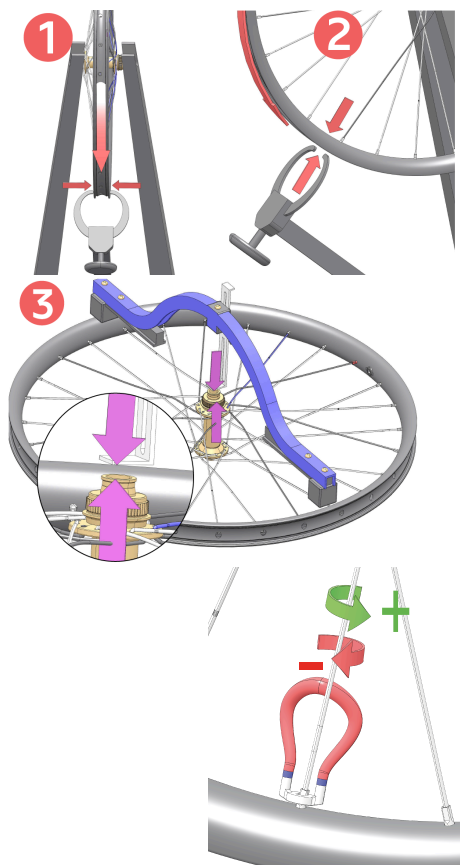

Verwende einen Flachspeichen-Schlüssel zum Gegenhalten bei Flachspeichen, um ein Verdrehen der Speiche zu verhindern. Runde Speichen können auch mit einer glatten Zange festgehalten werden, um ein Verdrehen zu verhindern. Die Speichen dürfen dabei nicht beschädigt werden.

Überprüfe das Laufrad beim Einstellen einer oder mehrerer Speichen erneut auf Seitenschlag, Höhengschlag und Mittigkeit. Wenn du vier oder mehr Speichen anziehst, entspanne das Laufrad und kontrolliere seine Zentrierung.

## ERSETZEN EINER SPEICHE

Gebrochene, verbogene oder beschädigte Speichen müssen umgehend ersetzt werden.

Um eine Speiche zu ersetzen, demontiere zunächst Reifen und Felgenband vom Laufrad.

Unter Umständen muss für den Speichenwechsel die Bremsscheibe – und bei Hinterrädern die Kassette – ausgebaut werden.



Verwende zum Entfernen des Speichennippels einen Speichenschlüssel (1, 2).

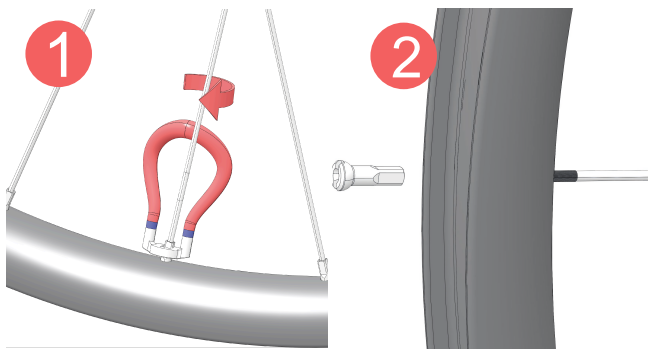

Löse die Speiche von der Nabe (3). Bei einem Speichenbruch kannst du die gebrochene Speiche zusammen mit dem Nippel ausbauen und das Speichenstück an der Nabe anschließend entfernen (4).

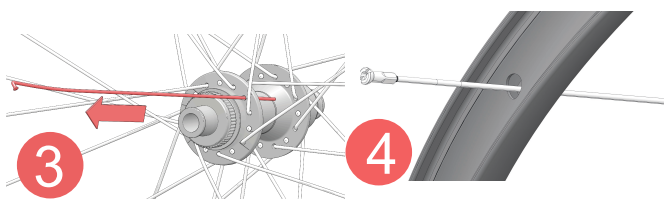

Baue die neue Speiche von der Nabenseite her und an der gleichen Stelle wie die Originalspeiche ein.

Informationen zur Anordnung der Speichen bei den verschiedenen Speichenmustern findest du im Abschnitt „Speichenmuster“ im Kapitel „Laufradbau“ in diesem Handbuch. In der Tabelle mit den technischen Daten in diesem Handbuch findest du Angaben zum Speichenmodell und zur Speichenlänge für deine OQUO-Laufräder.

Benutze einen Zentrierständer und geeignete Werkzeuge zum Spannen der neuen Speiche. Überprüfe nach dem Einbau, dass die Speichenspannung stimmt, und kontrolliere das Laufrad auf Seiten- und Höhengschlag sowie Mittigkeit.

Abgesehen von der ersetzten Speiche müssen gegebenenfalls auch andere Speichen nachgespannt werden. Werden mehrere Speichen eingebaut, musst du das Laufrad wie im Abschnitt „Laufradbau“ in diesem Handbuch beschrieben entspannen und kontrollieren, dass die Zentrierung, Spannung und Rundlauf toleranzen stimmen.

Montiere wieder das Felgenband, den Reifen, die Bremsscheibe und die Kassette, falls sie abgenommen werden mussten.

---

## NABENWARTUNG

### NABENWARTUNG

In der Tabelle mit den technischen Daten der OQUO-Laufräder in diesem Handbuch kannst du nachsehen, welches Nabenmodell zu deinem Laufradmodell passt.

Die Informationen in diesem Handbuch und in den Handbüchern anderer Hersteller, auf die hier verwiesen wird, richten sich in erster Linie an das Vertriebsnetz von OQUO und Komponentenherstellern sowie an Benutzer:innen, die über Erfahrung mit der Wartung von Laufrädern verfügen.

Wenn du als Benutzer:in nicht über die erforderlichen Kenntnisse verfügst, um die in diesem technischen Handbuch beschriebenen Wartungsarbeiten durchzuführen oder die aufgeführten Ersatzteile einzubauen, bringe deine Laufräder bitte zu einer OQUO-Verkaufsstelle. Sie wird die Reparatur bzw. Wartung für dich übernehmen.

Die Kontaktinformationen unseres Händlernetzes findest du auf unserer Website

[www.oquowheels.com](http://www.oquowheels.com)

#### WARNUNG

---

Durch nicht fachgerechte Wartungs- oder Reparaturarbeiten verursachte Schäden fallen nicht unter die Gewährleistung.



---

Eine unsachgemäße Reparatur, Wartung oder Montage von Komponenten kann die Integrität und Funktion der Laufräder beeinträchtigen. Das kann zu Unfällen mit schweren Verletzungen oder Todesfolge führen.

### DT SWISS MTB & OQUO DT INSIDE NABEN

Auf der folgenden Seite finden Sie Links zu den Handbüchern für die DT Swiss MTB-Naben auf der Website des Herstellers:

#### WARNUNG

---

Oquo DT Inside Naben bestehen aus den gleichen Komponenten wie die jeweils entsprechende Nabe von DT Swiss (mit Ausnahme des Nabenkörpers), daher gleichen die Service- und Wartungsverfahren denen des entsprechenden Nabenmodells von DT Swiss.

NABENMODELL	HANDBUCHTYP/ BEZEICHNUNG	INHALTE	LINK ZUM DOKUMENT
Alle Oquo DT Inside und DT Swiss Naben	Bedienungsanleitung/ NABEN BEDIENUNGSANLEITUNG ALLE NABEN	<ul style="list-style-type: none"> <li>Allgemeine Informationen</li> <li>Warnhinweise</li> <li>Montage</li> <li>Wartung und Pflege</li> </ul>	<a href="https://www.dtswiss.com/pmt/00/00/00/00/00/00/10/00/00/00/86/2/MAN_HXWXXXXXX1610S_WEB_ZZ_001.pdf">https://www.dtswiss.com/pmt/00/00/00/00/00/00/10/00/00/00/86/2/MAN_HXWXXXXXX1610S_WEB_ZZ_001.pdf</a>
Oquo DT Inside und DT Swiss Vorderradnaben	Technisches Handbuch/ TECHNISCHES HANDBUCH VORDERRADNABEN	<ul style="list-style-type: none"> <li>Demontage, Reinigung und Austausch der Lager und der Achse</li> <li>Benötigte Werkzeuge, Komponenten und Materialien</li> </ul>	<a href="https://d2a13k6araex7u.cloudfront.net/pmt/00/00/00/00/00/00/10/00/00/05/56/2/MAN_HXD10000005562S_WEB_EN_001.pdf">https://d2a13k6araex7u.cloudfront.net/pmt/00/00/00/00/00/00/10/00/00/05/56/2/MAN_HXD10000005562S_WEB_EN_001.pdf</a>
Oquo LTD DT Inside und DT Swiss 240 Hinterradnabe	Technisches Handbuch/ TECHNISCHES HANDBUCH RATCHET EXP NABEN	<ul style="list-style-type: none"> <li>Demontage, Reinigung und Austausch aller Nabenkomponenten</li> <li>Benötigte Werkzeuge, Komponenten und Materialien</li> </ul>	<a href="https://www.dtswiss.com/pmt/00/00/00/00/00/00/10/00/00/03/11/1/MAN_HXD10000003111S_WEB_EN_001.pdf">https://www.dtswiss.com/pmt/00/00/00/00/00/00/10/00/00/03/11/1/MAN_HXD10000003111S_WEB_EN_001.pdf</a>
	Gehäuse-Wartungshandbuch WARTUNG DES RATCHET EXP FREILAUFSATZES	<ul style="list-style-type: none"> <li>Demontage, Reinigung und Austausch des Ratchet EXP-Systems und des Gehäuse</li> <li>Benötigte Werkzeuge, Komponenten und Materialien</li> </ul>	<a href="https://www.dtswiss.com/pmt/00/00/00/00/00/00/10/00/00/04/19/3/MAN_HXD10000004193S_XXX_EN_001.pdf">https://www.dtswiss.com/pmt/00/00/00/00/00/00/10/00/00/04/19/3/MAN_HXD10000004193S_XXX_EN_001.pdf</a>
	Handbuch für Austausch von Ratchet EXP 36Z durch EXP 54Z UMBAU VON RATCHET EXP NABE 36 AUF 54	<ul style="list-style-type: none"> <li>Ersetzen des Ratchet EXP 36Z-Systems durch EXP 54Z</li> <li>Benötigte Werkzeuge, Komponenten und Materialien</li> </ul>	<a href="https://www.dtswiss.com/pmt/00/00/00/00/00/00/10/00/00/03/77/3/MAN_HXD10000003773S_WEB_EN_001.pdf">https://www.dtswiss.com/pmt/00/00/00/00/00/00/10/00/00/03/77/3/MAN_HXD10000003773S_WEB_EN_001.pdf</a>
Oquo LTD DT Inside und DT Swiss 350 DEG 72 Hinterradnabe	Alles über die 350 DEG Nabe/ DT Swiss Support-Seite	<ul style="list-style-type: none"> <li>Ersatzteile</li> <li>Handbücher</li> <li>Videos</li> </ul>	<a href="https://www.dtswiss.com/en/support/product-support?matnr=H350TDDRR32SA5051S">https://www.dtswiss.com/en/support/product-support?matnr=H350TDDRR32SA5051S</a>
	Technisches Handbuch/ RATCHET DEG NABEN	<ul style="list-style-type: none"> <li>Demontage, Reinigung und Austausch aller Nabenkomponenten</li> <li>Benötigte Werkzeuge, Komponenten und Materialien</li> </ul>	<a href="https://d2a13k6araex7u.cloudfront.net/pmt/00/00/00/00/00/00/10/00/00/05/10/4/MAN_HXD10000005104S_WEB_EN_001.pdf">https://d2a13k6araex7u.cloudfront.net/pmt/00/00/00/00/00/00/10/00/00/05/10/4/MAN_HXD10000005104S_WEB_EN_001.pdf</a>
	Video/ 350 DEG KOMPLETTSERVICE	<ul style="list-style-type: none"> <li>Demontage, Reinigung und Austausch aller Nabenkomponenten</li> <li>Benötigte Werkzeuge, Komponenten und Materialien</li> </ul>	<a href="https://www.youtube.com/watch?v=UMLquGPw2Jg">https://www.youtube.com/watch?v=UMLquGPw2Jg</a>
Oquo Team DT Inside und DT Swiss 350 Hinterradnabe	Technisches Handbuch/ TECHNISCHES HANDBUCH RATCHET NABEN	<ul style="list-style-type: none"> <li>Demontage, Reinigung und Austausch aller Nabenkomponenten</li> <li>Benötigte Werkzeuge, Komponenten und Materialien</li> </ul>	<a href="https://www.dtswiss.com/pmt/00/00/00/00/00/00/10/00/00/00/89/6/MAN_WXD10000000896S_WEB_EN_001.pdf">https://www.dtswiss.com/pmt/00/00/00/00/00/00/10/00/00/00/89/6/MAN_WXD10000000896S_WEB_EN_001.pdf</a>
DT SWISS 350 Hybrid	Technisches Handbuch/ TECHNISCHES HANDBUCH RATCHET NABEN	<ul style="list-style-type: none"> <li>Demontage, Reinigung und Austausch aller Nabenkomponenten</li> <li>Benötigte Werkzeuge, Komponenten und Materialien</li> </ul>	<a href="https://www.dtswiss.com/pmt/00/00/00/00/00/00/10/00/00/00/89/6/MAN_WXD10000000896S_WEB_EN_001.pdf">https://www.dtswiss.com/pmt/00/00/00/00/00/00/10/00/00/00/89/6/MAN_WXD10000000896S_WEB_EN_001.pdf</a>
DT Swiss 370 Hinterradnabe	TECHNISCHES HANDBUCH RATCHET LN NABEN	<ul style="list-style-type: none"> <li>Demontage, Reinigung und Austausch aller Nabenkomponenten</li> <li>Benötigte Werkzeuge, Komponenten und Materialien</li> </ul>	<a href="https://www.dtswiss.com/pmt/00/00/00/00/00/00/10/00/00/03/77/4/MAN_HXD10000003774S_WEB_EN_001.pdf">https://www.dtswiss.com/pmt/00/00/00/00/00/00/10/00/00/03/77/4/MAN_HXD10000003774S_WEB_EN_001.pdf</a>

## ERSATZTEILE

### OQUO DT SWISS INSIDE NABENERSATZTEILE

In der Tabelle mit den technischen Daten der OQUO-Laufräder findest du Angaben zum Nabenmodell in deinen Laufrädern

#### OQUO DT SWISS INSIDE VORDERRADNABEN

##### Oquo LTD DT Swiss 240 Inside Straight Pull 15x110 24-Loch Centerlock

In der Tabelle mit den technischen Daten der OQUO-Laufräder findest du Angaben zum Nabenmodell in deinen Laufrädern

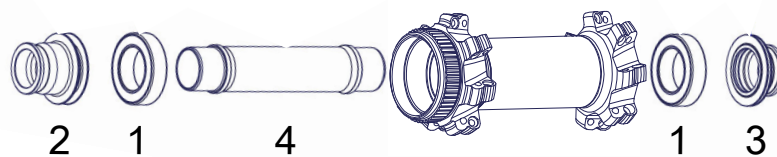

	BESCHREIBUNG	ANZAHL PRO NABE	ART. NR. DT DT SWISS	ART. NR. ORBEA
1	Kugellager - B.BEARING 1728 ESB/ESNB L	2	HSBXXX00N9115S	<a href="#">XB68</a>
2	VR Endanschlag links - FW ADAPT WP XXX/ 15 L BM DISC	1	HWAXXX00S2760S	<a href="#">XB69</a>
3	VR Endanschlag rechts - FW ADAPT WP XXX/15 R BM DISC	1	HWAXXX00S2761S	<a href="#">XB70</a>
4	VR Achse - FW AXLE AL 110 mm Ø17/64,3 mm	1	HRCXXX00N3296S	<a href="#">XB71</a>

	BESCHREIBUNG	ART. NR. DT DT SWISS	ART. NR. ORBEA
<b>Montagefett</b>	DT Swiss Universalfett 20 g	HXTXXX00NMG20S	<a href="#">XB72</a>
<b>Werkzeuge</b>	Montagehülse Ø17 / 28 mm x 40 mm	HXTXXX00N9345S	<a href="#">XB73</a>
	Achsenwerkzeug Ø17 mm	HXTXXX00N5067S	<a href="#">XB74</a>

Für Online-Bestellung die Teilenummer anklicken. Naben-Ersatzteile sind ausschließlich für Orbea-Händler über Kide (B2B-Zugang) erhältlich.

## OQUO DT SWISS INSIDE VORDERRADNABEN

## Oquo TEAM DT Swiss 350 Inside Straight Pull 15x110 28-Loch Centerlock/6-Loch

In der Tabelle mit den technischen Daten der OQUO-Laufräder findest du Angaben zum Nabenmodell in deinen Laufrädern

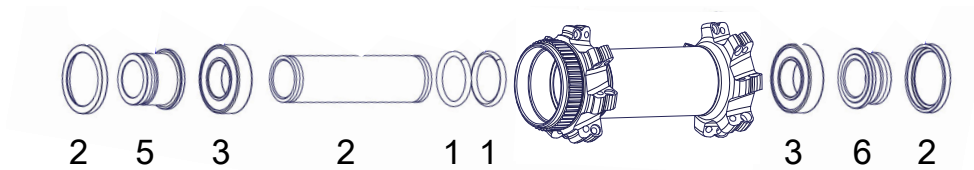

	BESCHREIBUNG	ANZAHL PRO NABE	ART. NR. DT SWISS	ART. NR. ORBEA
1	O-Ring - O-RING Ø18 X 2,5 mm NBR 70 SHORE ISO3601	2	HSOXXX00X2164S	XC04
2	VR Abdeckung - FW COVER FOR TA15 mm	2	HCD00100S4603S	XC05
3	Kugellager - B.BEARING 6902 ESB/ESNB L	2	HSBXXX00N2336S	XC06
4	SPACER Ø15 mm x 67,2 mm	1	HXD00000N6567C	XC07
5	VR Endanschlag links - FW ADAPT SP XXX/ 15 L B	1	HCA00100S7745S	XC08
6	VR Endanschlag rechts - FW ADAPT SP XXX/15 R B	1	HCA00100S7744S	XC09

	BESCHREIBUNG	ART. NR. DT SWISS	ART. NR. ORBEA
<b>Montagefett</b>	DT Swiss Universalfett 20 g	HXTXXX00NMG20S	XB72
<b>Werkzeuge</b>	Werkzeugsatz 350 15 mm	HWTXXX00N5290S	XC10
	Montagewerkzeug	HXTXXX00N9793S	XC11

Für Online-Bestellung die Teilenummer anklicken. Naben-Ersatzteile sind ausschließlich für Orbea-Händler über Kide (B2B-Zugang) erhältlich.

## OQUO DT SWISS INSIDE VORDERRADNABEN

## Oquo LTD DT Swiss 350 Inside J-bend 15x110 28-Loch 6-Loch

In der Tabelle mit den technischen Daten der OQUO-Laufräder findest du Angaben zum Nabenmodell in deinen Laufrädern

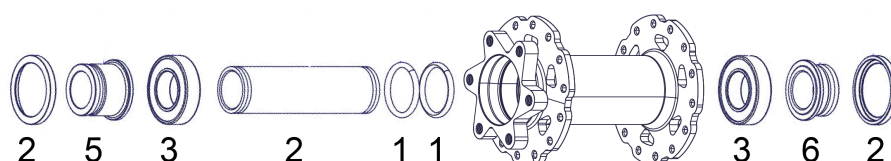

	BESCHREIBUNG	ANZAHL PRO NABE	ART. NR. DT SWISS	ART. NR. ORBEA
1	O-Ring - O-RING Ø18 X 2,5 mm NBR 70 SHORE ISO3601	2	HSOXXX00X2164S	XC04
2	VR Abdeckung - FW COVER FOR TA15 mm	2	HCD00100S4603S	XC05
3	Kugellager - B.BEARING 6902 ESB/ESNB L	2	HSBXXX00N2336S	XC06
4	SPACER Ø15 mm x 67,2 mm	1	HXD00000N6567C	XC07
5	VR Endanschlag links - FW ADAPT SP XXX/15 L B	1	HCA00100S7745S	XC08
6	VR Endanschlag rechts - FW ADAPT SP XXX/15 R B	1	HCA00100S7744S	XC09

	BESCHREIBUNG	ART. NR. DT SWISS	ART. NR. ORBEA
<b>Montagefett</b>	DT Swiss Universalfett 20 g	HXTXXX00NMG20S	XB72
<b>Werkzeuge</b>	Werkzeugsatz 350 15 mm	HWTXXX00N5290S	XC10
	Montagewerkzeug	HXTXXX00N9793S	XC11

Für Online-Bestellung die Teilenummer anklicken. Naben-Ersatzteile sind ausschließlich für Orbea-Händler über Kide (B2B-Zugang) erhältlich.

## OQUO DT SWISS INSIDE HINTERRADNABEN

### Oquo LTD DT Swiss 240 Inside Straight Pull 12x148 28-Loch Centerlock

In der Tabelle mit den technischen Daten der OQUO-Laufräder findest du Angaben zum Nabenmodell in deinen Laufrädern

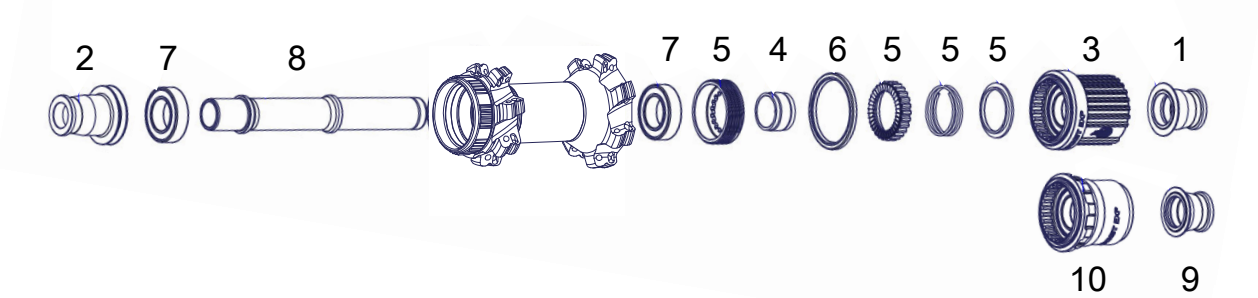

	BESCHREIBUNG	ANZAHL PRO NABE	ART. NR. DT SWISS	ART. NR. ORBEA
1	HR Endanschlag rechts - RW ADAPT WP XXX/12 R BM MS	1	HWAXXX00S2766S	<a href="#">XB87</a>
2	HR Endanschlag links - RW ADAPT WP XXX/12 L BM	1	HWAXXX00S2763S	<a href="#">XB88</a>
3	Freilaufkörper - FB W MTB SHI MS EXP AL LI SL M	1	HWRABL00S4863S	<a href="#">XB89</a>
4	Distanzhülse - SPACER ALLOY 10.7 EXP	1	HRDXXX00N8242S	<a href="#">XB90</a>
5	Wartungskit - SERVICE KIT RATCHET 36T EXP W/O TOOL	1	HWYXXX00N0042S	<a href="#">XB91</a>
6	Dichtung Nabe/Rotor - SEAL HUB/ROTOR (Ø30 x 36 x 2,5 mm)	1	HSOXXX00N1031S	<a href="#">XB92</a>
7	Kugellager - B.BEARING 1526 ESB/ESNB L	2	HSBXXX00N3741S	<a href="#">XB93</a>
8	HR Achse - RW AXLE AL XXX mm Ø15/52,85 mm EXP	1	HCCXXX00S3303S	<a href="#">XB94</a>
9	HR Endanschlag rechts - RW ADAPT WP XXX/12 R BM SRAM XD	1	HWAXXX00S2767S	<a href="#">XB95</a>
10	Freilaufkörper - FB W MTB SRA XD EXP AL ST SL M	1	HWRABL00S3830S	<a href="#">XB96</a>

	BESCHREIBUNG	ART. NR. DT SWISS	ART. NR. ORBEA
<b>Montagefett</b>	DT Swiss Universalfett 20 g	HXTXXX00NMG20S	<a href="#">XB72</a>
	DT Swiss Spezialfett 20 g	HXT10032508S	<a href="#">XB97</a>
<b>Werkzeuge</b>	Montagehülse 15 x 26 x 40 mm	HWTXXX00N5290S	<a href="#">XB98</a>
	Montage-/Demontagewerkzeug für Zahnscheibe mit Gewinde	HXTXXX00N9793S	<a href="#">XB99</a>
	Montage-/Demontagewerkzeug Kugellager Antriebsseite	HWTXXX00N5290S	<a href="#">XC01</a>
	Montagewerkzeug für Nabendichtung	HXTXXX00N9793S	<a href="#">XC02</a>

Für Online-Bestellung die Teilenummer anklicken. Naben-Ersatzteile sind ausschließlich für Orbea-Händler über Kide (B2B-Zugang) erhältlich.

## OQUO DT SWISS INSIDE HINTERRADNABEN

### Oquo LTD DT Swiss 350 Inside Straight Pull 12x148 28/32H Centerlock/6-Loch

In der Tabelle mit den technischen Daten der OQUO-Laufräder findest du Angaben zum Nabenmodell in deinen Laufrädern

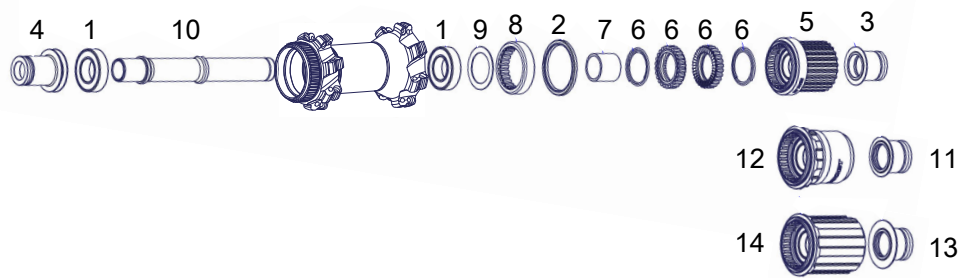

	BESCHREIBUNG	ANZAHL PRO NABE	ART. NR. DT SWISS	ART. NR. ORBEA
1	B.BEARING 6902 ESB/ESNB L	2	HSBXXX00N2336S	XC06
2	SEAL HUB/ROTOR (diam 30x36x2.5mm)	1	HSOXXX00N1031S	XB92
3	RW ADAPT WP XXX/12 R B MS	1	HWA00100S7912S	XC15
4	RW ADAPT WP XXX/12 L B	1	HWA00100S7841S	XC17
5	FB W MTB SHI MS RAT AL LI SL B	1	HWRABL00S2148S	XC19
6	SERVICE KIT RATCHET 36T	1	HWTXXX00NSK36S	XC20
7	SPACER ALLOY 15.4 mm BL	1	HCDXXX00S1077S	XC21
8	RING NUT STEEL M34X1 240	1	HXDXXX00N1131S	XC22
9	SHIM RING diam 28/20X0.5mm	1	HCDXXX00S1083S	XC23
10	RW AXLE AL 148mm diam 15/48.2mm	1	HCCXXX00S6450S	XC24
11	RW ADAPT WP XXX/12 R B SRAM XD	1	HWA00100S7513S	XC25
12	FB W MTB SRA XD RAT AL ST SL B	1	HWRAAL00S3114S	XC26
13	RW ADAPT WP XXX/12 R B	1	HWA00100S7892S	XC27
14	FB W MTB SHI RAT AL LI	1	HWRABL00S1239S	XC28

	BESCHREIBUNG	ART. NR. DT SWISS	ART. NR. ORBEA
<b>Montagefett</b>	DT Swiss universal grease 20 g	HXTXXX00NMG20S	XB72
	DT Swiss special grease 20 g	HXT10032508S	XB97
<b>Werkzeuge</b>	Installation cylinder 15x26x40 mm	HWTXXX00N5290S	XB98
	Installation tool for hub seal	HXTXXX00N1000S	XC02
	Tool for ring nut	HXTXXX00N5027S	XC32

Für Online-Bestellung die Teilenummer anklicken. Naben-Ersatzteile sind ausschließlich für Orbea-Händler über Kide (B2B-Zugang) erhältlich.

## OQUO DT SWISS INSIDE HINTERRADNABEN

### Oquo LTD DT Swiss Inside 350 DEG J-bend 12x148 32H 6-Loch

In der Tabelle mit den technischen Daten der OQUO-Laufräder findest du Angaben zum Nabenmodell in deinen Laufrädern

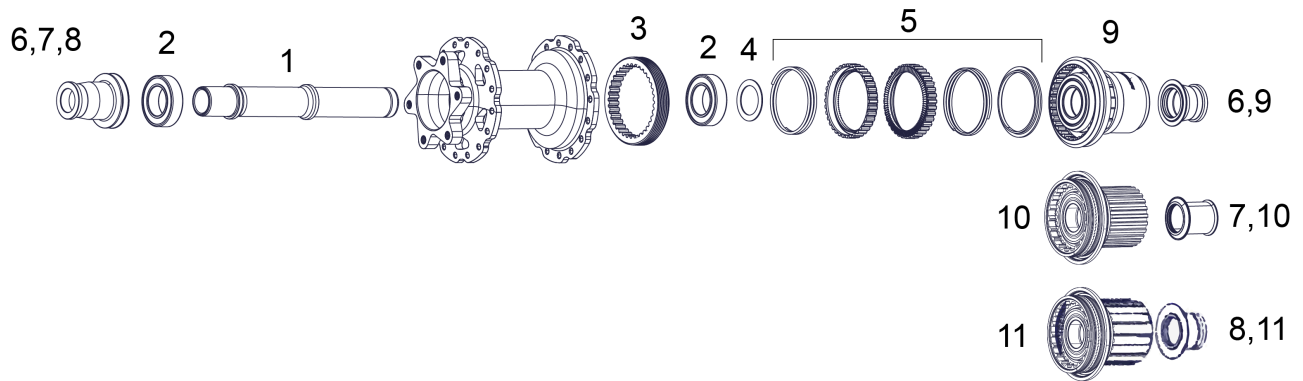

	BESCHREIBUNG	ANZAHL PRO NABE	ART. NR. DT SWISS	ART. NR. ORBEA
1	Hinterradachse - RW AXLE AL 148 mm Ø15/48,2 mm	1	HCCXXX00S6450S	<a href="#">XC24</a>
2	Kugellager - B.BEARING 6902 ESB/ESNB L	2	HSBXXX00N2336S	<a href="#">XC06</a>
3	GEWINDERING ST M45X2-2MM DEG	1	HXDXXX00N9037S	<a href="#">XJ88</a>
4	SPACER ALUMINIUM 2,95 mm N	1	HCD14200N9313S	<a href="#">XJ89</a>
5	SERVICE-KIT RATCHET 72T DEG	1	HWYXXX00N6599S	<a href="#">XJ90</a>
6	HR-UMRÜST-KIT 142/Ø12 240 SRAM XD (NUR ENDKAPPEN)	1	HWGXXX00S3188S	<a href="#">X649</a>
7	HR-UMRÜST-KIT XXX/12 B MS (NUR ENDKAPPEN)	1	HWGXXX00S5643S	<a href="#">X647</a>
8	UMRÜST-KIT X12 HG (NUR ENDKAPPEN)	1	HWGXXX0002193C	<a href="#">X648</a>
9	FB K MTB SRA XD DEG 12/148 AL ST SL B	1	HWYABL00S2779S	<a href="#">XJ91</a>
10	FB K MTB SHI MS DEG 12/148 AL ST SL B	1	HWYABL00S2787S	<a href="#">XJ92</a>
11	FB K MTB SHI DEG 12/148 AL ST SL B	1	HWYABL00S2786S	<a href="#">XJ93</a>

	BESCHREIBUNG	ART. NR. DT SWISS	ART. NR. ORBEA
<b>Montagefett</b>	DT Swiss Universalfett 20 g	HXTXXX00NMG20S	<a href="#">XB72</a>
	DT Swiss Spezialfett 20 g	HXT10032508S	<a href="#">XB97</a>
<b>Werkzeuge</b>	Montagehülse 15 x 26 x 40 mm	HWYXXX00N5290S	<a href="#">XB98</a>
	Montagehülse Ø15 / 28 x 35 mm	HXTXXX00N5024S	<a href="#">XC02</a>
	Werkzeug für Gewinding DEG	HXTXXX00N2612S	<a href="#">XJ94</a>

Für Online-Bestellung die Teilenummer anklicken. Naben-Ersatzteile sind ausschließlich für Orbea-Händler über Kide (B2B-Zugang) erhältlich.

**OQUO DT SWISS INSIDE HINTERRADNABEN****ERSATZTEILE FÜR DT SWISS-NABEN**

In der Tabelle mit den technischen Daten der OQUO-Laufräder findest du Angaben zum Nabenmodell in deinen Laufrädern

**DT SWISS VORDERRADNABEN****DT Swiss 240 J-bend 15x110 24/28-Loch Centerlock/6-Loch**

In der Tabelle mit den technischen Daten der OQUO-Laufräder findest du Angaben zum Nabenmodell in deinen Laufrädern

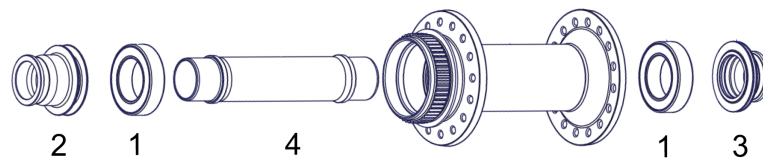

	BESCHREIBUNG	ANZAHL PRO NABE	ART. NR. DT DT SWISS	ART. NR. ORBEA
1	Kugellager - B.BEARING 1728 ESB/ESNB L	2	HSBXXX00N9115S	<a href="#">XB68</a>
2	VR Endanschlag links - FW ADAPT WP XXX/15 L BM DISC	1	HWAXXX00S2760S	<a href="#">XB69</a>
3	VR Endanschlag rechts - FW ADAPT WP XXX/15 R BM DISC	1	HWAXXX00S2761S	<a href="#">XB70</a>
4	VR Achse - FW AXLE AL 110 mm Ø17/64,3 mm	1	HRCXXX00N3296S	<a href="#">XB71</a>

	BESCHREIBUNG	ART. NR. DT SWISS	ART. NR. ORBEA
<b>Montagefett</b>	DT Swiss Universalfett 20 g	HXTXXX00NMG20S	<a href="#">XB72</a>
<b>Werkzeuge</b>	Montagehülse Ø17 / 28 mm x 40 mm	HXTXXX00N9345S	<a href="#">XB73</a>
	Achsenwerkzeug Ø17 mm	HXTXXX00N5067S	<a href="#">XB74</a>

Für Online-Bestellung die Teilenummer anklicken. Naben-Ersatzteile sind ausschließlich für Orbea-Händler über Kide (B2B-Zugang) erhältlich.

## DT SWISS VORDERRADNABEN

## DT Swiss 350 J-bend 15x110 28-Loch Centerlock/6-Loch

In der Tabelle mit den technischen Daten der OQUO-Laufräder findest du Angaben zum Nabenmodell in deinen Laufrädern

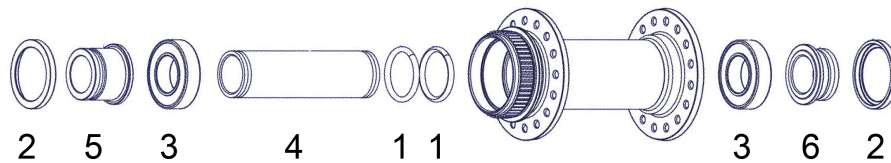

	BESCHREIBUNG	ANZAHL PRO NABE	ART. NR. DT SWISS	ART. NR. ORBEA
1	O-Ring - O-RING Ø18 X 2,5 mm NBR 70 SHORE ISO3601	2	HSOXXX00X2164S	XC04
2	VR Abdeckung - FW COVER FOR TA15 mm	2	HCD00100S4603S	XC05
3	Kugellager - B.BEARING 6902 ESB/ESNB L	2	HSBXXX00N2336S	XC06
4	SPACER Ø15 mm x 67,2 mm	1	HXD00000N6567C	XC07
5	VR Endanschlag links - FW ADAPT SP XXX/15 L B	1	HCA00100S7745S	XC08
6	VR Endanschlag rechts - FW ADAPT SP XXX/15 R B	1	HCA00100S7744S	XC09

	BESCHREIBUNG	ART. NR. DT SWISS	ART. NR. ORBEA
<b>Montagefett</b>	DT Swiss Universalfett 20 g	HXTXXX00NMG20S	XB72
<b>Werkzeuge</b>	Werkzeugsatz 350 15 mm	HWTXXX00N5290S	XC10
	Montagewerkzeug	HXTXXX00N9793S	XC11

Für Online-Bestellung die Teilenummer anklicken. Naben-Ersatzteile sind ausschließlich für Orbea-Händler über Kide (B2B-Zugang) erhältlich.

## DT SWISS VORDERRADNABEN

## DT Swiss 350 J-bend 20x110 28-Loch 6-Loch

In der Tabelle mit den technischen Daten der OQUO-Laufräder findest du Angaben zum Nabenmodell in deinen Laufrädern

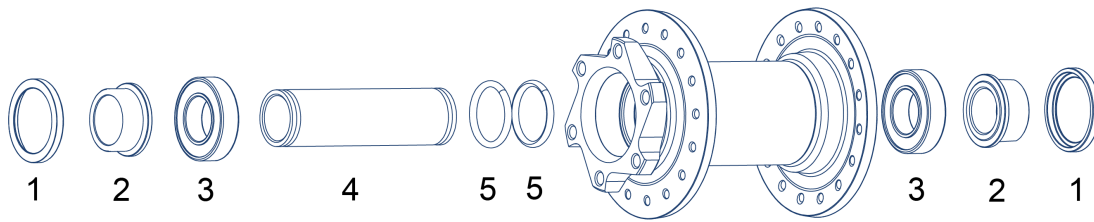

	BESCHREIBUNG	ANZAHL PRO NABE	ART. NR. DT SWISS	ART. NR. ORBEA
1	FW COVER FOR TA20mm	2	HCDXXX00S1461S	XJ95
2	FW ADAPT SP 110X DBIS TA20 B	2	HCAXXX00S6824S	XJ96
3	Kugellager - B.BEARING 6904 ESB/ESNB L	2	HSBXXX00N1414S	XJ97
4	FW SPACER 65,1x25 MM	1	HXDXXX00N6823S	XJ98
5	O-Ring - O-RING Ø18 X 2,5 mm NBR 70 SHORE ISO3601	2	HSOXXX00X2164S	XC04

	BESCHREIBUNG	ART. NR. DT SWISS	ART. NR. ORBEA
<b>Montagefett</b>	DT Swiss Universalfett 20 g	HXTXXX00NMG20S	XB72
<b>Werkzeuge</b>	Werkzeugsatz 350 20 mm	HWTXXX00N5292S	—
	Montagewerkzeug	HXTXXX00N9793S	XC11

Für Online-Bestellung die Teilenummer anklicken. Naben-Ersatzteile sind ausschließlich für Orbea-Händler über Kide (B2B-Zugang) erhältlich.

## DT SWISS VORDERRADNABEN

## DT Swiss 370 J-bend 15x110 28-Loch 6-Loch

In der Tabelle mit den technischen Daten der OQUO-Laufräder findest du Angaben zum Nabenmodell in deinen Laufrädern

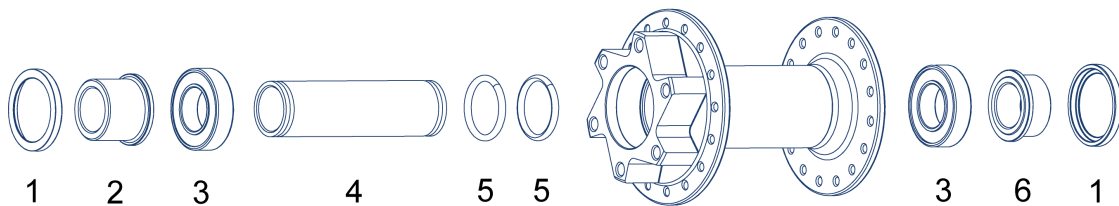

	BESCHREIBUNG	ANZAHL PRO NABE	ART. NR. DT SWISS	ART. NR. ORBEA
1	VR Abdeckung - FW COVER FOR TA15 mm	2	HCD00100S4603S	<a href="#">XC05</a>
2	VR Endanschlag links - FW ADAPT SP 100L DBCL SA15 S	1	HCA00100S4601S	<a href="#">XC48</a>
3	Kugellager - B.BEARING 6902 ESB/ESNB L	2	HSBXXX00N2336S	<a href="#">XC06</a>
4	Distanzhülse - SPACER Ø15 mm x 67,2 mm	1	HXD00000N6567C	<a href="#">XC07</a>
5	O-Ring - O-RING Ø18 X 2,5 mm NBR 70 SHORE ISO3601	2	HSOXXX00X2164S	<a href="#">XC04</a>
6	VR Endanschlag rechts - FW ADAPT SP 100R DBCL SA15 S	1	HCA00100S4602S	<a href="#">XC47</a>

	BESCHREIBUNG	ART. NR. DT SWISS	ART. NR. ORBEA
<b>Montagefett</b>	DT Swiss Universalfett 20 g	HXTXXX00NMG20S	<a href="#">XB72</a>
<b>Werkzeuge</b>	Werkzeugsatz 350 15 mm	HWTXXX00N5290S	<a href="#">XC10</a>
	Montagewerkzeug	HXTXXX00N9793S	<a href="#">XC11</a>

Für Online-Bestellung die Teilenummer anklicken. Naben-Ersatzteile sind ausschließlich für Orbea-Händler über Kide (B2B-Zugang) erhältlich.

## DT SWISS VORDERRADNABEN

## DT Swiss 350 Hybrid J-bend 15x110 32-Loch 6-Loch (bis MJ 2023)

In der Tabelle mit den technischen Daten der OQUO-Laufräder findest du Angaben zum Nabenmodell in deinen Laufrädern

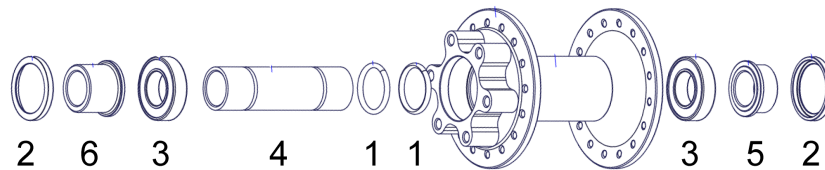

	BESCHREIBUNG	ANZAHL PRO NABE	ART. NR. DT SWISS	ART. NR. ORBEA
1	O-Ring - O-RING Ø18 X 2,5 mm NBR 70 SHORE ISO3601	2	HSOXXX00X2164S	<a href="#">XC04</a>
2	VR Abdeckung - FW COVER FOR TA15 mm	2	HCD00100S4603S	<a href="#">XC05</a>
3	Kugellager - B.BEARING 6902 ESB/ESNB L	2	HSBXXX00N2336S	<a href="#">XC06</a>
4	SPACER Ø15 mm x 67,2 mm	1	HXD00000N6449S	<a href="#">XC46</a>
5	VR Endanschlag rechts - FW ADAPT SP 100R DBCL SA15 S	1	HCA00100S4602S	<a href="#">XC47</a>
6	VR Endanschlag links - FW ADAPT SP 100L DBCL SA15 S	1	HCA00100S4601S	<a href="#">XC48</a>

	BESCHREIBUNG	ART. NR. DT SWISS	ART. NR. ORBEA
<b>Montagefett</b>	DT Swiss Universalfett 20 g	HXTXXX00NMG20S	<a href="#">XB72</a>
<b>Werkzeuge</b>	Werkzeugsatz 350 15 mm	HWTXXX00N5290S	<a href="#">XC10</a>
	Montagewerkzeug	HXTXXX00N9793S	<a href="#">XC11</a>

Für Online-Bestellung die Teilenummer anklicken. Naben-Ersatzteile sind ausschließlich für Orbea-Händler über Kide (B2B-Zugang) erhältlich.

## DT SWISS VORDERRADNABEN

## DT Swiss 350 Hybrid J-bend 15x110 28-Loch 6-Loch (aus MJ 2024)

In der Tabelle mit den technischen Daten der OQUO-Laufräder findest du Angaben zum Nabenmodell in deinen Laufrädern

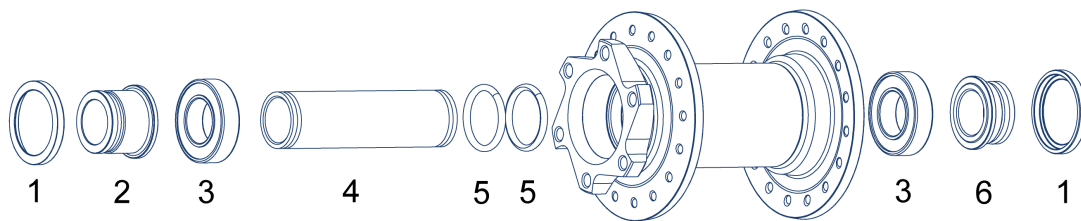

	BESCHREIBUNG	ANZAHL PRO NABE	ART. NR. DT SWISS	ART. NR. ORBEA
1	VR Abdeckung - FW COVER FOR TA15 mm	2	HCD00100S4603S	XC05
2	VR Endanschlag links - FW ADAPT SP XXX/ 15 L B	1	HCA00100S7745S	XC08
3	Kugellager - B.BEARING 6902 ESB/ESNB L	2	HSBXXX00N2336S	XC06
4	Distanzhülse - SPACER Ø15 mm x 67,2 mm	1	HXD00000N6567C	XC07
5	O-Ring - O-RING Ø18 X 2,5 mm NBR 70 SHORE ISO3601	2	HSOXXX00X2164S	XC04
6	VR Endanschlag rechts - FW ADAPT SP XXX/ 15 R B	1	HCA00100S7744S	XC09

	BESCHREIBUNG	ART. NR. DT SWISS	ART. NR. ORBEA
<b>Montagefett</b>	DT Swiss Universalfett 20 g	HXTXXX00NMG20S	XB72
<b>Werkzeuge</b>	Werkzeugsatz 350 15 mm	HWTXXX00N5290S	XC10
	Montagewerkzeug	HXTXXX00N9793S	XC11

Für Online-Bestellung die Teilenummer anklicken. Naben-Ersatzteile sind ausschließlich für Orbea-Händler über Kide (B2B-Zugang) erhältlich.

## DT SWISS HINTERRADNABEN

## DT Swiss 240 J-bend 12x148 28-Loch Centerlock

In der Tabelle mit den technischen Daten der OQUO-Laufräder findest du Angaben zum Nabenmodell in deinen Laufrädern

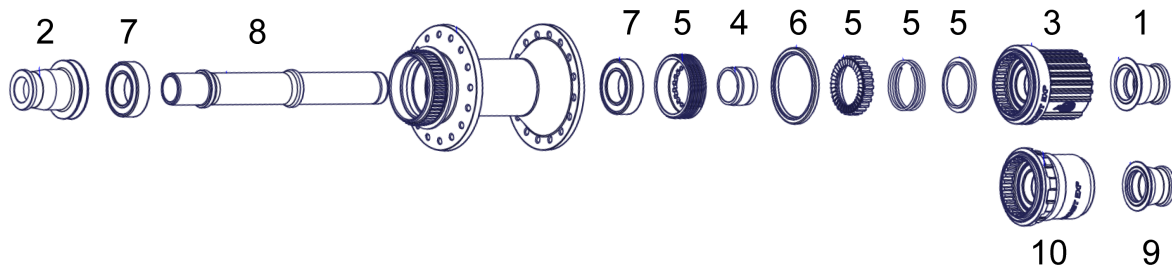

	BESCHREIBUNG	ANZAHL PRO NABE	ART. NR. DT SWISS	ART. NR. ORBEA
1	HR Endanschlag rechts - RW ADAPT WP XXX/12 R BM MS	1	HWAXXX00S2766S	<a href="#">XB87</a>
2	HR Endanschlag links - RW ADAPT WP XXX/12 L BM	1	HWAXXX00S2763S	<a href="#">XB88</a>
3	Freilaufkörper - FB W MTB SHI MS EXP AL LI SL M	1	HWRABL00S4863S	<a href="#">XB89</a>
4	Distanzhülse - SPACER ALLOY 10.7 EXP	1	HRDXXX00N8242S	<a href="#">XB90</a>
5	Wartungskit - SERVICE KIT RATCHET 36T EXP W/O TOOL	1	HWYXXX00N0042S	<a href="#">XB91</a>
6	Dichtung Nabe/Rotor - SEAL HUB/ROTOR (Ø30 x 36 x 2,5 mm)	1	HSOXXX00N1031S	<a href="#">XB92</a>
7	Kugellager - B.BEARING 1526 ESB/ESNB L	2	HSBXXX00N3741S	<a href="#">XB93</a>
8	HR Achse - RW AXLE AL XXX mm Ø15/52,85 mm EXP	1	HCCXXX00S3303S	<a href="#">XB94</a>
9	HR Endanschlag rechts - RW ADAPT WP XXX/12 R BM SRAM XD	1	HWAXXX00S2767S	<a href="#">XB95</a>
10	Freilaufkörper - FB W MTB SRA XD EXP AL ST SL M	1	HWRABL00S3830S	<a href="#">XB96</a>

	BESCHREIBUNG	ART. NR. DT SWISS	ART. NR. ORBEA
<b>Montagefett</b>	DT Swiss Universalfett 20 g	HXTXXX00NMG20S	<a href="#">XB72</a>
	DT Swiss Spezialfett 20 g	HXT10032508S	<a href="#">XB97</a>
<b>Werkzeuge</b>	Montagehülse 15 x 26 x 40 mm	HWTXXX00N5290S	<a href="#">XB98</a>
	Montage-/Demontagewerkzeug für Zahnscheibe mit Gewinde	HXTXXX00N9793S	<a href="#">XB99</a>
	Montage-/Demontagewerkzeug Kugellager Antriebsseite	HWTXXX00N5290S	<a href="#">XC01</a>
	Montagewerkzeug für Nabendichtung	HXTXXX00N9793S	<a href="#">XC02</a>

Für Online-Bestellung die Teilenummer anklicken. Naben-Ersatzteile sind ausschließlich für Orbea-Händler über Kide (B2B-Zugang) erhältlich.

## DT SWISS HINTERRADNABEN

## DT Swiss 350 J-bend 12x148 28/32-Loch Centerlock/6-Loch

In der Tabelle mit den technischen Daten der OQUO-Laufräder findest du Angaben zum Nabenmodell in deinen Laufrädern

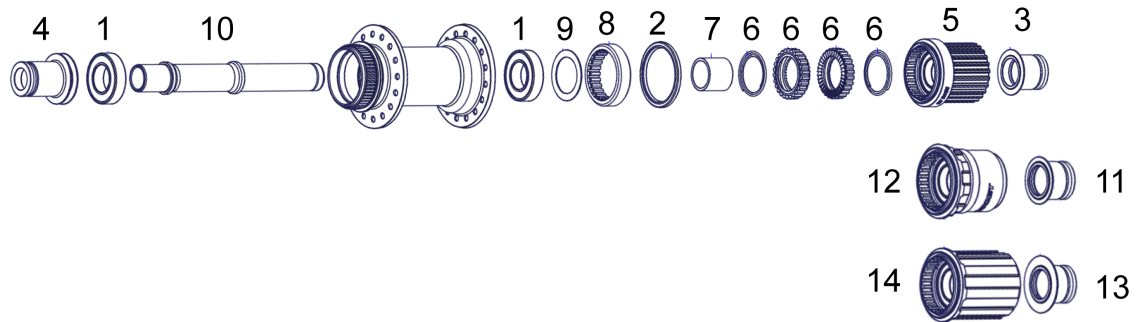

	BESCHREIBUNG	ANZAHL PRO NABE	ART. NR. DT SWISS	ART. NR. ORBEA
1	B.BEARING 6902 ESB/ESNB L	2	HSBXXX00N2336S	<a href="#">XC06</a>
2	SEAL HUB/ROTOR (diam 30x36x2.5mm)	1	HSOXXX00N1031S	<a href="#">XB92</a>
3	RW ADAPT WP XXX/12 R B MS	1	HWA00100S7912S	<a href="#">XC15</a>
4	RW ADAPT WP XXX/12 L B	1	HWA00100S7841S	<a href="#">XC17</a>
5	FB W MTB SHI MS RAT AL LI SL B	1	HWRABL00S2148S	<a href="#">XC19</a>
6	SERVICE KIT RATCHET 36T SL	1	HWTXXX00NSK36S	<a href="#">XC20</a>
7	SPACER ALLOY 15.4 mm BL	1	HCDXXX00S1077S	<a href="#">XC21</a>
8	RING NUT STEEL M34X1 240	1	HXDXXX00N1131S	<a href="#">XC22</a>
9	SHIM RING diam 28/20X0.5mm	1	HCDXXX00S1083S	<a href="#">XC23</a>
10	RW AXLE AL 148mm diam 15/48.2mm	1	HCCXXX00S6450S	<a href="#">XC24</a>
11	RW ADAPT WP XXX/12 R B SRAM XD	1	HWA00100S7513S	<a href="#">XC25</a>
12	FB W MTB SRA XD RAT AL ST SL B	1	HWRAL00S3114S	<a href="#">XC26</a>
13	RW ADAPT WP XXX/12 R B	1	HWA00100S7892S	<a href="#">XC27</a>
14	FB W MTB SHI RAT AL LI SL B	1	HWRABL00S1239S	<a href="#">XC28</a>

	BESCHREIBUNG	ART. NR. DT SWISS	ART. NR. ORBEA
<b>Montagefett</b>	DT Swiss Universalfett 20 g	HXTXXX00NMG20S	<a href="#">XB72</a>
	DT Swiss Spezialfett 20 g	HXT10032508S	<a href="#">XB97</a>
<b>Werkzeuge</b>	Montagehülse 15 x 26 x 40 mm	HWTXXX00N5290S	<a href="#">XB98</a>
	Montagewerkzeug für Nabendichtung	HXTXXX00N1000S	<a href="#">XC02</a>
	Werkzeug für Ringmutter	HXTXXX00N5027S	<a href="#">XC32</a>

Für Online-Bestellung die Teilenummer anklicken. Naben-Ersatzteile sind ausschließlich für Orbea-Händler über Kide (B2B-Zugang) erhältlich.

## DT SWISS HINTERRADNABEN

## DT Swiss 370 J-bend 12x148 28-Loch 6-Loch

In der Tabelle mit den technischen Daten der OQUO-Laufräder findest du Angaben zum Nabenmodell in deinen Laufrädern

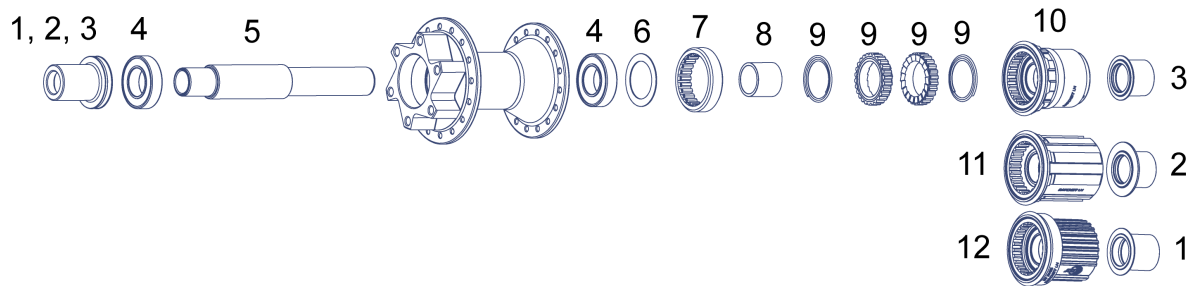

	BESCHREIBUNG	ANZAHL PRO NABE	ART. NR. DT SWISS	ART. NR. ORBEA
1	HR-UMRÜST-KIT XXX/12 B MS	1	HWGXXX00S5643S	X647
2	UMRÜST-KIT X12 HG	2	HWGXXX0002193C	X648
3	HR-UMRÜST-KIT 142/Ø12 240 SRAM XD	1	HWGXXX00S3188S	X649
4	Kugellager - B.BEARING 6902 ESB/ESNB M	1	HSBXXX00N3221S	XC06
5	Hinterradachse - RW AXLE AL 148 mm Ø15/48,2 mm	1	HCCXXX00S6450S	XC24
6	Passscheibe - SHIM RING Ø28/20 X 0,5 mm	1	HCDXXX00S1083S	XC23
7	Ringmutter - RING NUT STEEL M34X1 240	2	HXDXXX00N1131S	XC22
8	Distanzhülse - SPACER ALLOY 15.4 (ROTOR S)	2	HRDXXX00N4636S	XC35
9	SERVICE-KIT H240/240S/FR/440	1	HWTXXX00NSK24S	X650
10	FB K MTB SRA XD LN 12/142/48 AL ST SM B	1	HWYABM00S3766S	X651
11	FB K MTB SHI LN 12/142/48 AF ST SM B	1	HWYABM00S3764S	X653
12	FB K MTB SHI MS LN 12/142/48 AL LI SM B	1	HWYABM00S3765S	X652

	BESCHREIBUNG	ART. NR. DT SWISS	ART. NR. ORBEA
<b>Montagefett</b>	DT Swiss Universalfett 20 g	HXTXXX00NMG20S	XB72
	DT Swiss Spezialfett 20 g	HXT10032508S	XB97
<b>Werkzeuge</b>	Montagehülse 15 x 26 x 40 mm	HWTXXX00N5290S	XB98
	Montagewerkzeug für Nabendichtung	HXTXXX00N1000S	XC02
	Werkzeug für Ringmutter	HXTXXX00N5027S	XC32

Für Online-Bestellung die Teilenummer anklicken. Naben-Ersatzteile sind ausschließlich für Orbea-Händler über Kide (B2B-Zugang) erhältlich.

**DT SWISS HINTERRADNABEN****DT Swiss 350 Hybrid J-bend 12x148 32-Loch 6-Loch (bis MJ 2023)**

In der Tabelle mit den technischen Daten der OQUO-Laufräder findest du Angaben zum Nabenmodell in deinen Laufrädern

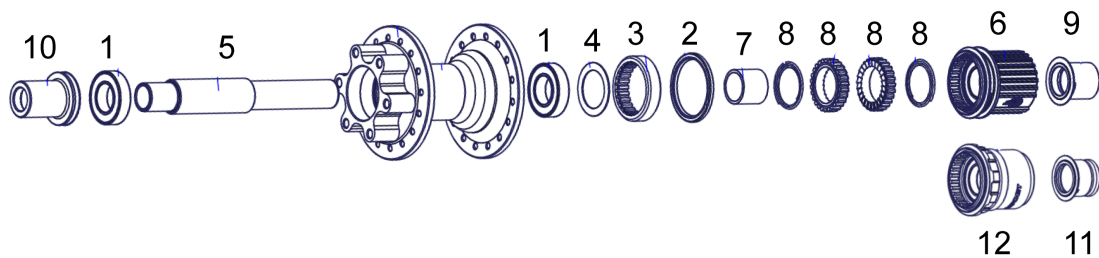

	BESCHREIBUNG	ANZAHL PRO NABE	ART. NR. DT SWISS	ART. NR. ORBEA
1	Kugellager - B.BEARING 6902 ESB/ESNB L	2	HSBXXX00N2336S	<a href="#">XC06</a>
2	Dichtung Nabe/Rotor - SEAL HUB/ROTOR (Ø30 x 36 x 2,5 mm)	1	HSOXXX00N1031S	<a href="#">XB92</a>
3	Ringmutter - RING NUT STEEL M34X1 240	1	HXDXXX00N1131S	<a href="#">XC22</a>
4	Passscheibe - SHIM RING Ø28/20 X 0,5 mm	1	HCDXXX00S1083S	<a href="#">XC23</a>
5	Hinterradachse - RW AXLE AL 148 mm Ø15/48,2 mm	1	HCCXXX00S6450S	<a href="#">XC24</a>
6	Freilaufkörper - FB W MHY SHI MS RAT ST ST SL B	1	HWRABL00S0758S	<a href="#">XC34</a>
7	Distanzhülse - SPACER ALLOY 15.4 (ROTOR S)	1	HRDXXX00N4636S	<a href="#">XC35</a>
8	Wartungskit - SERVICE KIT RATCHET 24T	1	HWTXXX00NSKTFS	<a href="#">XC36</a>
9	HR Endanschlag rechts - RW ADAPT WP XXXR TA12 B MS	1	HWAXXX00S0491S	<a href="#">XC37</a>
10	HR Endanschlag links - RW ADAPT WP 142L DBIS SA12 S	1	HWA00100S2193C	<a href="#">XC38</a>
11	HR Endanschlag rechts - RW ADAPT WP XXXR TA12 B SRAM XD	1	HWAXXX00S3188S	<a href="#">XC39</a>
12	Freilaufkörper - FB W MHY SRA XD RAT ST ST SL B	1	HWRAXL00S3224S	<a href="#">XC40</a>

	BESCHREIBUNG	ART. NR. DT SWISS	ART. NR. ORBEA
<b>Montagefett</b>	DT Swiss Universalfett 20 g	HXTXXX00NMG20S	<a href="#">XB72</a>
	DT Swiss Spezialfett 20 g	HXT10032508S	<a href="#">XB97</a>
<b>Werkzeuge</b>	Montagewerkzeug für Nabendichtung	HXTXXX00N1000S	<a href="#">XC02</a>
	Werkzeug für Ringmutter	HXTXXX00N5027S	<a href="#">XC32</a>
	Montagehülse Ø15 / 28 x 35 mm	HXTXXX00N5024S	<a href="#">XC41</a>

Für Online-Bestellung die Teilenummer anklicken. Naben-Ersatzteile sind ausschließlich für Orbea-Händler über Kide (B2B-Zugang) erhältlich.

## DT SWISS HINTERRADNABEN

## DT Swiss 350 Hybrid J-bend 12x148 32-Loch 6-Loch (ab MJ 2024)

In der Tabelle mit den technischen Daten der OQUO-Laufräder findest du Angaben zum Nabenmodell in deinen Laufrädern

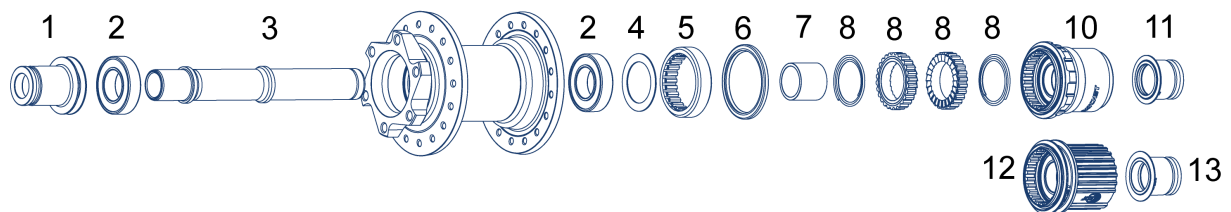

	BESCHREIBUNG	ANZAHL PRO NABE	ART. NR. DT SWISS	ART. NR. ORBEA
1	HR Endanschlag links - RW ADAPT WP XXX/12 L B	1	HWA00100S7841S	XC17
2	Kugellager - B.BEARING 6902 ESB/ESNB L	2	HSBXXX00N2336S	XC06
3	Hinterradachse - RW AXLE AL 148 mm Ø15/48,2 mm	1	HCCXXX00S6450S	XC24
4	Passscheibe - SHIM RING Ø28/20 X 0,5 mm	1	HCDXXX00S1083S	XC23
5	Ringmutter - RING NUT STEEL M34X1 240	1	HXDXXX00N1131S	XC22
6	Dichtung Nabe/Rotor - SEAL HUB/ROTOR (Ø30x36x2.5 mm)	1	HSOXXX00N1031S	XB92
7	Distanzhülse - SPACER ALLOY 15,4 mm BL	1	HCDXXX00S1077S	XC21
8	Wartungskit - SERVICE KIT RATCHET 24T	1	HWTXXX00NSKTFS	XC36
10	Freilaukörper - FB W MHY SRA XD RAT ST ST SL B	1	HWRAXL00S3224S	XC40
11	HR Endanschlag rechts - RW ADAPT WP XXX/12 R B SRAM XD	1	HWA00100S7513S	XC25
12	Freilaukörper - FB W MHY SHI MS RAT ST ST SL B	1	HWRABL00S3226S	XC34
13	HR Endanschlag rechts - RW ADAPT WP XXX/12 R B MS	1	HWA00100S7912S	XC15

	BESCHREIBUNG	ART. NR. DT SWISS	ART. NR. ORBEA
<b>Montagefett</b>	DT Swiss Universalfett 20 g	HXTXXX00NMG20S	XB72
	DT Swiss Spezialfett 20 g	HXT10032508S	XB97
<b>Werkzeuge</b>	Montagewerkzeug für Nabendichtung	HXTXXX00N1000S	XC02
	Werkzeug für Ringmutter	HXTXXX00N5027S	XC32
	Montagehülse Ø15 / 28 x 35 mm	HXTXXX00N5024S	XC41

Für Online-Bestellung die Teilenummer anklicken. Naben-Ersatzteile sind ausschließlich für Orbea-Händler über Kide (B2B-Zugang) erhältlich.

## SPEICHEN. SPEICHENSÄTZE FÜR OQUO-LAUFRÄDER

## MOUNTAIN PERFORMANCE (MP)

LAUFRAD-MODELL	VORDERRAD/ HINTERRAD	NABE	BESCHREIBUNG ERSATZTEIL	INHALT	ANZ.	ARTIKELCODE ORBEA
MP30 LTD V1 bis MJ 2024	VORDERRAD 29" 24 LOCH	DT SWISS 240 CLASSIC 24 LOCH	SATZ SPEICHEN + SPEICHENNIPPEL MP30 LTD VR 24- LOCH V1	Sapim CX-Ray TCS Aero. 14G (2 mm). J-Bend. 293 mm. Schwarz	2	XB61
				Sapim CX-Ray TCS Aero. 14G (2 mm). J-Bend. 291 mm. Schwarz	2	
				Sapim Alloy Double Square 2 x 18 mm. Schwarz	4	
	VORDERRAD 29" 28-LOCH	DT SWISS 240 CLASSIC 28- LOCH	SATZ SPEICHEN + SPEICHENNIPPEL MP30 LTD VR 28- LOCH V1	Sapim CX-Ray TCS Aero. 14G (2 mm). J-Bend. 299 mm. Schwarz	2	XB65
				Sapim CX-Ray TCS Aero. 14G (2 mm). J-Bend. 297 mm. Schwarz	2	
				Sapim Alloy Double Square 2 x 18 mm. Schwarz	4	
	HINTERRAD 29" 28-LOCH	DT SWISS 240 CLASSIC 28- LOCH	SATZ SPEICHEN + SPEICHENNIPPEL MP30 LTD HR 28- LOCH V1	Sapim CX-Ray TCS Aero. 14G (2 mm). J-Bend. 295 mm. Schwarz	2	XB86
				Sapim CX-Ray TCS Aero. 14G (2 mm). J-Bend. 296 mm. Schwarz	2	
				Sapim Alloy Double Square 2 x 18 mm. Schwarz	4	
MP30 LTD V2 ab MJ 2025	VORDERRAD 29" 24 LOCH	OQUO LTD SP DT SWISS INSIDE 240 24- LOCH	SATZ SPEICHEN + SPEICHENNIPPEL MP30 LTD VR 24- LOCH V2	DT aerolite T-shape Straightpull 2,0-(0,9x2,2)-2 mm. 301 mm. Schwarz	4	XH58
				DT Aluminium Double Square 2x15 mm.	4	
	HINTERRAD 29" 28-LOCH	OQUO LTD SP DT SWISS INSIDE 240 28- LOCH	SATZ SPEICHEN + SPEICHENNIPPEL MP30 LTD HR 28- LOCH V2	DT Aerolite T-shape Straightpull 2,0-(0,9x2,2)-2 mm. 304 mm. Schwarz	4	XH59
				DT Aluminium Double Square 2x15 mm.	4	
MP30 TEAM V1 bis MJ 2024	VORDERRAD 29" 28-LOCH	DT SWISS 350 CLASSIC 28- LOCH	SATZ SPEICHEN + SPEICHENNIPPEL MP30 TEAM VR 28-LOCH V1	Sapim D-Sprint. Konifiziert. 14G (2 mm).J-Bend. 298 mm. Schwarz	2	XC03
				Sapim D-Sprint. Konifiziert. 14G (2 mm).J-Bend. 297 mm. Schwarz	2	
				Sapim Brass Polyax 2 x 14 mm. Schwarz	4	
	HINTERRAD 29" 28-LOCH	DT SWISS 350 CLASSIC 28- LOCH	SATZ SPEICHEN + SPEICHENNIPPEL MP30 TEAM HR 28-LOCH V1	Sapim D-Sprint. Konifiziert. 14G (2 mm).J-Bend. 294 mm. Schwarz	2	XC12
				Sapim D-Sprint. Konifiziert. 14G (2 mm).J-Bend. 295 mm. Schwarz	2	
				Sapim Brass Polyax 2 x 14 mm. Schwarz	4	
MP30 TEAM V2 ab MJ 2025	VORDERRAD 29" 28-LOCH	OQUO TEAM SP DT SWISS INSIDE 350 28- LOCH	SATZ SPEICHEN + SPEICHENNIPPEL MP30 TEAM VR 28-LOCH V2	Sapim Sprint SP konifiziert 2,0/1,7/2,0 305 mm. Schwarz	4	XH61
				Sapim Alloy Double Square 2 x 18 mm. Schwarz	4	
	HINTERRAD 29" 28-LOCH	OQUO TEAM SP DT SWISS INSIDE 350 28- LOCH	SATZ SPEICHEN + SPEICHENNIPPEL MP30 TEAM HR 28-LOCH V2	Sapim Sprint SP konifiziert 2,0/1,7/2,0 304 mm. Schwarz	4	XH62
				Sapim Alloy Double Square 2 x 18 mm. Schwarz	4	
MP28 PRO bis zu MY2023	VORDERRAD 29" 28-LOCH	DT SWISS 350 CLASSIC 28- LOCH	SATZ SPEICHEN + SPEICHENNIPPEL MP28 PRO VR 28- LOCH V1	Sapim Race. Konifiziert. 14G (2 mm).J-Bend. 298 mm. Schwarz	2	XC33
				Sapim Race. Konifiziert. 14G (2 mm). J-Bend. 297 mm. Schwarz	2	
				Sapim Brass Polyax 2 x 14 mm. Schwarz	4	
	HINTERRAD 29" 28-LOCH	DT SWISS 350 CLASSIC 28- LOCH	SATZ SPEICHEN + SPEICHENNIPPEL MP28 PRO HR 28- LOCH V1	Sapim Race. Konifiziert. 14G (2 mm).J-Bend. 296 mm. Schwarz	2	XC14
				Sapim Race. Konifiziert. 14G (2 mm). J-Bend. 297 mm. Schwarz	2	
				Sapim Brass Polyax 2 x 14 mm. Schwarz	4	
MP28 PRO ab MJ2024	VORDERRAD 29" 28-LOCH	DT SWISS 370 CLASSIC 28- LOCH	SATZ SPEICHEN + SPEICHENNIPPEL MP28 PRO VR 28- LOCH V2	Sapim Race. Konifiziert. 14G (2 mm). J-Bend. 297 mm. Schwarz	2	XD46
				Sapim Race. Konifiziert. 14G (2 mm). J-Bend. 296 mm. Schwarz	2	
				Sapim Brass Polyax 2 x 14 mm. Schwarz	4	
	HINTERRAD 29" 28-LOCH	DT SWISS 370 CLASSIC 28- LOCH	SATZ SPEICHEN + SPEICHENNIPPEL MP28 PRO HR 28- LOCH V2	Sapim Race. Konifiziert. 14G (2 mm). J-Bend. 296 mm. Schwarz	2	XD47
				Sapim Race. Konifiziert. 14G (2 mm). J-Bend. 296 mm. Schwarz	2	
				Sapim Brass Polyax 2 x 14 mm. Schwarz	4	

Für Online-Bestellung die Teilenummer anklicken.

## SPEICHEN. SPEICHENSÄTZE FÜR OQUO-LAUFRÄDER

## MOUNTAIN CONTROL (MC)

LAUFRAD-MODELL	VORDERRAD/ HINTERRAD	NABE	BESCHREIBUNG ERSATZTEIL	INHALT	ANZ.	ARTIKELCODE ORBEA
<b>MC32 LTD V1</b> bis MJ 2025	VORDERRAD 29" 28-LOCH	DT SWISS 350 CLASSIC 28-LOCH	SATZ SPEICHEN + SPEICHENNIPPEL MC32 LTD VR 28-LOCH V1	Sapim D-Sprint. Konifiziert. 14G (2 mm).J-Bend. 298 mm. Schwarz	2	XC29
				Sapim D-Sprint. Konifiziert. 14G (2 mm). J-Bend. 301 m. Schwarz	2	
				Sapim Brass Polyax 2 x 14 mm. Schwarz	4	
	HINTERRAD 29" 32-LOCH	DT SWISS 350 CLASSIC 32-LOCH	SATZ SPEICHEN + SPEICHENNIPPEL MC32 LTD HR 32-LOCH V1	Sapim Race. Konifiziert. 14G (2 mm).J-Bend. 292 mm. Schwarz	4	XC30
			Sapim Brass Polyax 2 x 14 mm. Schwarz	4		
<b>MC32 LTD V2</b> ab MJ 2026	VORDERRAD 29" 28-LOCH	OQUO LTD JBEND 28-LOCH DT INSIDE 350	SATZ SPEICHEN + SPEICHENNIPPEL MC32 LTD VR 28-LOCH V2	Sapim Sprint Konifiziert. 14G (2 mm).J-Bend. 299 mm. Schwarz	4	XJ99
				Sapim Brass Polyax 2 x 14 mm. Schwarz	4	
	HINTERRAD 29" 32-LOCH	OQUO LTD JBEND 32-LOCH DT INSIDE 350 DEG	SATZ SPEICHEN + SPEICHENNIPPEL MC32 LTD HR 32-LOCH V2	Sapim Race. Konifiziert. 14G (2 mm).J-Bend. 291 mm. Schwarz	4	XK00
				Sapim Brass Polyax 2 x 14 mm. Schwarz	4	
<b>MC32 TEAM V1</b> bis MJ 2024	VORDERRAD 29" 28-LOCH	DT SWISS 350 CLASSIC 28-LOCH	SATZ SPEICHEN + SPEICHENNIPPEL MC32 TEAM VR 28-LOCH V1	Sapim D-Sprint. Konifiziert. 14G (2 mm).J-Bend. 299 mm. Schwarz	2	XC42
				Sapim D-Sprint. Konifiziert. 14G (2 mm). J-Bend. 297 m. Schwarz	2	
				Sapim Brass Polyax 2 x 14 mm. Schwarz	4	
	HINTERRAD 29" 32-LOCH	DT SWISS 350 CLASSIC 32-LOCH	SATZ SPEICHEN + SPEICHENNIPPEL MC32 TEAM HR 29 32-LOCH V1	Sapim Race. Konifiziert. 14G (2 mm).J-Bend. 291 mm. Schwarz	4	XC43
				Sapim Brass Polyax 2 x 14 mm. Schwarz	4	
	HINTERRAD 27,5" 32-LOCH	DT SWISS 350 CLASSIC 32-LOCH	SATZ SPEICHEN + SPEICHENNIPPEL MC32 TEAM HR 27,5 32-LOCH V1	Sapim Race. Konifiziert. 14G (2 mm).J-Bend. 271 mm. Schwarz	4	XC44
Sapim Brass Polyax 2 x 14 mm. Schwarz				4		
<b>MC32 TEAM V2</b> MJ 2025	VORDERRAD 29" 28-LOCH	DT SWISS 350 CLASSIC 28-LOCH	SATZ SPEICHEN + SPEICHENNIPPEL MC32 TEAM VR 28-LOCH V2	Sapim D-Light konifiziert. 14G (2 mm). J-Bend. 302 mm. Schwarz	2	XH63
				Sapim D-Light konifiziert. 14G (2 mm). J-Bend. 300 mm. Schwarz	2	
				Sapim Alloy Double Square 2 x 18 mm. Schwarz	4	
	HINTERRAD 29" 32-LOCH	DT SWISS 350 CLASSIC 32-LOCH	SATZ SPEICHEN + SPEICHENNIPPEL MC32 TEAM HR 29 32-LOCH V2	Sapim Sprint Konifiziert. 14G (2 mm).J-Bend. 295 mm. Schwarz	4	XH64
				Sapim Alloy Double Square 2 x 18 mm. Schwarz	4	
	HINTERRAD 27,5" 32-LOCH	DT SWISS 350 CLASSIC 32-LOCH	SATZ SPEICHEN + SPEICHENNIPPEL MC32 TEAM HR 27,5 32-LOCH V2	Sapim Sprint Konifiziert. 14G (2 mm).J-Bend. 276 mm. Schwarz	4	XH65
Sapim Alloy Double Square 2 x 18 mm. Schwarz				4		
<b>MC32 TEAM V3</b> ab MJ 2026	VORDERRAD 29" 28-LOCH	OQUO LTD JBEND 28-LOCH DT INSIDE 350	SATZ SPEICHEN + SPEICHENNIPPEL MC32 TEAM VR 28-LOCH V3	Sapim D-Light. Konifiziert. 14G (2 mm).J-Bend. 298 mm. Schwarz	2	XK02
				Sapim D-Light. Konifiziert. 14G (2 mm). J-Bend. 297 mm. Schwarz	2	
				Sapim Alloy Double Square 2 x 18 mm. Schwarz	4	
	HINTERRAD 29" 32-LOCH	OQUO LTD JBEND 32-LOCH DT INSIDE 350 DEG	SATZ SPEICHEN + SPEICHENNIPPEL MC32 TEAM HR 29 32-LOCH V3	Sapim Sprint Konifiziert. 14G (2 mm). J-Bend. 291 m. Schwarz	4	XK03
				Sapim Alloy Double Square 2 x 18 mm. Schwarz	4	
	HINTERRAD 27,5" 32-LOCH	OQUO LTD JBEND 32-LOCH DT INSIDE 350 DEG	SATZ SPEICHEN + SPEICHENNIPPEL MC32 TEAM HR 27,5 32-LOCH V3	Sapim Sprint Konifiziert. 14G (2 mm). J-Bend. 272 m. Schwarz	4	XK04
Sapim Alloy Double Square 2 x 18 mm. Schwarz				4		
<b>MC32 TEAM RALLON DH (OEM)</b> ab MJ 2026	VORDERRAD 29" 28-LOCH	DT SWISS 350 CLASSIC 28-LOCH	SATZ SPEICHEN + SPEICHENNIPPEL MC32 TEAM RALLON DH VR 28-LOCH (OEM) V1	Sapim Race. Konifiziert. 14G (2 mm).J-Bend. 296 mm. Schwarz	4	XK05
				Sapim Brass Polyax 2 x 14 mm. Schwarz	4	
	HINTERRAD 27,5" 32-LOCH	DT SWISS 350 CLASSIC 32-LOCH	SATZ SPEICHEN + SPEICHENNIPPEL MC32 TEAM RALLON DH HR 27,5 32-LOCH (OEM) V1	Sapim Race. Konifiziert. 14G (2 mm).J-Bend. 272 mm. Schwarz	4	XK06
				Sapim Brass Polyax 2 x 14 mm. Schwarz	4	

## SPEICHEN. SPEICHENSÄTZE FÜR OQUO-LAUFRÄDER

## MOUNTAIN CONTROL (MC) POWER

LAUFRAD-MODELL	VORDERRAD/ HINTERRAD	NABE	BESCHREIBUNG ERSATZTEIL	INHALT	ANZ.	ARTIKELCODE ORBEA
MC32 LTD POWER bis zu MY2023	HINTERRAD 29" 32-LOCH	DT SWISS 350 HYBRID CLASSIC 32- LOCH bis zu MY2023	SATZ SPEICHEN + SPEICHENNIPPEL MC32 LTD POWER HR 32- LOCH V1	Sapim E-Light. Konifiziert. 14G (2 mm).J-Bend. 292 mm. Schwarz	2	XC31
				Sapim E-Light. Konifiziert. 14G (2 mm). J-Bend. 294 mm. Schwarz	2	
				Sapim Brass Polyax 2 x 14 mm. Schwarz	4	
MC32 LTD POWER von MY2024	VORDERRAD 29" 28-LOCH	DT SWISS 350 HYBRID CLASSIC 28- LOCH von MY2024	SATZ SPEICHEN + SPEICHENNIPPEL MC32 LTD POWER VR 28- LOCH V2	Sapim E-Light. Konifiziert 14G (2 mm).J-Bend. 298 mm. Schwarz	2	XD49
				Sapim E-Light. Konifiziert. 14G (2 mm). J-Bend. 299 mm. Schwarz	2	
				Sapim Brass Polyax 2 x 14 mm. Schwarz	4	
	HINTERRAD 29" 32-LOCH	DT SWISS 350 HYBRID CLASSIC 32- LOCH von MY2024	SATZ SPEICHEN + SPEICHENNIPPEL MC32 LTD POWER HR 32- LOCH V2	Sapim E-Light. Konifiziert 14G (2 mm).J-Bend. 292 mm. Schwarz	2	XD50
				Sapim E-Light. Konifiziert. 14G (2 mm). J-Bend. 291 mm. Schwarz	2	
				Sapim Brass Polyax 2 x 14 mm. Schwarz	4	
MC32 TEAM POWER V1 bis MJ 2023	VORDERRAD 29" 32-LOCH	DT SWISS 350 HYBRID CLASSIC 32- LOCH bis zu MY2023	SATZ SPEICHEN + SPEICHENNIPPEL MC32 TEAM POWER VR 32- LOCH V1	Sapim E-Light. Konifiziert. 14G (2 mm).J-Bend. 292 mm. Schwarz	2	XC45
				Sapim E-Light. Konifiziert. 14G (2 mm). J-Bend. 294 m. Schwarz	2	
				Sapim Brass Polyax 2 x 14 mm. Schwarz	4	
	HINTERRAD 29" 32-LOCH	DT SWISS 350 HYBRID CLASSIC 32- LOCH bis zu MY2023	SATZ SPEICHEN + SPEICHENNIPPEL MC32 TEAM POWER HR 32- LOCH V1	Sapim E-Light. Konifiziert. 14G (2 mm).J-Bend. 291 mm. Schwarz	2	XC49
				Sapim E-Light. Konifiziert. 14G (2 mm). J-Bend. 293 mm. Schwarz	2	
				Sapim Brass Polyax 2 x 14 mm. Schwarz	4	
MC32 TEAM POWER V2 ab MJ 2024	VORDERRAD 29" 28-LOCH	DT SWISS 350 HYBRID CLASSIC 28- LOCH von MY2024	SATZ SPEICHEN + SPEICHENNIPPEL MC32 TEAM POWER VR 28- LOCH V2	Sapim E-Light. Konifiziert. 14G (2 mm).J-Bend. 297 mm. Schwarz	2	XD51
				Sapim E-Light. Konifiziert. 14G (2 mm).J-Bend. 298 mm. Schwarz	2	
				Sapim Brass Polyax 2 x 14 mm. Schwarz	4	
	HINTERRAD 29" 32-LOCH	DT SWISS 350 HYBRID CLASSIC 32- LOCH von MY2024	SATZ SPEICHEN + SPEICHENNIPPEL MC32 TEAM POWER HR 29 32- LOCH V2	Sapim E-Light. Konifiziert. 14G (2 mm).J-Bend. 291 mm. Schwarz	2	XD52
				Sapim E-Light. Konifiziert. 14G (2 mm).J-Bend. 292 mm. Schwarz	2	
				Sapim Brass Polyax 2 x 14 mm. Schwarz	4	
	HINTERRAD 27,5" 32-LOCH	DT SWISS 350 HYBRID CLASSIC 32- LOCH von MY2024	SATZ SPEICHEN + SPEICHENNIPPEL MC32 TEAM POWER HR 27,5 32-LOCH V2	Sapim E-Light. Konifiziert. 14G (2 mm).J-Bend. 271 mm. Schwarz	4	XD54
				Sapim Brass Polyax 2 x 14 mm. Schwarz	4	
	MC32 TEAM POWER V3 MJ 2025	VORDERRAD 29" 28-LOCH	DT SWISS 350 HYBRID CLASSIC 28- LOCH von MY2024	SATZ SPEICHEN + SPEICHENNIPPEL MC32 TEAM POWER VR 28- LOCH V3-V4	Sapim E-Light. Konifiziert. 14G (2 mm).J-Bend. 301 mm. Schwarz	2
Sapim E-Light. Konifiziert. 14G (2 mm).J-Bend. 300 mm. Schwarz					2	
Oquo Nippel eloxiert 2 x 18 mm + Unterlegscheiben					4	
HINTERRAD 29" 32-LOCH		DT SWISS 350 HYBRID CLASSIC 32- LOCH von MY2024	SATZ SPEICHEN + SPEICHENNIPPEL MC32 TEAM POWER HR 29 32- LOCH V3-V4	Sapim E-Light. Konifiziert 14G (2 mm).J-Bend. 294 mm. Schwarz	2	XH72
				Sapim E-Light. Konifiziert. 14G (2 mm).J-Bend. 295 mm. Schwarz	2	
				Oquo Nippel eloxiert 2 x 18 mm + Unterlegscheiben	4	
HINTERRAD 27,5" 32-LOCH		DT SWISS 350 HYBRID CLASSIC 32- LOCH von MY2024	SATZ SPEICHEN + SPEICHENNIPPEL MC32 TEAM POWER HR 27,5 32-LOCH V3-V4	Sapim E-Light. Konifiziert. 14G (2 mm).J-Bend. 276 mm. Schwarz	2	XH73
				Sapim E-Light. Konifiziert. 14G (2 mm).J-Bend. 275 mm. Schwarz	2	
				Oquo Nippel eloxiert 2 x 18 mm + Unterlegscheiben	4	

Für Online-Bestellung die Teilenummer anklicken.

## SPEICHEN. SPEICHENSÄTZE FÜR OQUO-LAUFRÄDER

## MOUNTAIN CONTROL (MC) POWER

LAUFRAD-MODELL	VORDERRAD/ HINTERRAD	NABE	BESCHREIBUNG ERSATZTEIL	INHALT	ANZ.	ARTIKELCODE ORBEA
MC32 TEAM POWER V4 ab MJ 2026	VORDERRAD 29" 28-LOCH	DT SWISS 350 HYBRID CLASSIC 28- LOCH von MY2024	SATZ SPEICHEN + SPEICHENNIPPEL MC32 TEAM POWER VR 28- LOCH V3-V4	Sapim E-Light. Konifiziert. 14G (2 mm).J-Bend. 301 mm. Schwarz	2	XH71
				Sapim E-Light. Konifiziert. 14G (2 mm).J-Bend. 300 mm. Schwarz	2	
				Oquo Nippel eloxiert 2 x 18 mm + Unterlegscheiben	4	
	HINTERRAD 29" 32-LOCH	DT SWISS 350 HYBRID CLASSIC 32- LOCH von MY2024	SATZ SPEICHEN + SPEICHENNIPPEL MC32 TEAM POWER HR 29 32- LOCH V3-V4	Sapim E-Light. Konifiziert 14G (2 mm).J-Bend. 294 mm. Schwarz	2	XH72
				Sapim E-Light. Konifiziert. 14G (2 mm).J-Bend. 295 mm. Schwarz	2	
				Oquo Nippel eloxiert 2 x 18 mm + Unterlegscheiben	4	
	HINTERRAD 27,5" 32-LOCH	DT SWISS 350 HYBRID CLASSIC 32- LOCH von MY2024	SATZ SPEICHEN + SPEICHENNIPPEL MC32 TEAM POWER HR 27,5 32-LOCH V3-V4	Sapim E-Light. Konifiziert. 14G (2 mm).J-Bend. 276 mm. Schwarz	2	XH73
				Sapim E-Light. Konifiziert. 14G (2 mm).J-Bend. 275 mm. Schwarz	2	
				Oquo Nippel eloxiert 2 x 18 mm + Unterlegscheiben	4	

Für Online-Bestellung die Teilenummer anklicken.

## OQUO-TUBELESS-VENTILE

### Montage des Tubesless-Ventils bei asymmetrischen Felgen

Bei manchen OQUO-Felgen mit asymmetrischem Profil muss zwischen der Felge und der Ventilmutter ein asymmetrischer Adapter verwendet werden, um den korrekten Sitz des Ventils außen auf der Felge zu gewährleisten.

Dieser Adapter liegt allen OQUO-Laufrädern bei, für deren asymmetrisches Profil er erforderlich ist.

In der folgenden Tabelle mit den Ventilhöhen erfährst du, bei welchen OQUO-Laufradmodellen der asymmetrische Tubeless-Ventiladapter eingesetzt werden muss.

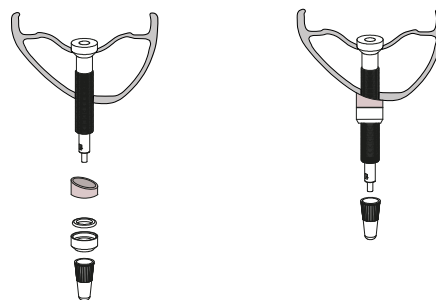

### Tubeless-Ventilhöhe

Die folgende Tabelle enthält Angaben zur Höhe des bei deinen OQUO-Laufrädern verbauten Tubeless-Ventils.

MODELLREIHE	LAUFRADMODELL	VENTILHÖHE		ASYMMETRISCHER VENTILADAPTER
		Vorderrad	Hinterrad	
MOUNTAIN PERFORMANCE	MP30LTD	44 mm	44 mm	NEIN
	MP30TEAM	44 mm	44 mm	NEIN
	MP28PRO	40 mm	40 mm	JA XB66
MOUNTAIN CONTROL	MC32LTD	44 mm	44 mm	NEIN
	MC32LTD POWER	44 mm	44 mm 57 mm beim Wild mit Ventilmagnet	NEIN
	MC32 TEAM V1 (bis MJ 2024)	44 mm	44 mm	JA XB66
	MC32 TEAM V2-V3 (ab MJ 2025)	44 mm	44 mm	JA XH67
	MC32 TEAM RALLON DH (ab MJ 2026)	44 mm	44 mm	JA XH67
	MC32 TEAM POWER V1 (bis MJ 2023)	44 mm	44 mm 57 mm beim Wild mit Ventilmagnet	JA XB66
MC32 TEAM POWER V2-V4 (ab MJ 2024)	44 mm	44 mm 57 mm beim Wild mit Ventilmagnet	JA XH67	



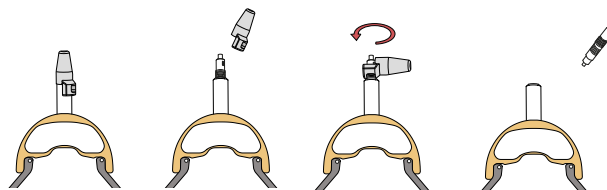

Für Online-Bestellung die Teilenummer anklicken.

### In die OQUO-Ventilkappe integriertes Werkzeug

Bei OQUO-Tubeless-Ventilen ist ein Werkzeug zum Entfernen des Tubeless-Ventileinsatzes in die Ventilkappe integriert.

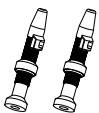

## OQUO-Zubehör

ART. NR.	BESCHREIBUNG	ANZ.	
X803	<b>OQUO TUBELESS-VENTIL-KIT 44 mm</b> Mit Ventilschlüssel	2	
X804	<b>OQUO TUBELESS-VENTIL-KIT 44 mm + 57 mm</b> Mit Ventilschlüssel Adapter für asymmetrische Felgen nicht enthalten		
XB67	<b>OQUO TUBELESS-VENTIL-KIT</b> Integrierter Ventilschlüssel	2	
XB66	<b>VENTILADAPTER-KIT V1 FÜR ASYMMETRISCHE FELGEN</b> In der Tabelle im vorherigen Abschnitt ist angegeben, ob der Adapter bei deinen OQUO-Laufrädern benötigt wird	2	
XH67	<b>VENTILADAPTER-KIT V2 FÜR ASYMMETRISCHE FELGEN</b> In der Tabelle im vorherigen Abschnitt ist angegeben, ob der Adapter bei deinen OQUO-Laufrädern benötigt wird	2	
XH28	<b>OQUO VENTILVERSCHLUSS-KIT</b>	10	

Für Online-Bestellung die Teilenummer anklicken.

---

## BAU VON OQUO-LAUFRÄDERN



Dieser Abschnitt bietet allgemeine Anweisungen zum Einspeichen und Fertigstellen von OQUO-Laufrädern für OQUO-Händler:innen, die eine OQUO-Felge nach Genehmigung durch OQUO ersetzen müssen. Er ist nicht als Leitfaden für den Laufradbau gedacht.

Um ein Laufrad fachgerecht und sicher zu bauen, bedarf es umfassender technischer Kompetenz und Erfahrung. Benutzer:innen und Techniker:innen, die nicht entsprechend geschult sind oder nicht über die nötige Erfahrung verfügen, sollten kein Laufrad zum späteren Gebrauch selbst bauen.



Eine nicht fachgerecht durchgeführte Laufradkonstruktion kann die strukturelle Integrität und Strapazierfähigkeit des Laufrads beeinträchtigen und zu einem nicht durch die Gewährleistung abgedeckten Versagen von Komponenten führen, was schwere oder gar tödliche Verletzungen zur Folge haben kann.

### WERKZEUGE

Im Abschnitt „Wartung von OQUO-Laufrädern“ wird beschrieben, welche Werkzeuge für die fachgerechte Wartung und den Bau von OQUO-Laufrädern erforderlich sind.

Verwende stets die richtigen Werkzeuge und Produkte für den Laufradbau. Ungeeignete oder schlecht gepflegte Werkzeuge, aber auch die Verwendung von Allzweckprodukten, können Schäden an Komponenten verursachen, die dann nicht unter die Gewährleistung fallen.

## ASYMMETRISCHE FELGEN

Bei Felgen mit asymmetrischem Profil (welche Modelle eine asymmetrische Felge besitzen, kannst du der Tabelle mit den technischen Daten in diesem Handbuch entnehmen) richte die Felge immer wie nachfolgend beschrieben aus.

### • Vorderradfelgen

Der Felgenversatz muss der Antriebsseite zugewandt sein.

### • Hinterradfelgen

Der Felgenversatz muss der Nichtantriebsseite zugewandt sein.

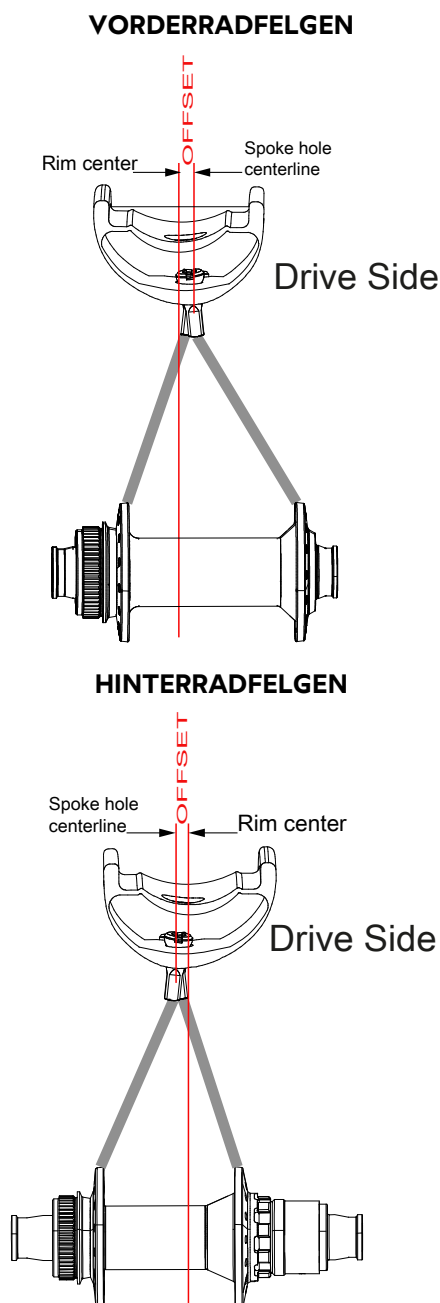

## SYMMETRISCHE FELGEN

Bei symmetrischen Felgen (ohne Versatz) richtest du die Felge so aus, dass alle Aufkleber von der gleichen Seite des Fahrrads aus lesbar sind wie auf dem Originalauftrad.

## DIREKTIONALE SPEICHENLÖCHER

Falls die Felge directionale Speichenlöcher besitzt, achte beim Laufradbau stets darauf, dass die Ausrichtung der Löcher in der Felge mit der entsprechenden Nabenseite übereinstimmt.

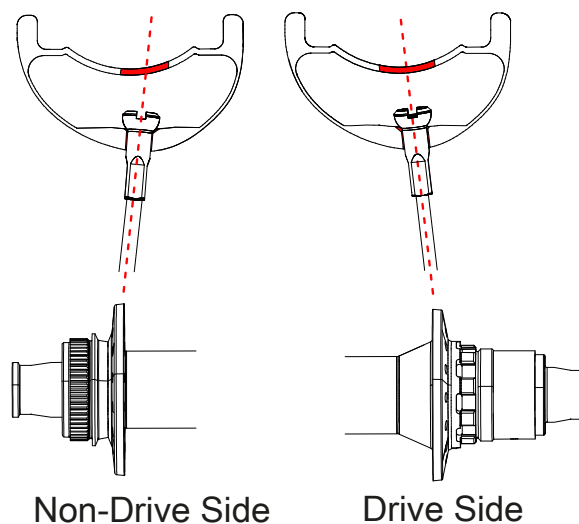

## SPEZIELLE VORDER- UND HINTERRADFELGEN

Achte bei OQUO-Modellen mit einer bestimmten Vorder- bzw. Hinterradfelge darauf, dass du die für das jeweilige Laufrad vorgesehene Felge verwendest.

In der Tabelle mit den technischen Daten in diesem Handbuch kannst du nachsehen, ob bei deinem Modell spezielle Vorder- und Hinterradfelgen verwendet werden.

Bei speziell für Vorderräder konzipierten Felgen ist der Buchstabe F im Namen des Felgenmodells enthalten.

Bei speziell für Hinterräder konzipierten Felgen ist der Buchstabe R im Namen des Felgenmodells enthalten.

Bei Felgen, die nicht vorder- oder hinterradspezifisch sind, ist der Buchstabe B im Namen des Felgenmodells enthalten.

## SPEICHEN UND NIPPEL

Verwende grundsätzlich die von OQUO für das Laufradmodell spezifizierten Speichen und Nippel.

Die Komponenten der einzelnen Modelle sind der Tabelle mit den technischen Daten in diesem Handbuch entnehmbar.

### STRAIGHTPULL-SPEICHEN KLASSISCH ODER MIT T-KOPF

Je nach Art der Speichenlöcher im Flansch der Straightpull-Nabe müssen entweder klassische Straightpull-Speichen oder solche mit T-Kopf montiert werden.

Bei Naben für Straightpull-Speichen mit T-Kopf sind die Speichenlöcher im Flansch rechteckig und umschließen den Speichenkopf, um diesen gegen Verdrehen und Lockern zu sichern.

Bei Naben für klassische Straightpull-Speichen sind die Speichenlöcher rund, daher müssen hier Speichen mit Standardkopf verwendet werden.

### STRAIGHTPULL-SPEICHEN MIT T-KOPF



### SPEICHENNIPPEL MIT UNTERLEGSCHLEIBEN

Manche Nippel werden mit Unterlegscheiben zwischen Nippel und Felgenwand montiert.

Überprüfe anhand der Datentabelle deines Laufrads, ob Unterlegscheiben montiert werden müssen.

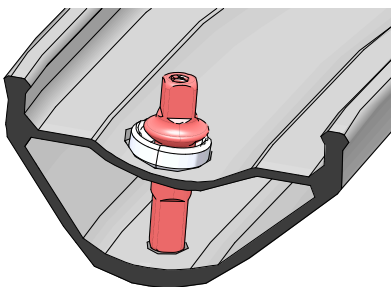

## SPEICHENMUSTER FÜR J-BEND-SPEICHEN



Anders als bei Laufradaufbauten mit J-Bend-Speichen ist das Speichenmuster bei Straightpull-Speichen durch die Nabe vorgegeben und kann beim Laufradbau nicht frei gewählt werden.

Befolge beim Einspeichen auf beiden Laufradseiten stets das ursprüngliche Speichenmuster.

Achte darauf, dass sich die Speichen korrekt kreuzen (oberhalb oder unterhalb).

### 3-FACH KREUZUNG

Jede Speiche kreuzt drei andere Speichen auf derselben Laufradseite, bevor sie an der Felge festgespannt wird.

Je nachdem, auf welcher Seite des Nabenflansches die Speiche austritt, gibt es zwei mögliche Varianten für ihre Positionierung gegenüber den anderen drei Speichen.

Wenn die Speiche an der Außenseite des Nabenflansches austritt, kreuzt sie die anderen Speichen folgendermaßen:

- 01** Oberhalb
- 02** Oberhalb
- 03** Unterhalb

Wenn die Speiche an der Innenseite des Nabenflansches austritt, kreuzt sie die anderen Speichen folgendermaßen:

- 01** Unterhalb
- 02** Unterhalb
- 03** Oberhalb

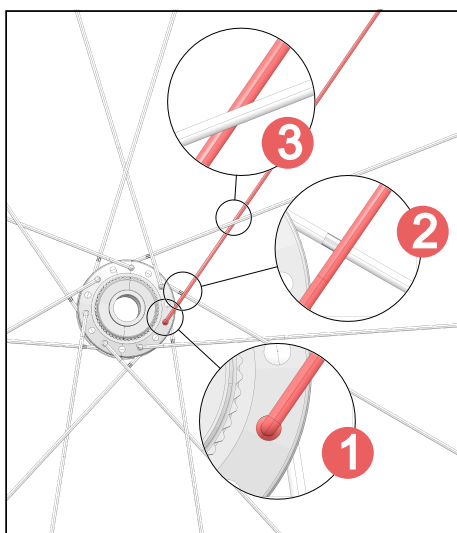

## 2-FACH KREUZUNG

Jede Speiche kreuzt zwei andere Speichen auf derselben Laufradseite, bevor sie an der Felge festgespannt wird.

Je nachdem, auf welcher Seite des Nabenflansches die Speiche austritt, gibt es zwei mögliche Varianten für ihre Positionierung gegenüber den anderen beiden Speichen.

Wenn die Speiche an der Außenseite des Nabenflansches austritt, kreuzt sie die anderen Speichen folgendermaßen:

- 01** Oberhalb
- 02** Unterhalb

Wenn die Speiche an der Innenseite des Nabenflansches austritt, kreuzt sie die anderen Speichen folgendermaßen:

- 01** Unterhalb
- 02** Oberhalb

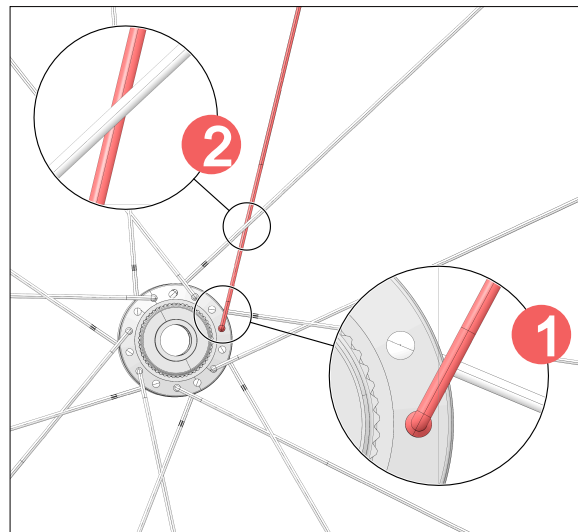

**POSITION VON DRUCK- UND ZUGSPEICHEN BEI VERWENDUNG VON J-BEND-SPEICHEN**



Bei Aufbauten mit Straightpull-Nabe und -Speichen ist die Position der Nabe und Speichen vorgegeben und kann beim Laufradbau nicht frei gewählt werden.

Überprüfe die Anordnung der Druck- und Zugspeichen in der Datentabelle in diesem Handbuch – oder auch am Originallauftrad – und speiche das Lauftrad dann auf beiden Laufradseiten entsprechend ein.

**Zugspeiche (Trailing)**

Zugspeichen verlassen die Nabe in entgegengesetzter Richtung zur Laufraddrehung.

**Druckspeiche (Leading)**

Druckspeichen verlassen die Nabe in Drehrichtung des Lauftrads.

Die folgenden Abbildungen zeigen Beispiele für Speichenmuster. Sieh dir das Speichenmuster am Originallauftrad an oder kontrolliere die diesbezügliche Angabe in der Datentabelle.

Laufrad-Drehrichtung

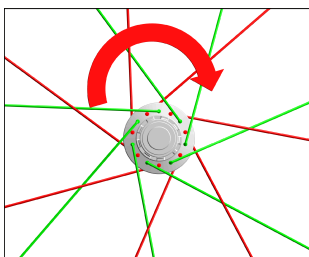

HINTERRAD ANTRIEBSSEITE

**Zugspeiche:** Außenseite des Nabenflansches  
**Druckspeiche:** Innenseite des Nabenflansches

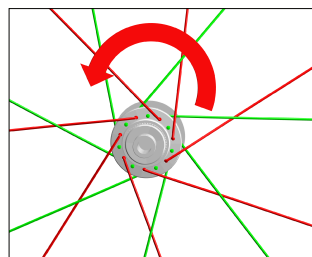

HINTERRAD NICHTANTRIEBSSEITE

**Zugspeiche:** Innenseite des Nabenflansches  
**Druckspeiche:** Außenseite des Nabenflansches

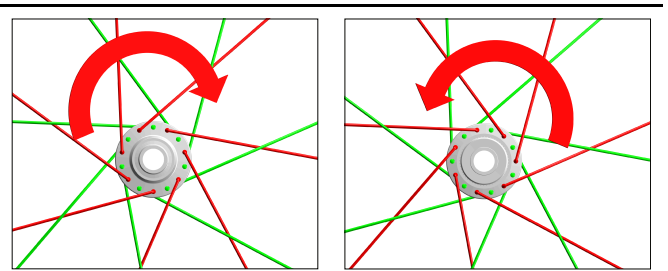

VORDERRAD ANTRIEBSSEITE

**Zugspeiche:** Innenseite des Nabenflansches  
**Druckspeiche:** Außenseite des Nabenflansches

VORDERRAD NICHTANTRIEBSSEITE

**Zugspeiche:** Innenseite des Nabenflansches  
**Druckspeiche:** Außenseite des Nabenflansches

**VENTILLOCHPOSITION**

Das Ventilloch in der Felge sollte sich zwischen zwei parallelen Speichen befinden, um das Aufpumpen des Reifens zu erleichtern.



## POSITION DES NABENLOGOS

Trägt die Nabe ein Logo auf dem Nabenkörper, sollte die Nabe aus ästhetischen Gründen so zur Felge angeordnet werden, dass das Nabenlogo zum Ventilloch an der Felge ausgerichtet ist.

Diese Empfehlung hat keinerlei Auswirkung auf die Funktion des Laufrads. Laufrad-Aufbauten mit anderer Ausrichtung des Nabenlogos werden daher für alle Zwecke als zulässig betrachtet, vorausgesetzt alle anderen Konstruktionsparameter werden eingehalten.

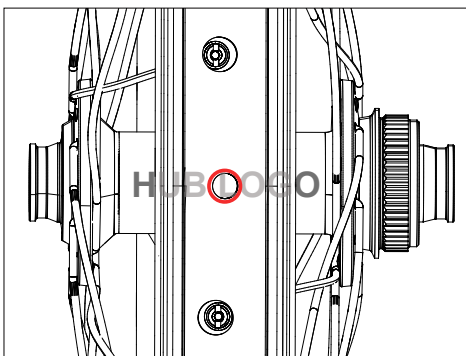

## SPANNEN UND ZENTRIEREN

Um ein Laufrad fachgerecht und sicher zu bauen, bedarf es umfassender technischer Kompetenz und Erfahrung. Benutzer:innen und Techniker:innen, die nicht entsprechend geschult sind oder nicht über die nötige Erfahrung verfügen, sollten kein Laufrad zum späteren Gebrauch selbst bauen.



Dieses Handbuch enthält keine vollständige Anleitung zum kompletten Einspeich- und Spannvorgang bei Laufrädern, sondern nur grundlegende Hinweise zur Fertigstellung von OQUO-Laufrädern mit Angabe der zulässigen Toleranzen. Dementsprechend liefert es lediglich allgemeine Anweisungen zum Einspeichen und Fertigstellen von OQUO-Laufrädern für OQUO-Händler:innen, die eine OQUO-Felge nach Genehmigung durch OQUO ersetzen müssen, und ist nicht als Handbuch für den Laufradbau gedacht.



Eine nicht fachgerecht durchgeführte Laufradkonstruktion kann die strukturelle Integrität und Strapazierfähigkeit des Laufrads kompromittieren und zu einem nicht durch die Gewährleistung abgedeckten Bauteilversagen führen, was schwere oder gar tödliche Verletzungen zur Folge haben kann.

Wenn das Laufrad eingespeicht und die Nippel montiert sind, die Speichen aber noch keine Spannung haben, kannst du das Laufrad gemäß den in diesem Handbuch beschriebenen Toleranzvorgaben zentrieren. Erhöhe die Speichenspannung am Laufrad langsam und gleichmäßig. Wenn du ein paar Speichen angezogen hast, führe folgende Kontrollen durch.

OQUO empfiehlt, die Laufradausrichtung wie folgt zu überprüfen:

- 01** Auf Seitenschlag prüfen
- 02** Auf Höhenschlag prüfen
- 03** Du musst das Laufrad auf beiden Seiten auf Seitenschlag prüfen.

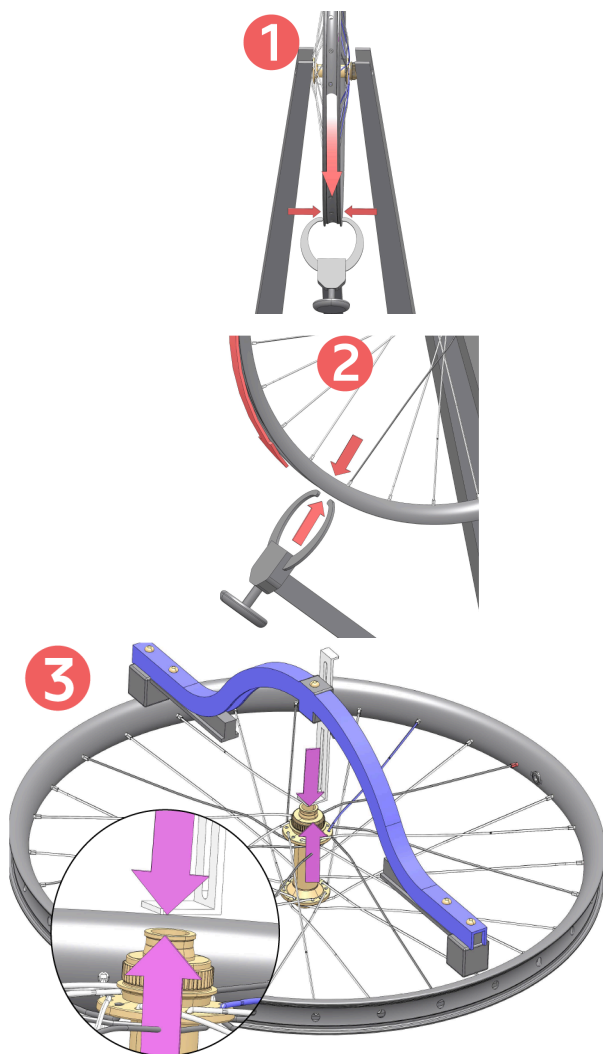

Wenn du mehrere Speichen anziehst, wiederhole diese Überprüfung während des Spannvorgangs so oft wie nötig. Dadurch verhinderst du übermäßige Rundlauffehler, durch die Felgenschäden entstehen können.

#### WARNUNG

Nach jeder Überprüfung auf Seitenschlag, Höhenschlag und Mittigkeit das Laufrad entspannen, damit die Speichen die richtige Position einnehmen und die Überprüfung korrekt durchgeführt werden kann.

Du kannst das Laufrad entspannen, indem du ein Nabenende auf eine feste Unterlage legst und mit den Händen die gegenüberliegenden Seiten der Felge in Richtung Auflageseite der Nabe drückst. Verlagere dabei dein gesamtes Gewicht auf die Hände.

Führe diese Überprüfung auf beiden Seiten des Laufrads durch.

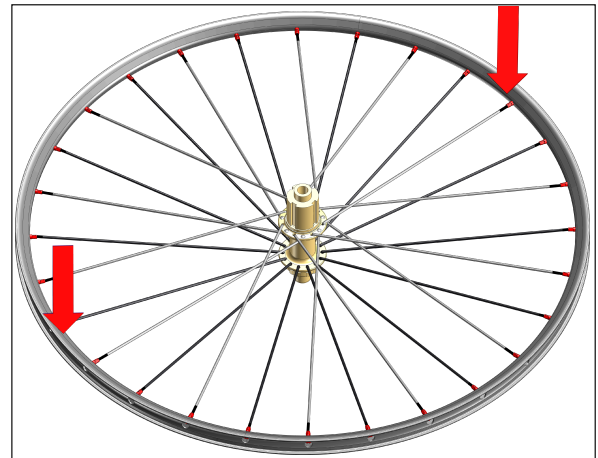

#### PRÜFEN DER SPEICHENSPANNUNG

In der Tabelle mit den technischen Daten in diesem Handbuch (Abschnitt „Speichen“) findest du zu deinem Laufradmodell die Sollspannung für die stärker gespannte Laufradseite. Wenn die Sollspannung auf der vorgegebenen Laufradseite erreicht ist und die Werte für Seitenschlag, Höhenschlag und Mittigkeit innerhalb der Toleranzvorgaben liegen, muss die Speichenspannung auf der weniger stark gespannten Seite gleichmäßig sein.

Verwende stets ein hochwertiges Spannungsmessgerät und überprüfe seine Kalibrierung regelmäßig gemäß den Anweisungen des Herstellers.

Befolge die Herstelleranweisungen für einen ordnungsgemäßen Gebrauch und eine korrekte Auswertung der Spannungswerte unter Berücksichtigung der Speichenspezifikation.

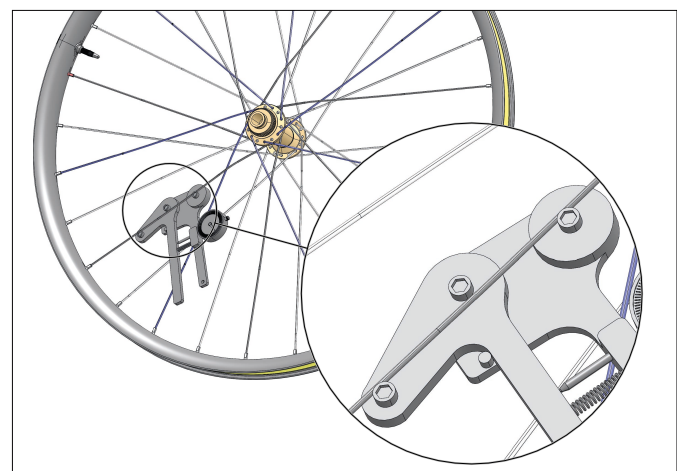

## MONTAGEFETT

Wenn du eines der Laufräder wartest oder einspeichst, empfehlen wir nach dem korrekten Zentrieren und Spannen die Verwendung eines mittelfesten Speichenfixiermittels, das am Speichengewinde möglichst flüssig ist.

## SOLLWERTE UND TOLERANZEN BEIM EINSPEICHEN VON OQUO-LAUFRÄDERN

SOLLSPANNUNG BEIM EINSPEICHEN VON OQUO-LAUFRÄDERN	
TENSION	<p><b>Überprüfe in der Tabelle mit den technischen Daten in diesem Handbuch (Abschnitt „Speichen“) die zu deinem Laufradmodell gehörige Sollspannung für die stärker gespannte Lauftradseite.</b></p> <p>Wenn die Sollspannung auf der vorgegebenen Lauftradseite erreicht ist und die Werte für Seitenschlag, Höhenschlag und Mittigkeit innerhalb der Toleranzvorgaben liegen, muss die Speichenspannung auf der weniger stark gespannten Seite gleichmäßig sein.</p>
	<b>DURCHSCHNITTLICHE SPANNUNGSTOLERANZ DER SPEICHEN AUF DER FESTER GESPANNTEN LAUFRADSEITE</b>
	+/- 5 %

Verwende stets ein hochwertiges Spannungsmessgerät und überprüfe seine Kalibrierung regelmäßig gemäß den Anweisungen des Herstellers. Befolge die Herstelleranweisungen für einen ordnungsgemäßen Gebrauch und eine korrekte Auswertung der Spannungswerte unter Berücksichtigung der Speichenspezifikation.

RUNOUT		SEITENSCHLAG	HÖHENSCHLAG	MITTIGKEIT
	Aluminium	0,4 mm	0,6 mm	0,6 mm
	Carbon	0,3 mm	0,6 mm	0,3 mm

---

## ZUSÄTZLICHE INFORMATIONEN

In den sozialen Medien findest du weitere Informationen über OQUO.

### FACEBOOK

[www.facebook.com/oquo.wheels](http://www.facebook.com/oquo.wheels)

### INSTAGRAM

[www.instagram.com/oquo.wheels/](http://www.instagram.com/oquo.wheels/)

### LINKEDIN

[www.linkedin.com/company/oquowheels/](http://www.linkedin.com/company/oquowheels/)

### YOUTUBE

[www.youtube.com/channel/UCpXzSOB\\_9oLzLzAnnwuaGCg](http://www.youtube.com/channel/UCpXzSOB_9oLzLzAnnwuaGCg)

### HANDBÜCHER

Die aktuellste Version dieses Handbuch sowie Informationen zu anderen OQUO-Produkten kannst du hier herunterladen:

[www.oquowheels.com/en-int/support/manuals](http://www.oquowheels.com/en-int/support/manuals)

### KONTAKT

Bei Fragen zu unseren Produkten besuche bitte diese Seite:

[www.oquowheels.com/en-int/support/contact](http://www.oquowheels.com/en-int/support/contact)

---

**Orbea OQUO SL 2025**  
**Polígono Industrial Kareaga, 2. NAV 49,**  
**Markina-Xemein. 48270. Bizkaia**  
**T. 0034 943 171 950**

Alle Rechte vorbehalten. Sämtliche Änderungen an diesem Dokument sind untersagt.

Dieses technische Produkthandbuch dient nur zu Informationszwecken bezüglich der Montage und Wartung des Produkts und kann als solches Änderungen der technischen Daten und/oder zukünftigen Aktualisierungen der Informationen durch den Hersteller unterliegen. Sein Inhalt hat keinen Werbe- oder Vertragswert in Bezug auf das beschriebene Produkt und kann vom Benutzer nicht als Teil einer Beratung in Bezug auf seine Entscheidung zum Kauf des Produkts betrachtet werden. Daher übernehmen wir keine Verantwortung gegenüber dem Benutzer oder Dritten, falls dieses Handbuch für einen anderen als den beabsichtigten und darin angegebenen Zweck verwendet wird.

Alle Rechte vorbehalten. Sämtliche Änderungen an diesem Dokument sind untersagt. Der Inhalt dieses Handbuch kann sich ohne vorherige Ankündigung ändern.

Die aktuellste Version findest du unter [www.oquowheels.com](http://www.oquowheels.com)

---

## INDICE

<b>Introduzione</b>	<b>199</b>
<b>Tipi di manuali</b>	<b>200</b>
<b>Legenda dei simboli</b>	<b>201</b>
<b>Avvertenze generali per il manuale tecnico</b>	<b>202</b>
<b>Specifiche tecniche e di montaggio per ruote Oquo</b>	<b>203</b>
Tabella gamma ruote OQUO MTB	203
Mountain Performance (MP)	204
MP30 LTD (fino a MY2024)	204
MP30 LTD (da MY2025)	205
MP30 TEAM (fino a MY2024)	206
MP30 TEAM (da MY2025)	207
MP28 PRO (fino a MY2023)	208
MP28 PRO (a partire da MY2024)	209
Mountain Control (MC)	210
MC32 LTD (fino a MY2025)	210
MC32 LTD (da MY2026)	211
MC32 LTD POWER (fino a MY2023)	212
MC32 LTD POWER (a partire da MY2024)	213
MC32 TEAM (fino a MY2024)	214
MC32 TEAM (MY2025)	215
MC32 TEAM (da MY2026)	216
MC32 TEAM RALLON DH MY2026 (OEM)	217
MC32 TEAM POWER (fino a MY2023)	218
MC32 TEAM POWER (MY2024)	219
MC32 TEAM POWER (MY2025)	220
MC32 TEAM POWER (da MY2026)	221
<b>Manutenzione delle ruote Oquo</b>	<b>222</b>
Tabella del programma di manutenzione	222
Strumenti	222
<b>Manutenzione mozzo</b>	<b>228</b>
<b>Ricambi</b>	<b>230</b>
Ricambi mozzi OQUO DT Swiss Inside	230
Mozzi anteriori Oquo DT Swiss Inside	230
Oquo LTD DT Swiss 240 Inside Straight Pull 15x110 24H Centerlock	230

Oquo TEAM DT Swiss 350 Inside Straight Pull 15x110 28H Centerlock/6 bulloni	231
Oquo LTD DT Swiss 350 Inside J-bend 15x110 28H 6 bulloni	232
Mozzi posteriori Oquo DT Swiss Inside	233
Oquo LTD DT Swiss 240 Inside Straight Pull 12x148 28H Centerlock	233
Oquo LTD DT Swiss 350 Inside Straight Pull 12x148 28/32H Centerlock/6 bulloni	234
Oquo LTD DT Swiss Inside 350 DEG J-bend 12x148 32H 6 bulloni	235
Ricambi per mozzi DT Swiss	236
Mozzi anteriori DT Swiss	236
DT Swiss 240 J-bend 15x110 24/28H Centerlock/6-bulloni	236
DT Swiss 350 J-bend 15x110 28H Centerlock/6-bulloni	237
DT Swiss 350 J-bend 20x110 28H 6-bulloni	238
DT Swiss 370 J-bend 15x110 28H 6 bulloni	239
DT Swiss 350 Hybrid J-bend 15x110 32H 6-bulloni (fino a MY2023)	240
DT Swiss 350 Hybrid J-bend 15x110 28H 6-bulloni (da MY2024)	241
Mozzi posteriori DT Swiss	242
DT Swiss 240 J-bend 12x148 28H Centerlock	242
DT Swiss 350 J-bend 12x148 28/32H Centerlock/6 bulloni	243
DT Swiss 370 J-bend 12x148 28H 6 bulloni	244
DT Swiss 350 Hybrid J-bend 12x148 32H 6-bulloni (fino a MY2023)	245
DT Swiss 350 Hybrid J-bend 12x148 32H 6-bulloni (da MY2024)	246
Raggi. Kit raggi ruota Oquo	247
Valvole tubeless Oquo	251
<b>Assemblaggio ruote Oquo</b>	<b>253</b>
<b>Informazioni aggiuntive</b>	<b>261</b>

---

## INTRODUZIONE

Le informazioni contenute nel presente manuale sono principalmente destinate ai distributori OQUO e agli utenti con esperienza nella manutenzione delle ruote.

Se un utente non dispone delle conoscenze e competenze per eseguire le procedure di manutenzione descritte nel presente manuale tecnico o per montare i ricambi elencati, le riparazioni e la manutenzione delle ruote dovranno essere affidate a un rivenditore OQUO.

Le informazioni di contatto dei distributori sono disponibili sul nostro sito web.

[www.oquowheels.com](http://www.oquowheels.com)

### AVVISO

---

I danni causati da operazioni di manutenzione o riparazione inadeguate non sono coperti dalle condizioni di garanzia.



Interventi errati di riparazione, manutenzione o montaggio dei componenti possono avere effetti negativi su integrità e funzionamento delle ruote, e causare incidenti con lesioni gravi o letali.

---

## TIPI DI MANUALI

### MANUALE TECNICO

Il presente manuale contiene specifiche, procedure di manutenzione e ricambi originali per i prodotti OQUO ed è destinato specificamente a distributori specializzati o utenti con le necessarie competenze.

Le procedure di manutenzione per i componenti di terze parti montati sulle nostre ruote sono incluse mediante i link alla documentazione dei rispettivi produttori.

Le procedure, le specifiche e i ricambi descritti nel presente manuale sono soggetti alle variazioni delle specifiche relative ai nostri prodotti.

L'ultima versione del presente manuale tecnico è disponibile sul sito web OQUO.

### MANUALE D'USO

Per accedere al manuale utente delle nostre ruote, che elenca informazioni sul corretto uso delle ruote e avvertenze per uso, trasporto, stoccaggio, montaggio, ecc., consultare il manuale d'uso sul nostro sito web.

È possibile accedere alla documentazione del prodotto, come anche alle relative informazioni sulla garanzia e ai programmi di manutenzione sul nostro sito web:

<https://www.oquowheels.com/it-it/assistenza/manuali>

---

## LEGENDA DEI SIMBOLI

Nel presente manuale tecnico sono utilizzati simboli che indicano istruzioni, avvertenze e informazioni importanti per l'uso, la manutenzione e il montaggio. Prestare attenzione a tali simboli, per evitare situazioni pericolose e garantire un uso e un montaggio corretti di tutti i componenti.

Il significato dei simboli viene illustrato qui di seguito. Nel presente manuale, il simbolo potrà apparire accompagnato unicamente dall'istruzione pertinente per il componente descritto. Leggere attentamente le seguenti informazioni, assicurandosi di comprenderne il significato.

### ISTRUZIONI DI SICUREZZA



---

**PERICOLO:** situazione pericolosa che, se non evitata, causerà lesioni gravi o letali



---

**AVVERTENZA:** situazione pericolosa che, se non evitata, potrebbe causare lesioni gravi o letali.



---

**ATTENZIONE:** situazione pericolosa che, se non evitata, potrebbe causare lesioni da leggere a moderate.



---

**AVVISO**  
Situazione non connessa a lesioni fisiche. Informazioni importanti.

I simboli PERICOLO e AVVERTENZA implicano sempre un rischio di incidente se non si adottano le misure necessarie per evitare la situazione descritta. Un incidente in bicicletta può comportare il rischio di lesioni gravi o anche letali. Nel presente manuale, il rischio di morte potrebbe pertanto non essere sempre menzionato quando compaiono questi simboli, dato che tale rischio viene illustrato in questo punto.

### STRUMENTI

Utilizzare sempre i prodotti o gli strumenti adeguati per una specifica operazione di manutenzione o riparazione. Strumenti non adatti o soggetti a scarsa manutenzione, oppure l'utilizzo di prodotti generici, possono causare danni ai componenti non coperti dalle condizioni di garanzia.

Gli strumenti da usare sono specificati nel presente manuale, oppure viene fornito un riferimento ai manuali di manutenzione del produttore dei componenti usati nella nostra ruota, nei quali sono descritti gli strumenti appropriati.

---

## AVVERTENZE GENERALI PER IL MANUALE TECNICO

- Per le istruzioni di montaggio e manutenzione e le avvertenze per l'uso di componenti di terze parti presenti nelle nostre ruote, quali dischi dei freni, cassette pignoni, pneumatici, ecc., consultare la documentazione del produttore dei rispettivi componenti.
- Durante l'uso o la regolazione, tenere lontano dai dischi dei freni o dai raggi qualsiasi parte del corpo e/o degli indumenti, per evitare lesioni gravi e ferite.
- Come regola generale, pulire tutti i componenti durante la manutenzione o ispezione, prima di rimontarli.
- Mantenere ruote e relativi componenti puliti e privi di corpi estranei, per garantirne il funzionamento adeguato e per essere in grado di valutarne le condizioni.
- Utilizzare sempre un panno morbido e prodotti specifici per la pulizia per pulire ruote e componenti.
- Non usare getti d'acqua a pressione o sostanze chimiche aggressive per pulire ruote e relativi componenti. I getti d'acqua a pressione possono diluire i lubrificanti, riducendo così la vita utile dei lubrificanti e/o causando danni non coperti dalle condizioni di garanzia.

### RICAMBI

Utilizzare esclusivamente ricambi OQUO originali o quelli indicati nel presente manuale oppure nella documentazione del produttore dei componenti in oggetto.

#### AVVISO

---

L'impiego di ricambi non originali può dare luogo a danni dei componenti non coperti dalle condizioni di garanzia.



---

L'uso di ricambi non originali può provocare guasti ai componenti, che possono causare incidenti e lesioni gravi.

## SPECIFICHE TECNICHE E DI MONTAGGIO PER RUOTE OQUO

Le tabelle seguenti elencano le specifiche dei componenti e di montaggio per tutti i modelli MTB OQUO

Nel manuale vengono indicati i riferimenti a tali tabelle, ove rilevante nelle specifiche sezioni. Consultare le tabelle per trovare i dati necessari.

**TABELLA GAMMA RUOTE OQUO MTB**

	FAMIGLIA	MODELLO	CATEGORIA
MTB	MOUNTAIN PERFORMANCE (MP)	MP30LTD	XC, MARATHON, TRAIL
		MP30TEAM	
		MP28PRO	
	MOUNTAIN CONTROL (MC)	MC32LTD	TRAIL, ENDURO, GRAVITY
		MC32LTD POWER	E-ENDURO, GRAVITY
		MC32TEAM	TRAIL, ENDURO, GRAVITY
		MC32TEAM POWER	E-ENDURO, GRAVITY

## MOUNTAIN PERFORMANCE (MP)

## MP30 LTD (fino a MY2024)

	MODELLO	MATERIALE	TAGLIA	TIPOLOGIA CERCHIO	TIPOLOGIA FRENO	TUBELESS	LARGHEZZA INTERNA	OFFSET	FORI DIREZIONALI PER I RAGGI	FORATURA RAGGI	ERD	ETRTO	GIUNTO	LARGHEZZA NASTRO TUBELESS	VALVOLA	PNEUMATICI COMPATIBILI	PRESSIONE MASSIMA	SEZIONE	
CERCHI	CERCHIO ANTERIORE (28H)	MP10-F-29-28H	Carbonio	29"	Copertoncino Hookless	Disco	Sì	30 mm	2 mm	Sì	28	611 mm	622x30TSS	—	30 mm	44 mm	2,05"-2,8"	**	
	CERCHIO ANTERIORE (24H)	MP11-F-29-24H	Carbonio	29"	Copertoncino Hookless	Disco	Sì	30 mm	2 mm	Sì	24	611 mm	622x30TSS	—	30 mm	44 mm	2,05"-2,8"	**	
	CERCHIO POSTERIORE	MP10-R-29-28H	Carbonio	29"	Copertoncino Hookless	Disco	Sì	30 mm	-2 mm	Sì	28	607,6 mm	622x30TSS	—	30 mm	44 mm	2,05"-2,8"	**	

	No. RAGGI	MODELLO	RAGGIATURA DRIVE SIDE (dx)	RAGGIATURA NON-DRIVE SIDE (sx)	LUNGHEZZA RAGGI DRIVE SIDE (dx)	LUNGHEZZA RAGGI NON-DRIVE SIDE (sx)	TENSIONE ASSEMBLAGGIO DRIVE SIDE (dx)	TENSIONE ASSEMBLAGGIO LATO DISCO	RAGGIO "LEADING" DRIVE SIDE (dx)	RAGGIO "TRAILING" DRIVE SIDE (dx)	RAGGIO "LEADING" NON-DRIVE SIDE (sx)	RAGGIO "TRAILING" NON-DRIVE SIDE (sx)	
RAGGI	ANTERIORE (28H)	28	Sapim CX-Ray TCS Aero 14G (2 mm) J-Bend	3 incroci	3 incroci	299 mm	297 mm	—	1200 N	Esterno	Interno	Esterno	Interno
	ANTERIORE (24H)	24	Sapim CX-Ray TCS Aero 14G (2 mm) J-Bend	3 incroci	3 incroci	293 mm	291 mm	—	1200 N	Esterno	Interno	Esterno	Interno
	POSTERIORE	28	Sapim CX-Ray TCS Aero 14G (2 mm) J-Bend	3 incroci	3 incroci	295 mm	296 mm	1300 N	—	Interno	Esterno	Esterno	Interno

	MODELLO	SPAZIATURA (VECCHIO)	ASSE	TIPO DISCO	RAGGI	CORPETTO RUOTA LIBERA	MECCANISMO RUOTA LIBERA
MOZZI	MOZZO ANTERIORE (28H)	DT SWISS 240 Classic CL	Boost 110 mm	Asse passante 15 mm	Centre Lock	28 J-Bend	—
	MOZZO ANTERIORE (24H)	DT SWISS 240 Classic CL	Boost 110 mm	Asse passante 15 mm	Centre Lock	24 J-Bend	—
	MOZZO POSTERIORE	DT SWISS 240 Classic CL	Boost 148 mm	Asse passante 12 mm	Centre Lock	28 J-Bend	Sram XD o Shimano Microspline Ratchet EXP 36

	MODELLO	MISURE	RONDELLE NIPPLI	
NIPPLI	ANTERIORE (28H)	Sapim Alloy Double Square	2x18 mm (14G)	No
	ANTERIORE (24H)	Sapim Alloy Double Square	2x18 mm (14G)	No
	POSTERIORE	Sapim Alloy Double Square	2x18 mm (14G)	No

	RUOTA	PESO
PESO RUOTA	ANTERIORE (28H)	625 g +/-5%
	ANTERIORE (24H)	591 g +/-5%
	POSTERIORE	730 g +/-5%

USO.
<p><b>Condizione ASTM 3</b> (Vd. Manuale d'uso)</p> <p>Peso max del sistema (bici + ciclista + equipaggiamento) = <b>110 kg.</b></p>

\*\* Per la pressione massima degli pneumatici, consultare il manuale d'uso o la decalcomania presente sulla ruota.

Fare clic o tap sul modello di mozzo o raggio per accedere alle informazioni sui ricambi

## MOUNTAIN PERFORMANCE (MP)

## MP30 LTD (da MY2025)

	MODELLO	MATERIALE	TAGLIA	TIPOLOGIA CERCHIO	TIPOLOGIA FRENO	TUBELESS	LARGHEZZA INTERNA	OFFSET	FORI DIREZIONALI PER I RAGGI	FORATURA RAGGI	ERD	ETRTO	GIUNTO	LARGHEZZA NASTRO TUBELESS	VALVOLA	PNEUMATICI COMPATIBILI	PRESSIONE MASSIMA	SEZIONE	
CERCHI	CERCHIO ANTERIORE	MP11-F-29-24H	Carbonio	29"	Copertoncino Hookless	Disco	Sì	30 mm	2 mm	Sì	24	601 mm	622x30TSS	—	30 mm	44 mm	2,05"-2,8"	**	
	CERCHIO POSTERIORE	MP10-R-29-28H	Carbonio	29"	Copertoncino Hookless	Disco	Sì	30 mm	-2 mm	Sì	28	599 mm	622x30TSS	—	30 mm	44 mm	2,05"-2,8"	**	

	No. RAGGI	MODELLO	RAGGIATURA DRIVE SIDE (dx)	RAGGIATURA NON-DRIVE SIDE (sx)	LUNGHEZZA RAGGI DRIVE SIDE (dx)	LUNGHEZZA RAGGI NON-DRIVE SIDE (sx)	TENSIONE ASSEMBLAGGIO DRIVE SIDE (dx)	TENSIONE ASSEMBLAGGIO LATO DISCO	
RAGGI	ANTERIORE (24H)	24	DT aerolite T-shape SP* 2,0-(0,9x2,2)-2 mm	2 incroci	2 incroci	301 mm	301 mm	—	1200 N
	POSTERIORE	28	DT aerolite T-shape SP* 2,0-(0,9x2,2)-2 mm	3 incroci	3 incroci	304 mm	304 mm	1300 N	—

MOZZI	MODELLO	SPAZIATURA (VECCHIO)	ASSE	TIPO DISCO	RAGGI	CORPETTO RUOTA LIBERA	MECCANISMO RUOTA LIBERA	NIPPLI	MODELLO	MISURE	RONDELLE NIPPLI	PESO RUOTA	RUOTA	PESO	USO.
	MOZZO ANTERIORE	OQUO LTD DT 240 INSIDE	Boost 110 mm	Asse passante 15 mm	Centre Lock	24 SP*	—		—	ANTERIORE	DT Alloy Double Square		2x15 mm (FG 2,3)	No	
MOZZO POSTERIORE	OQUO LTD DT 240 INSIDE	Boost 148 mm	Asse passante 12 mm	Centre Lock	28 SP*	Sram XD o SP Shimano Microspline	DT Swiss Ratchet EXP 10° / 36	POSTERIORE	DT Alloy Double Square	2x15 mm (FG 2,3)	No	POSTERIORE	740 g +/-5%		

\* SP: Straightpull

\*\* Per la pressione massima degli pneumatici, consultare il manuale d'uso o la decalcomania presente sulla ruota.

Fare clic o tap sul modello di mozzo o raggio per accedere alle informazioni sui ricambi

## MOUNTAIN PERFORMANCE (MP)

## MP30 TEAM (fino a MY2024)

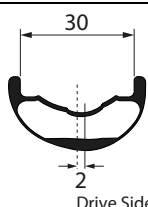
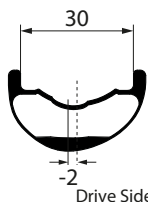
	MODELLO	MATERIALE	TAGLIA	TIPOLOGIA CERCHIO	TIPOLOGIA FRENO	TUBELESS	LARGHEZZA INTERNA	OFFSET	FORI DIREZIONALI PER I RAGGI	FORATURA RAGGI	ERD	ETRTO	GIUNTO	LARGHEZZA NASTRO TUBELESS	VALVOLA	PNEUMATICI COMPATIBILI	PRESSIONE MASSIMA	SEZIONE	
CERCHI	CERCHIO ANTERIORE	MP10-F-29-28H	Carbonio	29"	Copertoncino Hookless	Disco	Sì	30 mm	2 mm	Sì	28	611 mm	622x30TSS	—	30 mm	44 mm	2,05"-2,8"	**	
	CERCHIO POSTERIORE	MP10-R-29-28H	Carbonio	29"	Copertoncino Hookless	Disco	Sì	30 mm	-2 mm	Sì	28	607,6 mm	622x30TSS	—	30 mm	44 mm	2,05"-2,8"	**	

	No. RAGGI	MODELLO	RAGGIATURA DRIVE SIDE (dx)	RAGGIATURA NON-DRIVE SIDE (sx)	LUNGHEZZA RAGGI DRIVE SIDE (dx)	LUNGHEZZA RAGGI NON-DRIVE SIDE (sx)	TENSIONE ASSEMBLAGGIO DRIVE SIDE (dx)	TENSIONE ASSEMBLAGGIO LATO DISCO	RAGGIO "LEADING" DRIVE SIDE (dx)	RAGGIO "TRAILING" DRIVE SIDE (dx)	RAGGIO "LEADING" NON-DRIVE SIDE (sx)	RAGGIO "TRAILING" NON-DRIVE SIDE (sx)
ANTERIORE	28	Sapim D-Sprint Rinforzato 14G (2 mm) J-Bend	3 incroci	3 incroci	298 mm	297 mm	—	1200 N	Esterno	Interno	Esterno	Interno
POSTERIORE	28	Sapim D-Sprint Rinforzato 14G (2 mm) J-Bend	3 incroci	3 incroci	294 mm	295 mm	1300 N	—	Interno	Esterno	Esterno	Interno

MOZZI	MODELLO	SPAZIATURA (VECCHIO)	ASSE	TIPO DISCO	RAGGI	CORPETTO RUOTA LIBERA	MECCANISMO RUOTA LIBERA	NIPPLI	MODELLO	MISURE	RONDELLE NIPPLI	PESO RUOTA	RUOTA	PESO	UTILIZZO
	MOZZO ANTERIORE	DT SWISS 350 Classic CL	Boost 110 mm	Asse passante 15 mm	Centre Lock	28 J-Bend	—		—	ANTERIORE	Sapim Brass Polyax		2x14 mm (14G)	No	
MOZZO POSTERIORE	DT SWISS 350 Classic CL	Boost 148 mm	Asse passante 12 mm	Centre Lock	28 J-Bend	Sram XD o Shimano Microspline	Ratchet 36	POSTERIORE	Sapim Brass Polyax	2x14 mm (14G)	No	POSTERIORE	830 g +/-5%		

\*\* Per la pressione massima degli pneumatici, consultare il manuale d'uso o la decalcomania presente sulla ruota.

Fare clic o tap sul modello di mozzo o raggio per accedere alle informazioni sui ricambi

**Condizione ASTM 3**  
(Vd. Manuale d'uso)  
Peso max del sistema  
(bici + ciclista +  
equipaggiamento) =  
**110 kg.**

## MOUNTAIN PERFORMANCE (MP)

## MP30 TEAM (da MY2025)

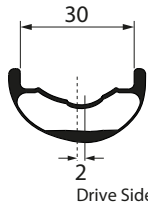
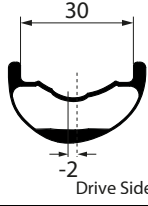
	MODELLO	MATERIALE	TAGLIA	TIPOLOGIA CERCHIO	TIPOLOGIA FRENO	TUBELESS	LARGHEZZA INTERNA	OFFSET	FORI DIREZIONALI PER I RAGGI	FORATURA RAGGI	ERD	ETRTO	GIUNTO	LARGHEZZA NASTRO TUBELESS	VALVOLA	PNEUMATICI COMPATIBILI	PRESSIONE MASSIMA	SEZIONE	
CERCHI	CERCHIO ANTERIORE	MP10-F-29-28H	Carbonio	29"	Copertoncino Hookless	Disco	Sì	30 mm	2 mm	Sì	28	611 mm	622x30TSS	—	30 mm	44 mm	2,05"-2,8"	**	
	CERCHIO POSTERIORE	MP10-R-29-28H	Carbonio	29"	Copertoncino Hookless	Disco	Sì	30 mm	-2 mm	Sì	28	607,6 mm	622x30TSS	—	30 mm	44 mm	2,05"-2,8"	**	

	No. RAGGI	MODELLO	RAGGIATURA DRIVE SIDE (dx)	RAGGIATURA NON-DRIVE SIDE (sx)	LUNGHEZZA RAGGI DRIVE SIDE (dx)	LUNGHEZZA RAGGI NON-DRIVE SIDE (sx)	TENSIONE ASSEMBLAGGIO DRIVE SIDE (dx)	TENSIONE ASSEMBLAGGIO LATO DISCO	
RAGGI	ANTERIORE	28	Sapim Sprint SP* Rinforzati 2,0/1,7/2,0	3 incroci	3 incroci	305 mm	305 mm	—	1200 N
	POSTERIORE	28	Sapim Sprint SP* Rinforzati 2,0/1,7/2,0	3 incroci	3 incroci	303 mm	303 mm	1300 N	—

MOZZI	MODELLO	SPAZIATURA (VECCIO)	ASSE	TIPO DISCO	RAGGI	CORPETTO RUOTA LIBERA	MECCANISMO RUOTA LIBERA	NIPPLI	MODELLO	MISURE	RONDELLE NIPPLI	PESO RUOTA	RUOTA	PESO	UTILIZZO
	MOZZO ANTERIORE	OQUO TEAM DT 350 INSIDE	Boost 110 mm	Asse passante 15 mm	Centre Lock	28 SP*	—		—	ANTERIORE	Sapim Alloy Double Square		2x18 mm (14G)	No	
MOZZO POSTERIORE	OQUO TEAM DT 350 INSIDE	Boost 148 mm	Asse passante 12 mm	Centre Lock	28 SP*	Sram XD o Shimano Microspline	DT Swiss Ratchet 10°/36	POSTERIORE	Sapim Alloy Double Square	2x18 mm (14G)	No	POSTERIORE	810 g +/-5%		

\* SP: Straightpull

\*\* Per la pressione massima degli pneumatici, consultare il manuale d'uso o la decalcomania presente sulla ruota.

Fare clic o tap sul modello di mozzo o raggio per accedere alle informazioni sui ricambi

**Condizione ASTM 4**  
(Vd. Manuale d'uso)

Peso max del sistema  
(bici + ciclista +  
equipaggiamento) =  
**110 kg.**

## MOUNTAIN PERFORMANCE (MP)

## MP28 PRO (fino a MY2023)

	MODELLO	MATERIALE	TAGLIA	TIPOLOGIA CERCHIO	TIPOLOGIA FRENO	TUBELESS	LARGHEZZA INTERNA	OFFSET	FORI DIREZIONALI PER I RAGGI	FORATURA RAGGI	ERD	ETRTO	GIUNTO	LARGHEZZA NASTRO TUBELESS	VALVOLA	PNEUMATICI COMPATIBILI	PRESSIONE MASSIMA	SEZIONE	
CERCHI	ANTERIORE/POSTERIORE	MP30-B-29-28H	Alluminio AL6061	29"	Copertoncino Hookless	Disco	Sì	28 mm	2 mm	Sì	28	600 mm	622x28TSS	Sleeved (giuntato)	28 mm	40 mm	2"-2,55"	**	

	No. RAGGI	MODELLO	RAGGIATURA DRIVE SIDE (dx)	RAGGIATURA NON-DRIVE SIDE (sx)	LUNGHEZZA RAGGI DRIVE SIDE (dx)	LUNGHEZZA RAGGI NON-DRIVE SIDE (sx)	TENSIONE ASSEMBLAGGIO DRIVE SIDE (dx)	TENSIONE ASSEMBLAGGIO LATO DISCO	RAGGIO "LEADING" DRIVE SIDE (dx)	RAGGIO "TRAILING" DRIVE SIDE (dx)	RAGGIO "LEADING" NON-DRIVE SIDE (sx)	RAGGIO "TRAILING" NON-DRIVE SIDE (sx)	
RAGGI	ANTERIORE	28	Sapim Race Rinforzato 14G (2 mm) J-Bend	3 incroci	3 incroci	298 mm	297 mm	—	1200 N	Esterno	Interno	Esterno	Interno
	POSTERIORE	28	Sapim Race Rinforzato 14G (2 mm) J-Bend	3 incroci	3 incroci	296 mm	297 mm	1200 N	—	Interno	Esterno	Esterno	Interno

	MODELLO	SPAZIATURA (VECCIO)	ASSE	TIPO DISCO	RAGGI	CORPETTO RUOTA LIBERA	MECCANISMO RUOTA LIBERA		MODELLO	MISURE	RONDELLE NIPPLI		RUOTA	PESO			
MOZZI	MOZZO ANTERIORE	DT SWISS 350 Classic CL	Boost 110 mm	Asse passante 15 mm	Centre Lock	28 J-Bend	—	—	NIPPLI	ANTERIORE	Sapim Brass Polyax	2x14 mm (14G)	No	PESO RUOTA	ANTERIORE	850 g +/-5%	UTILIZZO  Condizione ASTM 4 (Vd. Manuale d'uso) Peso max del sistema (bici + ciclista + equipaggiamento) = 110 kg.
	MOZZO POSTERIORE	DT SWISS 350 Classic CL	Boost 148 mm	Asse passante 12 mm	Centre Lock	28 J-Bend	Sram XD Shimano Microspline Shimano HG	Ratchet 36		POSTERIORE	Sapim Brass Polyax	2x14 mm (14G)	No		POSTERIORE	955 g +/-5%	

\*\* Per la pressione massima degli pneumatici, consultare il manuale d'uso o la decalcomania presente sulla ruota.

Fare clic o tap sul modello di mozzo o raggio per accedere alle informazioni sui ricambi

## MOUNTAIN PERFORMANCE (MP)

## MP28 PRO (a partire da MY2024)

	MODELLO	MATERIALE	TAGLIA	TIPOLOGIA CERCHIO	TIPOLOGIA FRENO	TUBELESS	LARGHEZZA INTERNA	OFFSET	FORI DIREZIONALI PER I RAGGI	FORATURA RAGGI	ERD	ETRTO	GIUNTO	LARGHEZZA NASTRO TUBELESS	VALVOLA	PNEUMATICI COMPATIBILI	PRESSIONE MASSIMA	SEZIONE	
CERCHI	ANTERIORE/POSTERIORE	MP31-B-29-28H	Alluminio AL6061	29"	Copertoncino Hookless	Disco	Si	28 mm	2 mm	Si	28	600 mm	622x28TSS	Sleeved (giuntato)	28 mm	40 mm	2"-2,55"	**	

	No. RAGGI	MODELLO	RAGGIATURA DRIVE SIDE (dx)	RAGGIATURA NON-DRIVE SIDE (sx)	LUNGHEZZA RAGGI DRIVE SIDE (dx)	LUNGHEZZA RAGGI NON-DRIVE SIDE (sx)	TENSIONE ASSEMBLAGGIO DRIVE SIDE (dx)	TENSIONE ASSEMBLAGGIO LATO DISCO	RAGGIO "LEADING" DRIVE SIDE (dx)	RAGGIO "TRAILING" DRIVE SIDE (dx)	RAGGIO "LEADING" NON-DRIVE SIDE (sx)	RAGGIO "TRAILING" NON-DRIVE SIDE (sx)	
RAGGI	ANTERIORE	28	Sapim Race Rinforzato 14G (2 mm) J-Bend	3 incroci	3 incroci	297 mm	296 mm	—	1200 N	Esterno	Interno	Esterno	Interno
	POSTERIORE	28	Sapim Race Rinforzato 14G (2 mm) J-Bend	3 incroci	3 incroci	296 mm	296 mm	1200 N	—	Interno	Esterno	Esterno	Interno

	MODELLO	SPAZIATURA (VECCHIO)	ASSE	TIPO DISCO	RAGGI	CORPETTO RUOTA LIBERA	MECCANISMO RUOTA LIBERA		MODELLO	MISURE	RONDELLE NIPPLI		RUOTA	PESO			
MOZZI	MOZZO ANTERIORE	DT SWISS 370 Classic IS	Boost 110 mm	Asse passante 15 mm	6 bulloni	28 J-Bend	—	—	NIPPLI	ANTERIORE	Sapim Brass Polyax	2x14 mm (14G)	No	PESO RUOTA	ANTERIORE	890 g +/-5%	UTILIZZO Condizione ASTM 4 (Vd. Manuale d'uso) Peso max del sistema (bici + ciclista + equipaggiamento) = <b>110 kg.</b>
	MOZZO POSTERIORE	DT SWISS 370 Classic IS	Boost 110 mm	Asse passante 15 mm	6 bulloni	28 J-Bend	Sram XD Shimano Microspline	Ratchet LN 18		POSTERIORE	Sapim Brass Polyax	2x14 mm (14G)	No		POSTERIORE	1040 g +/-5%	

\*\* Per la pressione massima degli pneumatici, consultare il manuale d'uso o la decalcomania presente sulla ruota.

Fare clic o tap sul modello di mozzo o raggio per accedere alle informazioni sui ricambi

## MOUNTAIN CONTROL (MC)

## MC32 LTD (fino a MY2025)

	MODELLO	MATERIALE	TAGLIA	TIPOLOGIA CERCHIO	TIPOLOGIA FRENO	TUBELESS	LARGHEZZA INTERNA	OFFSET	FORI DIREZIONALI PER I RAGGI	FORATURA RAGGI	ERD	ETRTO	GIUNTO	LARGHEZZA NASTRO TUBELESS	VALVOLA	PNEUMATICI COMPATIBILI	PRESSIONE MASSIMA	SEZIONE	
CERCHI	CERCHIO ANTERIORE	MC10-F-29-28H	Carbonio	29"	Copertoncino Hookless	Disco	Sì	32 mm	2 mm	Sì	28	604,26 mm	622x32TSS	—	32 mm	44 mm	2,4"-2,8"	**	
	CERCHIO POSTERIORE	MC10-R-29-32H	Carbonio	29"	Copertoncino Hookless	Disco	Sì	30 mm	-2 mm	Sì	32	599,86 mm	622x30TSS	—	30 mm	44 mm 57 mm su Wild con magnete nella valvola	2,05"-2,8"	**	

	No. RAGGI	MODELLO	RAGGIATURA DRIVE SIDE (dx)	RAGGIATURA NON-DRIVE SIDE (sx)	LUNGHEZZA RAGGI DRIVE SIDE (dx)	LUNGHEZZA RAGGI NON-DRIVE SIDE (sx)	TENSIONE ASSEMBLAGGIO DRIVE SIDE (dx)	TENSIONE ASSEMBLAGGIO LATO DISCO	RAGGIO "LEADING" DRIVE SIDE (dx)	RAGGIO "TRAILING" DRIVE SIDE (dx)	RAGGIO "LEADING" NON-DRIVE SIDE (sx)	RAGGIO "TRAILING" NON-DRIVE SIDE (sx)	
RAGGI	ANTERIORE	28	Sapim D-Sprint Rinforzato. 14G (2 mm) J-Bend	3 incroci	3 incroci	301 mm	298 mm	—	1200 N	Esterno	Interno	Esterno	Interno
	POSTERIORE	32	Sapim D-Sprint Rinforzato. 14G (2 mm) J-Bend	3 incroci	3 incroci	292 mm	292 mm	1300 N	—	Interno	Esterno	Esterno	Interno

MOZZI	MODELLO	SPAZIATURA (VECCHIO)	ASSE	TIPO DISCO	RAGGI	CORPETTO RUOTA LIBERA	MECCANISMO RUOTA LIBERA	NIPPLI	MODELLO	MISURE	RONDELLE NIPPLI	PESO RUOTA	RUOTA	PESO	UTILIZZO
	MOZZO ANTERIORE	DT SWISS 350 Classic IS	Boost 110 mm	Asse passante 15 mm	6 bulloni	28 J-Bend	—		—	ANTERIORE	Sapim Brass Polyax		2x14 mm (14G)	No	
MOZZO POSTERIORE	DT SWISS 350 Classic IS	Boost 148 mm	Asse passante 12 mm	6 bulloni	32J-Bend	Sram XD Shimano MS	Ratchet 36	POSTERIORE	Sapim Brass Polyax	2x14 mm (14G)	No	POSTERIORE	1042 g +/-5%		

\*\* Per la pressione massima degli pneumatici, consultare il manuale d'uso o la decalcomania presente sulla ruota.

Fare clic o tap sul modello di mozzo o raggio per accedere alle informazioni sui ricambi

Condizione ASTM 5  
(Vd. Manuale d'uso)

Peso max del sistema  
(bici + ciclista +  
equipaggiamento) =  
**135 kg.**

## MOUNTAIN CONTROL (MC)

## MC32 LTD (da MY2026)

	MODELLO	MATERIALE	TAGLIA	TIPOLOGIA CERCHIO	TIPOLOGIA FRENO	TUBELESS	LARGHEZZA INTERNA	OFFSET	FORI DIREZIONALI PER I RAGGI	FORATURA RAGGI	ERD	ETRTO	GIUNTO	LARGHEZZA NASTRO TUBELESS	VALVOLA	PNEUMATICI COMPATIBILI	PRESSIONE MASSIMA	SEZIONE	
CERCHI	CERCHIO ANTERIORE	MC10-F-29-28H	Carbonio	29"	Copertoncino Hookless	Disco	Sì	32 mm	2 mm	Sì	28	604,26 mm	622x32TSS	—	32 mm	44 mm	2,4"-2,8"	**	 32 2 Drive Side
	CERCHIO POSTERIORE	MC10-R-29-32H	Carbonio	29"	Copertoncino Hookless	Disco	Sì	30 mm	-2 mm	Sì	32	599,86 mm	622x30TSS	—	30 mm	44 mm 57 mm su Wild con magnete nella valvola	2,05"-2,8"	**	 30 -2 Drive Side

	No. RAGGI	MODELLO	RAGGIATURA DRIVE SIDE (dx)	RAGGIATURA NON-DRIVE SIDE (sx)	LUNGHEZZA RAGGI DRIVE SIDE (dx)	LUNGHEZZA RAGGI NON-DRIVE SIDE (sx)	TENSIONE ASSEMBLAGGIO DRIVE SIDE (dx)	TENSIONE ASSEMBLAGGIO LATO DISCO	RAGGIO "LEADING" DRIVE SIDE (dx)	RAGGIO "TRAILING" DRIVE SIDE (dx)	RAGGIO "LEADING" NON-DRIVE SIDE (sx)	RAGGIO "TRAILING" NON-DRIVE SIDE (sx)
ANTERIORE	28	Sapim Sprint Rinf. 14G (2 mm) J-Bend	3 incroci	3 incroci	299 mm	299 mm	—	1200 N	Esterno	Interno	Esterno	Interno
POSTERIORE	32	Sapim Race Rinf. 14G (2 mm) J-Bend	3 incroci	3 incroci	291 mm	291 mm	1300 N	—	Interno	Esterno	Esterno	Interno

MOZZI	MODELLO	SPAZIATURA (VECCIO)	ASSE	TIPO DISCO	RAGGI	CORPETTO RUOTA LIBERA	MECCANISMO RUOTA LIBERA	NIPPLI	MODELLO	MISURE	RONDELLE NIPPLI	PESO RUOTA	RUOTA	PESO	UTILIZZO
	MOZZO ANTERIORE	OQUO LTD DT 350 INSIDE	Boost 110 mm	Asse passante 15 mm	6 bulloni	28 J-Bend	—		—	ANTERIORE	Sapim Brass Polyax		2x14 mm (14G)	No	
MOZZO POSTERIORE	OQUO LTD DT 350 DEG INSIDE	Boost 148 mm	Asse passante 12 mm	6 bulloni	32 J-Bend	Sram XD Shimano MS	Ratchet DEG 72	POSTERIORE	Sapim Brass Polyax	2x14 mm (14G)	No	POSTERIORE	1042 g +/-5%		

\*\* Per la pressione massima degli pneumatici, consultare il manuale d'uso o la decalcomania presente sulla ruota.

Fare clic o tap sul modello di mozzo o raggio per accedere alle informazioni sui ricambi

Condizione ASTM 5  
(Vd. Manuale d'uso)

Peso max del sistema  
(bici + ciclista +  
equipaggiamento) =  
135 kg.

## MOUNTAIN CONTROL (MC)

## MC32 LTD POWER (fino a MY2023)

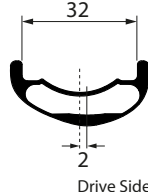
CERCHI	MODELLO	MATERIALE	TAGLIA	TIPOLOGIA CERCHIO	TIPOLOGIA FRENO	TUBELESS	LARGHEZZA INTERNA	OFFSET	FORI DIREZIONALI PER I RAGGI	FORATURA RAGGI	ERD	ETRTO	GIUNTO	LARGHEZZA NASTRO TUBELESS	VALVOLA	PNEUMATICI COMPATIBILI	PRESSIONE MASSIMA	SEZIONE
CERCHIO POSTERIORE	MC10-R-29-32H	Carbonio	29"	Copertoncino Hookless	Disco	Sì	30 mm	-2 mm	Sì	32	599,86 mm	622x30TSS	—	30 mm	44 mm 57 mm su Wild con magneti nella valvola	2,05"-2,8"	**	 32 2 Drive Side

RAGGI	No. RAGGI	MODELLO	RAGGIATURA DRIVE SIDE (dx)	RAGGIATURA NON-DRIVE SIDE (sx)	LUNGHEZZA RAGGI DRIVE SIDE (dx)	LUNGHEZZA RAGGI NON-DRIVE SIDE (sx)	TENSIONE ASSEMBLAGGIO DRIVE SIDE (dx)	TENSIONE ASSEMBLAGGIO LATO DISCO	RAGGIO "LEADING" DRIVE SIDE (dx)	RAGGIO "TRAILING" DRIVE SIDE (dx)	RAGGIO "LEADING" NON-DRIVE SIDE (sx)	RAGGIO "TRAILING" NON-DRIVE SIDE (sx)
POSTERIORE	32	Sapim E-Light. Rinforzato 14G (2 mm) J-Bend	3 incroci	3 incroci	292 mm	294 mm	1300 N	—	Interno	Esterno	Esterno	Interno

MOZZI	MODELLO	SPAZIATURA (VECCHIO)	ASSE	TIPO DISCO	RAGGI	CORPETTO RUOTA LIBERA	MECCANISMO RUOTA LIBERA	NIPPLI	MODELLO	MISURE	RONDELLE NIPPLI	PESO RUOTA	RUOTA	PESO	UTILIZZO
MOZZO POSTERIORE	DT SWISS 350 Hybrid Classic IS modello fino a MY2023	Boost 148 mm	Asse passante 12 mm	6 bulloni	32	Sram XD Shimano MS	Ratchet 24	POSTERIORE	Sapim Brass Polyax	2x14 mm (14G)	No	POSTERIORE	1042 g +/-5%	Condizione ASTM 5 (Vd. Manuale d'uso) Peso max del sistema (bici + ciclista + equipaggiamento) = <b>135 kg.</b>	

\*\* Per la pressione massima degli pneumatici, consultare il manuale d'uso o la decalcomania presente sulla ruota.

Fare clic o tap sul modello di mozzo o raggi per accedere alle informazioni sui ricambi

## MOUNTAIN CONTROL (MC)

## MC32 LTD POWER (a partire da MY2024)

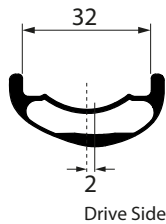
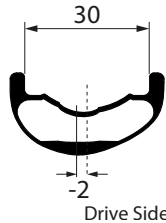
	MODELLO	MATERIALE	TAGLIA	TIPOLOGIA CERCHIO	TIPOLOGIA FRENO	TUBELESS	LARGHEZZA INTERNA	OFFSET	FORI DIREZIONALI PER I RAGGI	FORATURA RAGGI	ERD	ETRT0	GIUNTO	LARGHEZZA NASTRO TUBELESS	VALVOLA	PNEUMATICI COMPATIBILI	PRESSIONE MASSIMA	SEZIONE	
CERCHI	CERCHIO ANTERIORE	MC10-F-29-28H	Carbonio	29"	Copertoncino Hookless	Disco	Sì	32 mm	2 mm	Sì	28	604,26 mm	622x32TSS	—	32 mm	44 mm	2,4"-2,8"	**	
	CERCHIO POSTERIORE	MC10-R-29-32H	Carbonio	29"	Copertoncino Hookless	Disco	Sì	30 mm	-2 mm	Sì	32	599,86 mm	622x30TSS	—	30 mm	44 mm 57 mm su Wild con magneti nella valvola	2,05"-2,8"	**b	

	No. RAGGI	MODELLO	RAGGIATURA DRIVE SIDE (dx)	RAGGIATURA NON-DRIVE SIDE (sx)	LUNGHEZZA RAGGI DRIVE SIDE (dx)	LUNGHEZZA RAGGI NON-DRIVE SIDE (sx)	TENSIONE ASSEMBLAGGIO DRIVE SIDE (dx)	TENSIONE ASSEMBLAGGIO LATO DISCO	RAGGIO "LEADING" DRIVE SIDE (dx)	RAGGIO "TRAILING" DRIVE SIDE (dx)	RAGGIO "LEADING" NON-DRIVE SIDE (sx)	RAGGIO "TRAILING" NON-DRIVE SIDE (sx)	
RAGGI	ANTERIORE	28	Sapim E-Light. Rinforzato 14G (2 mm) J-Bend	3 incroci	3 incroci	299 mm	298 mm	—	1300 N	Esterno	Interno	Esterno	Interno
	POSTERIORE	32	Sapim E-Light. Rinforzato 14G (2 mm) J-Bend	3 incroci	3 incroci	291 mm	292 mm	1300 N	—	Interno	Esterno	Esterno	Interno

MOZZI	MODELLO	SPAZIATURA (VECCIO)	ASSE	TIPO DISCO	RAGGI	CORPETTO RUOTA LIBERA	MECCANISMO RUOTA LIBERA	NIPPOLI	MODELLO	MISURE	RONDELLE NIPPOLI	PESO RUOTA	RUOTA	PESO	UTILIZZO
	MOZZO ANTERIORE	DT SWISS 350 Hybrid Classic IS modello MY2024	Boost 110 mm	Asse passante 15 mm	6 bulloni	28	—		—	ANTERIORE	Sapim Brass Polyax		2x14 mm (14G)	No	
MOZZO POSTERIORE	DT SWISS 350 Hybrid Classic IS modello MY2024	Boost 148 mm	Asse passante 12 mm	6 bulloni	32	Sram XD Shimano MS	Ratchet 24	POSTERIORE	Sapim Brass Polyax	2x14 mm (14G)	No	POSTERIORE	1056 g +/-5%		

**Condizione ASTM 5**  
(Vd. Manuale d'uso)

Peso max del sistema  
(bici + ciclista +  
equipaggiamento) =  
**135 kg.**

\*\* Per la pressione massima degli pneumatici, consultare il manuale d'uso o la decalcomania presente sulla ruota.

Fare clic o tap sul modello di mozzo o raggio per accedere alle informazioni sui ricambi

## MOUNTAIN CONTROL (MC)

## MC32 TEAM (fino a MY2024)

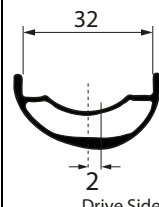
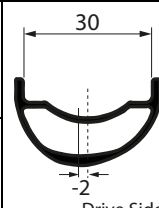
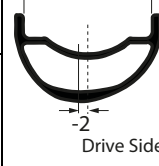
	MODELLO	MATERIALE	TAGLIA	TIPOLOGIA CERCHIO	TIPOLOGIA FRENO	TUBELESS	LARGHEZZA INTERNA	OFFSET	FORI DIREZIONALI PER I RAGGI	FORATURA RAGGI	ERD	ETRTO	GIUNTO	LARGHEZZA NASTRO TUBELESS	VALVOLA	PNEUMATICI COMPATIBILI	PRESSIONE MASSIMA	SEZIONE	
CERCHI	CERCHIO ANTERIORE 29"	MC30-F-29-28H	Alluminio AL6061	29"	Copertoncino Hookless	Disco	Sì	32 mm	2 mm	Sì	28	604 mm	622x32TSS	Sleeved (giuntato)	32 mm	44 mm	2,4"-2,8"	**	
	CERCHIO POSTERIORE 29"	MC30-R-29-32H	Alluminio AL6061	29"	Copertoncino Hookless	Disco	Sì	30 mm	-2 mm	Sì	32	600 mm	622x30TSS	Sleeved (giuntato)	30 mm	44 mm su Wild con magneti nella valvola	2,05"-2,8"	**	
	CERCHIO POSTERIORE 27,5"	MC31-R-27-32H	Alluminio AL6061	27,5"	Copertoncino Hookless	Disco	Sì	30 mm	-2 mm	Sì	32	561,6 mm	584x30TSS	Sleeved (giuntato)	30 mm	44 mm su Wild con magneti nella valvola	2,05"-2,8"	**	

	No. RAGGI	MODELLO	RAGGIATURA DRIVE SIDE (dx)	RAGGIATURA NON-DRIVE SIDE (sx)	LUNGHEZZA RAGGI DRIVE SIDE (dx)	LUNGHEZZA RAGGI NON-DRIVE SIDE (sx)	TENSIONE ASSEMBLAGGIO DRIVE SIDE (dx)	TENSIONE ASSEMBLAGGIO LATO DISCO	RAGGIO "LEADING" DRIVE SIDE (dx)	RAGGIO "TRAILING" DRIVE SIDE (dx)	RAGGIO "LEADING" NON-DRIVE SIDE (sx)	RAGGIO "TRAILING" NON-DRIVE SIDE (sx)	
RAGGI	ANTERIORE 29"	28	Sapim D-Sprint Rinf. 14G (2 mm). J-Bend	3 incroci	3 incroci	299 mm	297 mm	—	1200 N	Esterno	Interno	Esterno	Interno
	POSTERIORE 29"	32	Sapim Race Rinforzati. 14G (2 mm). J-Bend	3 incroci	3 incroci	291 mm	291 mm	1200 N	—	Interno	Esterno	Esterno	Interno
	POSTERIORE 27,5"	32	Sapim Race Rinforzati. 14G (2 mm). J-Bend	3 incroci	3 incroci	271 mm	271 mm	1200 N	—	Interno	Esterno	Esterno	Interno

	MODELLO	SPAZIATURA (VECCHIO)	ASSE	TIPO DISCO	RAGGI	CORPETTO RUOTA LIBERA	MECCANISMO RUOTA LIBERA
MOZZI	ANTERIORE 29"	DT SWISS 350 Classic IS	Boost 110 mm	Asse passante 15 mm	6 bulloni	28 J-Bend	—
	POSTERIORE 29"	DT SWISS 350 Classic IS	Boost 148 mm	Asse passante 12 mm	6 bulloni	32 J-Bend	Sram XD o Shimano MS
	POSTERIORE 27,5"	DT SWISS 350 Classic IS	Boost 148 mm	Asse passante 12 mm	6 bulloni	32 J-Bend	Sram XD o Shimano MS

	MODELLO	MISURE	RONDELLE NIPPLI	
NIPPLI	ANTERIORE 29"	Sapim Brass Polyax	2x14 mm (14G)	No
	POSTERIORE 29"	Sapim Brass Polyax	2x14 mm (14G)	No
	POSTERIORE 27,5"	Sapim Brass Polyax	2x14 mm (14G)	No

	RUOTA	PESO
PESO RUOTA	ANTERIORE 29"	898 g +/-5%
	POSTERIORE 29"	1046 g +/-5%
	POSTERIORE 27,5"	1010 g +/-5%

UTILIZZO
<p><b>Condizione ASTM 5</b> (Vd. Manuale d'uso)</p> <p>Peso max del sistema (bici + ciclista + equipaggiamento) = <b>135 kg.</b></p>

## MOUNTAIN CONTROL (MC)

## MC32 TEAM (MY2025)

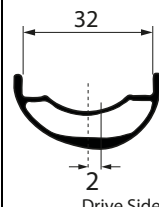
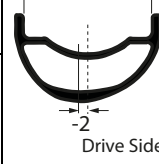
	MODELLO	MATERIALE	TAGLIA	TIPOLOGIA CERCHIO	TIPOLOGIA FRENO	TUBELESS	LARGHEZZA INTERNA	OFFSET	FORI DIREZIONALI PER I RAGGI	FORATURA RAGGI	ERD	ETRTO	GIUNTO	LARGHEZZA NASTRO TUBELESS	VALVOLA	PNEUMATICI COMPATIBILI	PRESSIONE MASSIMA	SEZIONE	
CERCHI	CERCHIO ANTERIORE 29"	MC36-F-29-28H	Alluminio AL6061	29"	Copertoncino Hookless	Disco	Sì	32 mm	2 mm	Sì	28	612,3 mm	622x32TSS	Sleeved (giuntato)	32 mm	44 mm	2,4"-2,8"	**	
	CERCHIO POSTERIORE 29"	MC36-R-29-32H	Alluminio AL6061	29"	Copertoncino Hookless	Disco	Sì	30 mm	-2 mm	Sì	32	610,9 mm	622x30TSS	Sleeved (giuntato)	30 mm	44 mm su Wild con magneti nella valvola	2,05"-2,8"	**	
	CERCHIO POSTERIORE 27,5"	MC37-R-27-32H	Alluminio AL6061	27,5"	Copertoncino Hookless	Disco	Sì	30 mm	-2 mm	Sì	32	572,9 mm	584x30TSS	Sleeved (giuntato)	30 mm	44 mm su Wild con magneti nella valvola	2,05"-2,8"	**	

	No. RAGGI	MODELLO	RAGGIATURA DRIVE SIDE (dx)	RAGGIATURA NON-DRIVE SIDE (sx)	LUNGHEZZA RAGGI DRIVE SIDE (dx)	LUNGHEZZA RAGGI NON-DRIVE SIDE (sx)	TENSIONE ASSEMBLAGGIO DRIVE SIDE (dx)	TENSIONE ASSEMBLAGGIO LATO DISCO	RAGGIO "LEADING" DRIVE SIDE (dx)	RAGGIO "TRAILING" DRIVE SIDE (dx)	RAGGIO "LEADING" NON-DRIVE SIDE (sx)	RAGGIO "TRAILING" NON-DRIVE SIDE (sx)	
RAGGI	ANTERIORE 29"	28	Sapim D-Light Rinforzati. 14G (2 mm). J-Bend	3 incroci	3 incroci	302 mm	300 mm	—	1300 N	Esterno	Interno	Esterno	Interno
	POSTERIORE 29"	32	Sapim Sprint Rinforzati. 14G (2 mm). J-Bend	3 incroci	3 incroci	295 mm	295 mm	1300 N	—	Interno	Esterno	Esterno	Interno
	POSTERIORE 27,5"	32	Sapim Sprint Rinforzati. 14G (2 mm). J-Bend	3 incroci	3 incroci	276 mm	276 mm	1300 N	—	Interno	Esterno	Esterno	Interno

	MODELLO	SPAZIATURA (VECCHIO)	ASSE	TIPO DISCO	RAGGI	CORPETTO RUOTA LIBERA	MECCANISMO RUOTA LIBERA
MOZZI	ANTERIORE 29"	DT SWISS 350 Classic IS	Boost 110 mm	Asse passante 15 mm	6 bulloni	28 J-Bend	—
	POSTERIORE 29"	DT SWISS 350 Classic IS	Boost 148 mm	Asse passante 12 mm	6 bulloni	32 J-Bend	Sram XD o Shimano MS
	POSTERIORE 27,5"	DT SWISS 350 Classic IS	Boost 148 mm	Asse passante 12 mm	6 bulloni	32 J-Bend	Sram XD o Shimano MS

	MODELLO	MISURE	RONDELLE NIPPLI	
NIPPLI	ANTERIORE 29"	Sapim Alloy Double Square	2x18 mm (14G)	No
	POSTERIORE 29"	Sapim Alloy Double Square	2x18 mm (14G)	No
	POSTERIORE 27,5"	Sapim Alloy Double Square	2x18 mm (14G)	No

	RUOTA	PESO
PESO RUOTA	ANTERIORE 29"	970 g +/-5%
	POSTERIORE 29"	1108 g +/-5%
	POSTERIORE 27,5"	1055 g +/-5%

UTILIZZO
<p><b>Condizione ASTM 5</b> (Vd. Manuale d'uso)</p> <p>Peso max del sistema (bici + ciclista + equipaggiamento) = <b>135 kg.</b></p>

## MOUNTAIN CONTROL (MC)

## MC32 TEAM (da MY2026)

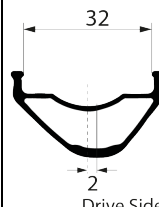
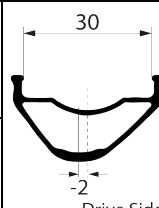
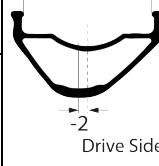
	MODELLO	MATERIALE	TAGLIA	TIPOLOGIA CERCHIO	TIPOLOGIA FRENO	TUBELESS	LARGHEZZA INTERNA	OFFSET	FORI DIREZIONALI PER I RAGGI	FORATURA RAGGI	ERD	ETRT0	GIUNTO	LARGHEZZA NASTRO TUBELESS	VALVOLA	PNEUMATICI COMPATIBILI	PRESSIONE MASSIMA	SEZIONE	
CERCHI	CERCHIO ANTERIORE 29"	MC36-F-29-28H	Alluminio AL6061	29"	Copertoncino Minihook	Disco	Sì	32 mm	2 mm	Sì	28	612,3 mm	622x32TSS	Sleeved (giuntato)	32 mm	44 mm	2,4"-2,8"	**	
	CERCHIO POSTERIORE 29"	MC36-R-29-32H	Alluminio AL6061	29"	Copertoncino Minihook	Disco	Sì	30 mm	-2 mm	Sì	32	610,9 mm	622x30TSS	Sleeved (giuntato)	30 mm	44 mm su Wild con magneti nella valvola	2,05"-2,8"	**	
	CERCHIO POSTERIORE 27,5"	MC37-R-27-32H	Alluminio AL6061	27,5"	Copertoncino Minihook	Disco	Sì	30 mm	-2 mm	Sì	32	572,9 mm	584x30TSS	Sleeved (giuntato)	30 mm	44 mm su Wild con magneti nella valvola	2,05"-2,8"	**	

	No. RAGGI	MODELLO	RAGGIATURA DRIVE SIDE (dx)	RAGGIATURA NON-DRIVE SIDE (sx)	LUNGHEZZA RAGGI DRIVE SIDE (dx)	LUNGHEZZA RAGGI NON-DRIVE SIDE (sx)	TENSIONE ASSEMBLAGGIO DRIVE SIDE (dx)	TENSIONE ASSEMBLAGGIO LATO DISCO	RAGGIO "LEADING" DRIVE SIDE (dx)	RAGGIO "TRAILING" DRIVE SIDE (dx)	RAGGIO "LEADING" NON-DRIVE SIDE (sx)	RAGGIO "TRAILING" NON-DRIVE SIDE (sx)	
RAGGI	ANTERIORE 29"	28	Sapim D-Light Rinforzati. 14G (2 mm). J-Bend	3 incroci	3 incroci	298 mm	297 mm	—	1300 N	Esterno	Interno	Esterno	Interno
	POSTERIORE 29"	32	Sapim Sprint Rinforzati. 14G (2 mm). J-Bend	3 incroci	3 incroci	291 mm	291 mm	1300 N	—	Interno	Esterno	Esterno	Interno
	POSTERIORE 27,5"	32	Sapim Sprint Rinforzati. 14G (2 mm). J-Bend	3 incroci	3 incroci	272 mm	272 mm	1300 N	—	Interno	Esterno	Esterno	Interno

	MODELLO	SPAZIATURA (VECCHIO)	ASSE	TIPO DISCO	RAGGI	CORPETTO RUOTA LIBERA	MECCANISMO RUOTA LIBERA
MOZZI	ANTERIORE 29"	OQUO LTD DT 350 INSIDE	Boost 110 mm	Asse passante 15 mm	6 bulloni	28 J-Bend	—
	POSTERIORE 29"	OQUO LTD DT 350 DEG INSIDE	Boost 148 mm	Asse passante 12 mm	6 bulloni	32 J-Bend	Sram XD o Shimano MS Ratchet DEG 72
	POSTERIORE 27,5"	OQUO LTD DT 350 DEG INSIDE	Boost 148 mm	Asse passante 12 mm	6 bulloni	32 J-Bend	Sram XD o Shimano MS Ratchet DEG 72

	MODELLO	MISURE	RONDELLE NIPPLI	
NIPPLI	ANTERIORE 29"	Sapim Alloy Double Square	2x18 mm (14G)	No
	POSTERIORE 29"	Sapim Alloy Double Square	2x18 mm (14G)	No
	POSTERIORE 27,5"	Sapim Alloy Double Square	2x18 mm (14G)	No

	RUOTA	PESO
PESO RUOTA	ANTERIORE 29"	950 g +/-5%
	POSTERIORE 29"	1125 g +/-5%
	POSTERIORE 27,5"	1075 g +/-5%

UTILIZZO
<p><b>Condizione ASTM 5</b> (Vd. Manuale d'uso)</p> <p>Peso max del sistema (bici + ciclista + equipaggiamento) = <b>135 kg.</b></p>

## MOUNTAIN CONTROL (MC)

## MC32 TEAM RALLON DH MY2026 (OEM)

## AVVISO

Questo set ruote MC32 TEAM è disponibile solo sulle configurazioni complete della Orbea Rallon DH MY2026.

	MODELLO	MATERIALE	TAGLIA	TIPOLOGIA CERCHIO	TIPOLOGIA FRENO	TUBELESS	LARGHEZZA INTERNA	OFFSET	FORI DIREZIONALI PER I RAGGI	FORATURA RAGGI	ERD	ETRTO	GIUNTO	LARGHEZZA NASTRO TUBELESS	VALVOLA	PNEUMATICI COMPATIBILI	PRESSIONE MASSIMA	SEZIONE	
CERCHI	CERCHIO ANTERIORE 29"	MC36-F-29-28H	Alluminio AL6061	29"	Copertoncino Minihook	Disco	Sì	32 mm	2 mm	Sì	28	612,3 mm	622x32TSS	Sleeved (giuntato)	32 mm	44 mm	2,4"-2,8"	**	
	CERCHIO POSTERIORE 27,5"	MC37-R-27-32H	Alluminio AL6061	27,5"	Copertoncino Minihook	Disco	Sì	30 mm	-2 mm	Sì	32	572,9 mm	584x30TSS	Sleeved (giuntato)	30 mm	44 mm su Wild con magneti nella valvola	2,05"-2,8"	**	

	No. RAGGI	MODELLO	RAGGIATURA DRIVE SIDE (dx)	RAGGIATURA NON-DRIVE SIDE (sx)	LUNGHEZZA RAGGI DRIVE SIDE (dx)	LUNGHEZZA RAGGI NON-DRIVE SIDE (sx)	TENSIONE ASSEMBLAGGIO DRIVE SIDE (dx)	TENSIONE ASSEMBLAGGIO LATO DISCO	RAGGIO "LEADING" DRIVE SIDE (dx)	RAGGIO "TRAILING" DRIVE SIDE (dx)	RAGGIO "LEADING" NON-DRIVE SIDE (sx)	RAGGIO "TRAILING" NON-DRIVE SIDE (sx)
RAGGI	ANTERIORE 29"	Sapim Race Rinforzati. 14G (2 mm). J-Bend	3 incroci	3 incroci	296 mm	296 mm	—	1300 N	Esterno	Interno	Esterno	Interno
	POSTERIORE 27,5"	Sapim Race Rinforzati. 14G (2 mm). J-Bend	3 incroci	3 incroci	272 mm	272 mm	1300 N	—	Interno	Esterno	Esterno	Interno

MOZZI	MODELLO	SPAZIATURA (VECCIO)	ASSE	TIPO DISCO	RAGGI	CORPETTO RUOTA LIBERA	MECCANISMO RUOTA LIBERA	NIPPLI	MODELLO	MISURE	RONDELLE NIPPLI	PESO RUOTA	RUOTA	PESO	UTILIZZO
	ANTERIORE 29"	DT SWISS 350 Classic IS	Boost 110 mm	Asse passante 20 mm	6 bulloni	28 J-Bend	—		—	ANTERIORE 29"	Sapim Brass Polyax		2x14 mm (14G)	No	
POSTERIORE 27,5"	DT SWISS 350 Classic IS	Boost 148 mm	Asse passante 12 mm	6 bulloni	32 J-Bend	Shimano HG	Ratchet 36 SL	POSTERIORE 27,5"	Sapim Brass Polyax	2x14 mm (14G)	No	POSTERIORE 27,5"	1055 g +/-5%		

Condizione ASTM 5 (Vd. Manuale d'uso)

Peso max del sistema (bici + ciclista + equipaggiamento) = **135 kg.**

## MOUNTAIN CONTROL (MC)

## MC32 TEAM POWER (fino a MY2023)

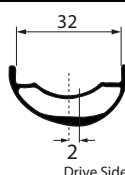
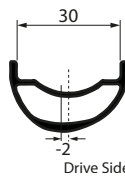
	MODELLO	MATERIALE	TAGLIA	TIPOLOGIA CERCHIO	TIPOLOGIA FRENO	TUBELESS	LARGHEZZA INTERNA	OFFSET	FORI DIREZIONALI PER I RAGGI	FORATURA RAGGI	ERD	ETRTO	GIUNTO	LARGHEZZA NASTRO TUBELESS	VALVOLA	PNEUMATICI COMPATIBILI	PRESSIONE MASSIMA	SEZIONE	
CERCHI	CERCHIO ANTERIORE	MC31-F-29-32H	Alluminio AL6061	29"	Copertoncino Hookless	Disco	Sì	32 mm	2 mm	Sì	32	604 mm	622x32TSS	Sleeved (giuntato)	32 mm	44 mm	2,4"-2,8"	**	
	CERCHIO POSTERIORE	MC30-R-29-32H	Alluminio AL6061	29"	Copertoncino Hookless	Disco	Sì	30 mm	-2 mm	Sì	32	600 mm	622x30TSS	Sleeved (giuntato)	30 mm	44 mm 57 mm su Wild con magneti nella valvola	2,05"-2,8"	**	

	No. RAGGI	MODELLO	RAGGIATURA DRIVE SIDE (dx)	RAGGIATURA NON-DRIVE SIDE (sx)	LUNGHEZZA RAGGI DRIVE SIDE (dx)	LUNGHEZZA RAGGI NON-DRIVE SIDE (sx)	TENSIONE ASSEMBLAGGIO DRIVE SIDE (dx)	TENSIONE ASSEMBLAGGIO LATO DISCO	RAGGIO "LEADING" DRIVE SIDE (dx)	RAGGIO "TRAILING" DRIVE SIDE (dx)	RAGGIO "LEADING" NON-DRIVE SIDE (sx)	RAGGIO "TRAILING" NON-DRIVE SIDE (sx)	
RAGGI	ANTERIORE	32	Sapim E-Light. Rinforzato 14G (2 mm) J-Bend	3 incroci	3 incroci	294 mm	292 mm	—	1200 N	Esterno	Interno	Esterno	Interno
	POSTERIORE	32	Sapim E-Light. Rinforzato 14G (2 mm) J-Bend	3 incroci	3 incroci	291 mm	293 mm	1200 N	—	Interno	Esterno	Esterno	Interno

MOZZI	MODELLO	SPAZIATURA (VECCHIO)	ASSE	TIPO DISCO	RAGGI	CORPETTO RUOTA LIBERA	MECCANISMO RUOTA LIBERA	NIPPLI	MODELLO	MISURE	RONDELLE NIPPLI	PESO RUOTA	RUOTA	PESO	UTILIZZO
	MOZZO ANTERIORE	DT SWISS 350 Hybrid Classic IS modello fino a MY2023	Boost 110 mm	Asse passante 15 mm	6 bulloni	32	—		—	ANTERIORE	Sapim Brass Polyax		2x14 mm (14G)	No	
MOZZO POSTERIORE	DT SWISS 350 Hybrid Classic IS modello fino a MY2023	Boost 148 mm	Asse passante 12 mm	6 bulloni	32	Sram XD Shimano MS	Ratchet 24	POSTERIORE	Sapim Brass Polyax	2x14 mm (14G)	No	POSTERIORE	1060 g +/-5%		



**Condizione ASTM 5**  
(Vd. Manuale d'uso)  
Peso max del sistema  
(bici + ciclista +  
equipaggiamento) =  
**135 kg.**

\*\* Per la pressione massima degli pneumatici, consultare il manuale d'uso o la decalcomania presente sulla ruota.

Fare clic o tap sul modello di mozzo o raggio per accedere alle informazioni sui ricambi

## MOUNTAIN CONTROL (MC)

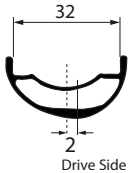
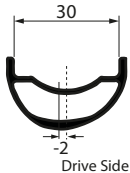
## MC32 TEAM POWER (MY2024)

	MODELLO	MATERIALE	TAGLIA	TIPOLOGIA CERCHIO	TIPOLOGIA FRENO	TUBELESS	LARGHEZZA INTERNA	OFFSET	FORI DIREZIONALI PER I RAGGI	FORATURA RAGGI	ERD	ETRTO	GIUNTO	LARGHEZZA NASTRO TUBELESS	VALVOLA	PNEUMATICI COMPATIBILI	PRESSIONE MASSIMA	SEZIONE	
CERCHI	CERCHIO ANTERIORE 29"	MC30-F-29-28H	Alluminio AL6061	29"	Copertoncino Hookless	Disco	Sì	32 mm	2 mm	Sì	28	604 mm	622x32TSS	Sleeved (giuntato)	32 mm	44 mm	2,4"-2,8"	**	
	CERCHIO POSTERIORE 29"	MC30-R-29-32H	Alluminio AL6061	29"	Copertoncino Hookless	Disco	Sì	30 mm	-2 mm	Sì	32	600 mm	622x30TSS	Sleeved (giuntato)	30 mm	44 mm su Wild con magneti nella valvola	2,05"-2,8"	**	
	CERCHIO POSTERIORE 27,5"	MC31-R-27-32H	Alluminio AL6061	27,5"	Copertoncino Hookless	Disco	Sì	30 mm	-2 mm	Sì	32	561,6 mm	584x30TSS	Sleeved (giuntato)	30 mm	44 mm su Wild con magneti nella valvola	2,05"-2,8"	**	

	No. RAGGI	MODELLO	RAGGIATURA DRIVE SIDE (dx)	RAGGIATURA NON-DRIVE SIDE (sx)	LUNGHEZZA RAGGI DRIVE SIDE (dx)	LUNGHEZZA RAGGI NON-DRIVE SIDE (sx)	TENSIONE ASSEMBLAGGIO DRIVE SIDE (dx)	TENSIONE ASSEMBLAGGIO LATO DISCO	RAGGIO "LEADING" DRIVE SIDE (dx)	RAGGIO "TRAILING" DRIVE SIDE (dx)	RAGGIO "LEADING" NON-DRIVE SIDE (sx)	RAGGIO "TRAILING" NON-DRIVE SIDE (sx)	
RAGGI	ANTERIORE 29"	28	Sapim E-Light. Rinforzato 14G (2 mm) J-Bend	3 incroci	3 incroci	298 mm	297 mm	—	1200 N	Esterno	Interno	Esterno	Interno
	POSTERIORE 29"	32	Sapim E-Light. Rinforzato 14G (2 mm) J-Bend	3 incroci	3 incroci	291 mm	292 mm	1200 N	—	Interno	Esterno	Esterno	Interno
	POSTERIORE 27,5"	32	Sapim E-Light. Rinforzato 14G (2 mm) J-Bend	3 incroci	3 incroci	271 mm	271 mm	1200 N	—	Interno	Esterno	Esterno	Interno

	MODELLO	SPAZIATURA (VECHIO)	ASSE	TIPO DISCO	RAGGI	CORPETTO RUOTA LIBERA	MECCANISMO RUOTA LIBERA
MOZZI	ANTERIORE 29"	DT SWISS 350 Hybrid Classic IS modello MY2024	Boost 110 mm	Asse passante 15 mm	6 bulloni	28 J-Bend	—
	POSTERIORE 29"	DT SWISS 350 Hybrid Classic IS modello MY2024	Boost 148 mm	Asse passante 12 mm	6 bulloni	32 J-Bend	Sram XD o Shimano MS
	POSTERIORE 27,5"	DT SWISS 350 Hybrid Classic IS modello MY2024	Boost 148 mm	Asse passante 12 mm	6 bulloni	32 J-Bend	Sram XD o Shimano MS



	MODELLO	MISURE	RONDILLE NIPPLI	
NIPPLI	ANTERIORE 29"	Sapim Brass Polyax	2x14 mm (14G)	No
	POSTERIORE 29"	Sapim Brass Polyax	2x14 mm (14G)	No
	POSTERIORE 27,5"	Sapim Brass Polyax	2x14 mm (14G)	No

	RUOTA	PESO
PESO RUOTA	ANTERIORE 29"	985 g +/-5%
	POSTERIORE 29"	1160 g +/-5%
	POSTERIORE 27,5"	1085 g +/-5%

UTILIZZO
<p><b>Condizione ASTM 5</b> (Vd. Manuale d'uso)</p> <p>Peso max del sistema (bici + ciclista + equipaggiamento) = <b>135 kg.</b></p>

## MOUNTAIN CONTROL (MC)

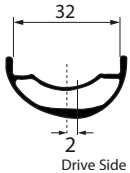
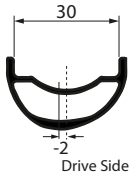
## MC32 TEAM POWER (MY2025)

	MODELLO	MATERIALE	TAGLIA	TIPOLOGIA CERCHIO	TIPOLOGIA FRENO	TUBELESS	LARGHEZZA INTERNA	OFFSET	FORI DIREZIONALI PER I RAGGI	FORATURA RAGGI	ERD	ETRTO	GIUNTO	LARGHEZZA NASTRO TUBELESS	VALVOLA	PNEUMATICI COMPATIBILI	PRESSIONE MASSIMA	SEZIONE	
CERCHI	CERCHIO ANTERIORE 29"	MC36-F-29-28H	Alluminio AL6061	29"	Copertoncino Hookless	Disco	Si	32 mm	2 mm	Si	28	612,3 mm	622x32TSS	Sleeved (giuntato)	32 mm	44 mm	2,4"-2,8"	**	
	CERCHIO POSTERIORE 29"	MC36-R-29-32H	Alluminio AL6061	29"	Copertoncino Hookless	Disco	Si	30 mm	-2 mm	Si	32	610,9 mm	622x30TSS	Sleeved (giuntato)	30 mm	44 mm su Wild con magneti nella valvola	2,05"-2,8"	**	
	CERCHIO POSTERIORE 27,5"	MC37-R-27-32H	Alluminio AL6061	27,5"	Copertoncino Hookless	Disco	Si	30 mm	-2 mm	Si	32	572,9 mm	584x30TSS	Sleeved (giuntato)	30 mm	44 mm su Wild con magneti nella valvola	2,05"-2,8"	**	

	No. RAGGI	MODELLO	RAGGIATURA DRIVE SIDE (dx)	RAGGIATURA NON-DRIVE SIDE (sx)	LUNGHEZZA RAGGI DRIVE SIDE (dx)	LUNGHEZZA RAGGI NON-DRIVE SIDE (sx)	TENSIONE ASSEMBLAGGIO DRIVE SIDE (dx)	TENSIONE ASSEMBLAGGIO LATO DISCO	RAGGIO "LEADING" DRIVE SIDE (dx)	RAGGIO "TRAILING" DRIVE SIDE (dx)	RAGGIO "LEADING" NON-DRIVE SIDE (sx)	RAGGIO "TRAILING" NON-DRIVE SIDE (sx)	
RAGGI	ANTERIORE 29"	28	Sapim E-Light. Rinforzato 14G (2 mm) J-Bend	3 incroci	3 incroci	301 mm	300 mm	—	1300 N	Esterno	Interno	Esterno	Interno
	POSTERIORE 29"	32	Sapim E-Light. Rinforzato 14G (2 mm) J-Bend	3 incroci	3 incroci	294 mm	295 mm	1300 N	—	Interno	Esterno	Esterno	Interno
	POSTERIORE 27,5"	32	Sapim E-Light. Rinforzato 14G (2 mm) J-Bend	3 incroci	3 incroci	275 mm	276 mm	1300 N	—	Interno	Esterno	Esterno	Interno

	MODELLO	SPAZIATURA (VECCHIO)	ASSE	TIPO DISCO	RAGGI	CORPETTO RUOTA LIBERA	MECCANISMO RUOTA LIBERA
MOZZI	ANTERIORE 29"	DT SWISS 350 Hybrid Classic IS modello MY2024	Boost 110 mm	Asse passante 15 mm	6 bulloni	28 J-Bend	—
	POSTERIORE 29"	DT SWISS 350 Hybrid Classic IS modello MY2024	Boost 148 mm	Asse passante 12 mm	6 bulloni	32 J-Bend	Sram XD o Shimano MS
	POSTERIORE 27,5"	DT SWISS 350 Hybrid Classic IS modello MY2024	Boost 148 mm	Asse passante 12 mm	6 bulloni	32 J-Bend	Sram XD o Shimano MS

	MODELLO	MISURE	RONDELLE NIPPLI	
NIPPLI	ANTERIORE 29"	Sapim Alloy Double Square	2x18 mm (14G)	No
	POSTERIORE 29"	Sapim Alloy Double Square	2x18 mm (14G)	No
	POSTERIORE 27,5"	Sapim Alloy Double Square	2x18 mm (14G)	No

	RUOTA	PESO
PESO RUOTA	ANTERIORE 29"	1030 g +/-5%
	POSTERIORE 29"	1180 g +/-5%
	POSTERIORE 27,5"	1130 g +/-5%

UTILIZZO
<p><b>Condizione ASTM 5</b> (Vd. Manuale d'uso)</p> <p>Peso max del sistema (bici + ciclista + equipaggiamento) = <b>135 kg.</b></p>

## MOUNTAIN CONTROL (MC)

## MC32 TEAM POWER (da MY2026)

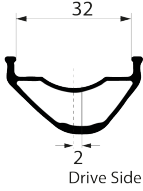
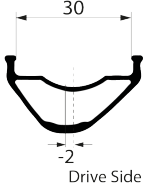
	MODELLO	MATERIALE	TAGLIA	TIPOLOGIA CERCHIO	TIPOLOGIA FRENO	TUBELESS	LARGHEZZA INTERNA	OFFSET	FORI DIREZIONALI PER I RAGGI	FORATURA RAGGI	ERD	ETRTO	GIUNTO	LARGHEZZA NASTRO TUBELESS	VALVOLA	PNEUMATICI COMPATIBILI	PRESSIONE MASSIMA	SEZIONE	
CERCHI	CERCHIO ANTERIORE 29"	MC36-F-29-28H	Alluminio AL6061	29"	Copertoncino Minihook	Disco	Sì	32 mm	2 mm	Sì	28	612,3 mm	622x32TSS	Sleeved (giuntato)	32 mm	44 mm	2,4"-2,8"	**	
	CERCHIO POSTERIORE 29"	MC36-R-29-32H	Alluminio AL6061	29"	Copertoncino Minihook	Disco	Sì	30 mm	-2 mm	Sì	32	610,9 mm	622x30TSS	Sleeved (giuntato)	30 mm	44 mm su Wild con magneti nella valvola	2,05"-2,8"	**	
	CERCHIO POSTERIORE 27,5"	MC37-R-27-32H	Alluminio AL6061	27,5"	Copertoncino Minihook	Disco	Sì	30 mm	-2 mm	Sì	32	572,9 mm	584x30TSS	Sleeved (giuntato)	30 mm	44 mm su Wild con magneti nella valvola	2,05"-2,8"	**	

	No. RAGGI	MODELLO	RAGGIATURA DRIVE SIDE (dx)	RAGGIATURA NON-DRIVE SIDE (sx)	LUNGHEZZA RAGGI DRIVE SIDE (dx)	LUNGHEZZA RAGGI NON-DRIVE SIDE (sx)	TENSIONE ASSEMBLAGGIO DRIVE SIDE (dx)	TENSIONE ASSEMBLAGGIO LATO DISCO	RAGGIO "LEADING" DRIVE SIDE (dx)	RAGGIO "TRAILING" DRIVE SIDE (dx)	RAGGIO "LEADING" NON-DRIVE SIDE (sx)	RAGGIO "TRAILING" NON-DRIVE SIDE (sx)
RAGGI	ANTERIORE 29"	Sapim E-Light. Rinforzato 14G (2 mm) J-Bend	3 incroci	3 incroci	301 mm	300 mm	—	1300 N	Esterno	Interno	Esterno	Interno
	POSTERIORE 29"	Sapim E-Light. Rinforzato 14G (2 mm) J-Bend	3 incroci	3 incroci	294 mm	295 mm	1300 N	—	Interno	Esterno	Esterno	Interno
	POSTERIORE 27,5"	Sapim E-Light. Rinforzato 14G (2 mm) J-Bend	3 incroci	3 incroci	275 mm	276 mm	1300 N	—	Interno	Esterno	Esterno	Interno

	MODELLO	SPAZIATURA (VECCHIO)	ASSE	TIPO DISCO	RAGGI	CORPETTO RUOTA LIBERA	MECCANISMO RUOTA LIBERA
MOZZI	ANTERIORE 29"	DT SWISS 350 Hybrid Classic IS modello MY2024	Boost 110 mm	Asse passante 15 mm	6 bulloni	28 J-Bend	—
	POSTERIORE 29"	DT SWISS 350 Hybrid Classic IS modello MY2024	Boost 148 mm	Asse passante 12 mm	6 bulloni	32 J-Bend	Sram XD o Shimano MS
	POSTERIORE 27,5"	DT SWISS 350 Hybrid Classic IS modello MY2024	Boost 148 mm	Asse passante 12 mm	6 bulloni	32 J-Bend	Sram XD o Shimano MS

	MODELLO	MISURE	RONDELLE NIPPLI	
NIPPLI	ANTERIORE 29"	Sapim Alloy Double Square	2x18 mm (14G)	No
	POSTERIORE 29"	Sapim Alloy Double Square	2x18 mm (14G)	No
	POSTERIORE 27,5"	Sapim Alloy Double Square	2x18 mm (14G)	No

	RUOTA	PESO
PESO RUOTA	ANTERIORE 29"	1030 g +/-5%
	POSTERIORE 29"	1180 g +/-5%
	POSTERIORE 27,5"	1130 g +/-5%

UTILIZZO
<p><b>Condizione ASTM 5</b> (Vd. Manuale d'uso)</p> <p>Peso max del sistema (bici + ciclista + equipaggiamento) = <b>135 kg.</b></p>

---

## MANUTENZIONE DELLE RUOTE OQUO

Le informazioni contenute nel presente manuale sono principalmente destinate ai distributori OQUO e agli utenti con esperienza nella manutenzione delle ruote.

Se un utente non dispone delle conoscenze e competenze per eseguire le procedure di manutenzione descritte nel presente manuale tecnico o per montare i ricambi elencati, le riparazioni e la manutenzione delle ruote dovranno essere affidate a un rivenditore OQUO.

Le informazioni di contatto dei distributori sono disponibili sul nostro sito web.

[www.oquowheels.com](http://www.oquowheels.com)

### AVVISO

I danni causati da operazioni di manutenzione o riparazione inadeguate non sono coperti dalle condizioni di garanzia.



Interventi errati di riparazione, manutenzione o montaggio dei componenti possono avere effetti negativi su integrità e funzionamento delle ruote, e causare incidenti con lesioni gravi o letali.

### STRUMENTI

Utilizzare sempre i prodotti o gli strumenti adeguati per una specifica operazione di manutenzione o riparazione. Strumenti non adatti o soggetti a scarsa manutenzione, oppure l'utilizzo di prodotti generici, possono causare danni ai componenti non coperti dalle condizioni di garanzia.

Attenersi alla tabella relativa ai periodi di manutenzione presente nel manuale per i controlli e gli intervalli di manutenzione delle ruote e dei loro componenti.

Consultare la sezione sulla manutenzione dei mozzi contenuta in questo manuale per i manuali di manutenzione dei produttori dei mozzi.

### TABELLA DEL PROGRAMMA DI MANUTENZIONE

Attenersi alla seguente tabella per i controlli e gli intervalli di manutenzione delle ruote e dei loro componenti.

### AVVISO

Gli intervalli di manutenzione dei componenti indicati di seguito valgono come riferimento generale, e dipendono in gran parte da fattori come le condizioni meteo in cui si usa la bicicletta (le condizioni avverse riducono notevolmente la durata dei componenti e aumentano la frequenza della manutenzione), la pulizia della bicicletta e dei suoi componenti (i componenti con sporco accumulato si usurano più velocemente), e l'uso (un uso più impegnativo della bicicletta richiede intervalli di manutenzione più brevi).

I danni ai componenti causati dalla non osservanza degli intervalli di manutenzione non sono coperti dalle condizioni di garanzia.

Gli strumenti da usare sono specificati nel presente manuale, oppure viene fornito un riferimento ai manuali di manutenzione del produttore dei componenti usati nella nostra ruota, nei quali sono descritti gli strumenti appropriati.

CONTROLLO	FREQUENZA		
	Prima di ogni utilizzo	Ogni 2-3 utilizzi	Ogni 4-6 mesi (40-60 ore) */**
Pulire le ruote con acqua e sapone o con prodotti specifici per la pulizia delle biciclette.		✓	✓
Verifica del serraggio e delle condizioni degli assi passanti o degli assi a sgancio rapido	✓		
Verifica delle condizioni dei dischi dei freni	✓		
Verifica del serraggio dei dischi dei freni			✓
Verifica della centratura dei cerchi	✓		✓
Ispezione delle condizioni degli pneumatici (tagli e usura)	✓		
Controllo manuale della tensione e delle condizioni dei raggi	✓		
Controllo manuale della rotazione e del gioco dei mozzi del corpo della ruota libera	✓		
Verifica della pressione di gonfiaggio e delle perdite d'aria	✓		
Ricerca di eventuali danni a cerchi, mozzi e raggi	✓		✓
Ispezione e/o rabbocco del sigillante negli pneumatici tubeless			✓
Pulizia del sigillante liquido nel cerchio, nello pneumatico e nella valvola			✓
Sostituzione del nastro del cerchio (standard o tubeless), se necessario			✓
Controllo della tensione dei raggi con tensiometro			✓
Ispezione del funzionamento del mozzo, manutenzione dei cuscinetti e del corpo mozzo nel rispetto delle istruzioni del produttore, se necessario.			✓
Sostituzione camere d'aria sugli pneumatici standard			✓

\*I tempi potranno essere più brevi a seconda dello stile di guida e delle condizioni di utilizzo.

\*\*Gli utenti più pesanti o coloro che utilizzano le ruote in prossimità dei loro limiti di peso potrebbero dover accorciare gli intervalli di manutenzione.

## STRUMENTI PER LA MANUTENZIONE E L'ASSEMBLAGGIO DELLE RUOTE

Qui sono elencati gli strumenti necessari per la corretta manutenzione delle ruote OQUO in relazione all'assemblaggio e alla centratura. Consultare la documentazione del produttore per gli strumenti richiesti per la manutenzione del mozzo.

Questo elenco è soggetto a modifiche delle specifiche della ruota che potrebbero richiedere l'uso di altri strumenti non mostrati qui. In caso di dubbi, consultare OQUO.

### 1. DISPOSITIVO PER LA CENTRATURA DELLE RUOTE A DOPPIO LATO

Utilizzare sempre un dispositivo di qualità a doppio lato per la centratura delle ruote, per controllare la centratura e la deviazione delle ruote. Non eseguire questi interventi di verifica e manutenzione con la ruota montata sulla bicicletta. I risultati potrebbero essere imprecisi.

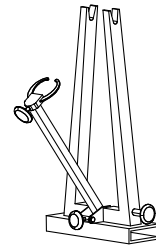

### 2. CHIAVE TIRARAGGI

**Est.:** per la regolazione dei nippli dall'esterno del cerchio. Per la maggior parte dei nippli.

**Int.:** per la regolazione dei nippli dall'interno del cerchio (gola del cerchio). È possibile regolare i nippli Sapim Double Square dall'interno del cerchio, o dal lato esterno, mediante una chiave tiraraggi esterna.

#### AVVISO

Indipendentemente dall'uso di una chiave tiraraggi raggi esterna o interna, questa dovrà essere della dimensione giusta per i nippli, per evitare di danneggiare e/o arrotondare i nippli stessi. È utile avere a disposizione chiavi di diverse misure, testandole sui nippli da regolare, per garantire l'impiego della chiave della dimensione adeguata.

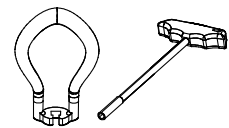

### 3. CHIAVE TIRARAGGI PIATTA

Durante il serraggio di un nipplo, utilizzare uno strumento per bloccare i raggi piatti, per evitare la torsione del raggio.

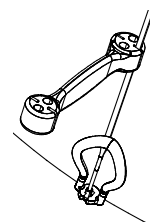

#### 4. TENSIOMETRO

Utilizzare sempre un tensiometro di qualità e verificarne regolarmente la taratura in base alle istruzioni del produttore.

Attenersi alle istruzioni del produttore per un uso adeguato e per interpretare correttamente la lettura dei valori di tensione, in base alle specifiche del produttore.

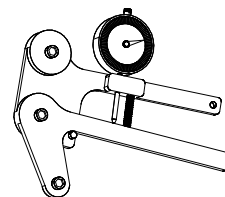

---

#### 5. DIMA PER ALLINEAMENTO

Utilizzare sempre una dima per verificare l'allineamento del cerchio in relazione alle estremità del mozzo in contatto con l'interno del telaio o della forcella.

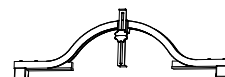

### VERIFICA DELLA TENSIONE DEI RAGGI

Controllare regolarmente la tensione e la condizione dei raggi.

Controllare regolarmente la deviazione laterale (1) e radiale (2), e la campanatura (3) delle ruote su un dispositivo di centraggio ruote. Le verifiche e le regolazioni effettuate con la ruota montata sulla bici potrebbero risultare imprecise.

Qualora fosse necessaria la regolazione di alcuni raggi, usare una chiave tiraraggi delle dimensioni corrette per regolare la tensione dei raggi stessi.

Il metodo per allentare la tensione della ruota è consultabile nella sezione Assemblaggio della ruota del presente manuale. Verificare gli obiettivi di deviazione e tensione per le ruote OQUO, nella sezione Assemblaggio della ruota del presente manuale.

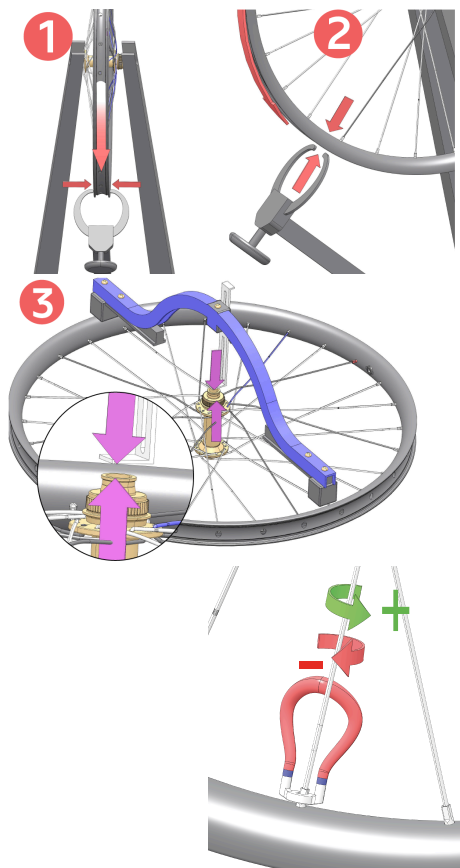

Usare una chiave tiraraggi piatta per bloccare i raggi mantenendoli piatti e impedirne la torsione. I raggi tondi si possono anche bloccare con una pinza liscia, per impedirne la torsione. Evitare di danneggiare i raggi.

Quando si regolano uno o più raggi, verificare nuovamente la deviazione laterale e radiale della ruota e la campanatura. Se si regola la tensione di 4 o più raggi, allentare la tensione della ruota e verificarne la centratura.

## SOSTITUZIONE DI UN RAGGIO

I raggi rotti, piegati o danneggiati vanno sostituiti al più presto.

Per sostituire un raggio, rimuovere lo pneumatico e il nastro del cerchio dalla ruota.

Per la sostituzione di un raggio, potrebbe essere necessario rimuovere il disco del freno e anche la cassetta pignoni nel caso delle ruote posteriori.



Utilizzare una chiave tiraraggi per rimuovere il nipplo (1, 2)

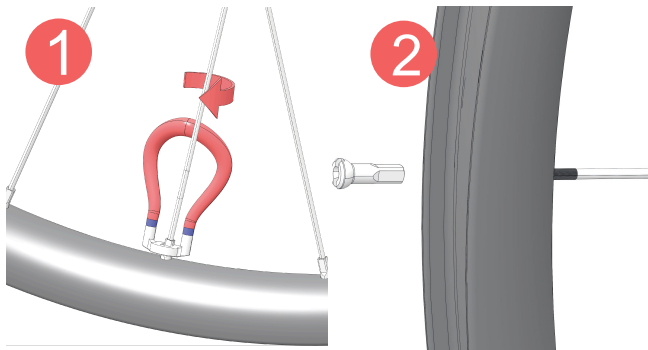

Rimuovere il raggio dal mozzo (3). Se il raggio è rotto, sarà possibile rimuoverlo assieme al nipplo e smontare il segmento del mozzo separatamente (4).

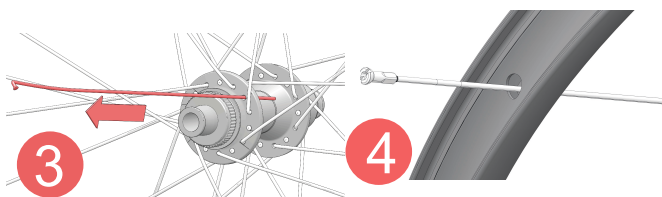

Installare il nuovo raggio dal lato mozzo e nella stessa posizione del raggio originale.

Consultare la sezione Raggiatura del capitolo Assemblaggio della ruota nel presente manuale per una guida sul posizionamento dei raggi con le diverse raggiature. Consultare la tabella delle specifiche tecniche presente in questo manuale per verificare il modello e la lunghezza del raggio delle proprie ruote OQUO.

Utilizzare un dispositivo di centratura e gli strumenti adeguati per il tensionamento del nuovo raggio. Dopo il montaggio, verificare che la tensione del raggio, la deviazione laterale e radiale, e la campanatura della ruota corrispondano ai valori corretti.

Potrebbe rendersi necessario regolare vari raggi oltre a quello sostituito. Se è necessario regolare più raggi, allentare la tensione della ruota come indicato alla sezione Assemblaggio della ruota del presente manuale e verificare che i valori di allineamento, tensione e deviazione rientrino nelle tolleranze.

Installare nuovamente il nastro del cerchio, lo pneumatico e la cassetta, se è stato necessario rimuoverli.

---

## MANUTENZIONE MOZZO

### MANUTENZIONE MOZZO

Fare riferimento alla tabella delle specifiche tecniche della ruota OQUO nel presente manuale per verificare quale modello di mozzo viene montato sul proprio modello di ruota.

Le informazioni contenute nel presente manuale e nei manuali di altri produttori a cui si fa riferimento sono principalmente destinate ai distributori OQUO e di altri produttori di componenti e agli utenti con esperienza nella manutenzione delle ruote.

Se un utente non dispone delle conoscenze e competenze per eseguire le procedure di manutenzione descritte nel presente manuale tecnico o per montare i ricambi elencati, le riparazioni e la manutenzione delle ruote dovranno essere affidate a un rivenditore OQUO.

Le informazioni di contatto dei distributori sono disponibili sul nostro sito web [www.oquowheels.com](http://www.oquowheels.com)

#### AVVISO

---

I danni causati da operazioni di manutenzione o riparazione inadeguate non sono coperti dalle condizioni di garanzia.



---

Interventi errati di riparazione, manutenzione o montaggio dei componenti possono avere effetti negativi su integrità e funzionamento delle ruote, e causare incidenti con lesioni gravi o letali.

### MOZZI DT SWISS MTB & OQUO DT INSIDE

Vedere la pagina seguente per i link ai manuali dei mozzi DT Swiss MTB sul sito web del produttore:

#### AVVISO

---

I mozzi Oquo DT Inside sono realizzati con gli stessi componenti dei mozzi equivalenti DT Swiss (eccetto il corpo del mozzo), pertanto le procedure di manutenzione sono le stesse previste per i mozzi equivalenti DT Swiss.

MODELLO MOZZO	TIPO MANUALE/ NOME	CONTENUTI	LINK AL DOCUMENTO
Tutti i mozzi Oquo DT Inside e DT Swiss	Manuale d'uso MANUALE D'USO MOZZI TUTTI I MOZZI	<ul style="list-style-type: none"> <li>• Informazioni generali</li> <li>• Avvertenze per l'uso</li> <li>• Montaggio</li> <li>• Manutenzione e cura</li> </ul>	<a href="https://www.dtswiss.com/pmt/00/00/00/00/00/00/10/00/00/00/86/2/MAN_HXWXXXXXX1610S_WEB_ZZ_001.pdf">https://www.dtswiss.com/pmt/00/00/00/00/00/00/10/00/00/00/86/2/MAN_HXWXXXXXX1610S_WEB_ZZ_001.pdf</a>
Mozzi anteriori Oquo DT Inside e DT Swiss	Manuale tecnico/ MANUALE TECNICO MOZZI ANT.	<ul style="list-style-type: none"> <li>• Smontaggio, pulizia e sostituzione dei cuscinetti e dell'asse</li> <li>• Utensili, componenti e materiali necessari</li> </ul>	<a href="https://d2a13k6araex7u.cloudfront.net/pmt/00/00/00/00/00/00/10/00/00/05/56/2/MAN_HXD10000005562S_WEB_EN_001.pdf">https://d2a13k6araex7u.cloudfront.net/pmt/00/00/00/00/00/00/10/00/00/05/56/2/MAN_HXD10000005562S_WEB_EN_001.pdf</a>
Mozzo posteriore Oquo LTD DT Inside e DT Swiss 240	Manuale tecnico/ MANUALE TECNICO MOZZI RATCHET EXP	<ul style="list-style-type: none"> <li>• Smontaggio, pulizia e sostituzione di tutte le parti del mozzo</li> <li>• Utensili, componenti e materiali necessari</li> </ul>	<a href="https://www.dtswiss.com/pmt/00/00/00/00/00/00/10/00/00/03/11/1/MAN_HXD10000003111S_WEB_EN_001.pdf">https://www.dtswiss.com/pmt/00/00/00/00/00/00/10/00/00/03/11/1/MAN_HXD10000003111S_WEB_EN_001.pdf</a>
	Manuale manutenzione corpetto MANUTENZIONE CORPETTO RUOTA LIBERA RATCHET EXP	<ul style="list-style-type: none"> <li>• Smontaggio, pulizia e sostituzione del sistema Ratchet Exp</li> <li>• Utensili, componenti e materiali necessari</li> </ul>	<a href="https://www.dtswiss.com/pmt/00/00/00/00/00/00/10/00/00/04/19/3/MAN_HXD10000004193S_XXX_EN_001.pdf">https://www.dtswiss.com/pmt/00/00/00/00/00/00/10/00/00/04/19/3/MAN_HXD10000004193S_XXX_EN_001.pdf</a>
	Manuale sostituzione da EXP 36D a EXP 54D CONVERSIONE MOZZI RATCHET EXP DA 36 A 54	<ul style="list-style-type: none"> <li>• Sostituzione del sistema Ratchet EXP 36D con il sistema EXP 54D</li> <li>• Utensili, componenti e materiali necessari</li> </ul>	<a href="https://www.dtswiss.com/pmt/00/00/00/00/00/00/10/00/00/03/77/3/MAN_HXD10000003773S_WEB_EN_001.pdf">https://www.dtswiss.com/pmt/00/00/00/00/00/00/10/00/00/03/77/3/MAN_HXD10000003773S_WEB_EN_001.pdf</a>
Mozzo posteriore Oquo LTD DT Inside e DT Swiss 350 DEG 72	Tutto sul mozzo 350 DEG / Pagina Assistenza DT Swiss	<ul style="list-style-type: none"> <li>• Ricambi</li> <li>• Manuali</li> <li>• Video</li> </ul>	<a href="https://www.dtswiss.com/en/support/product-support?matnr=H350TDDRR32SA5051S">https://www.dtswiss.com/en/support/product-support?matnr=H350TDDRR32SA5051S</a>
	Manuale Tecnico/ MOZZI RATCHET DEG	<ul style="list-style-type: none"> <li>• Smontaggio, pulizia e sostituzione di tutte le parti del mozzo</li> <li>• Utensili, componenti e materiali necessari</li> </ul>	<a href="https://d2a13k6araex7u.cloudfront.net/pmt/00/00/00/00/00/00/10/00/00/05/10/4/MAN_HXD10000005104S_WEB_EN_001.pdf">https://d2a13k6araex7u.cloudfront.net/pmt/00/00/00/00/00/00/10/00/00/05/10/4/MAN_HXD10000005104S_WEB_EN_001.pdf</a>
	Video/ 350 DEG COMPLETE SERVICE	<ul style="list-style-type: none"> <li>• Smontaggio, pulizia e sostituzione di tutte le parti del mozzo</li> <li>• Utensili, componenti e materiali necessari</li> </ul>	<a href="https://www.youtube.com/watch?v=UMLquGPw2Jg">https://www.youtube.com/watch?v=UMLquGPw2Jg</a>
Mozzo posteriore Oquo Team DT Inside E DT Swiss 350	Manuale tecnico MANUALE TECNICO MOZZI RATCHET	<ul style="list-style-type: none"> <li>• Smontaggio, pulizia e sostituzione di tutte le parti del mozzo</li> <li>• Utensili, componenti e materiali necessari</li> </ul>	<a href="https://www.dtswiss.com/pmt/00/00/00/00/00/00/10/00/00/00/89/6/MAN_WXD10000000896S_WEB_EN_001.pdf">https://www.dtswiss.com/pmt/00/00/00/00/00/00/10/00/00/00/89/6/MAN_WXD10000000896S_WEB_EN_001.pdf</a>
Mozzo posteriore DT Swiss 350 Hybrid	Manuale tecnico MANUALE TECNICO MOZZI RATCHET	<ul style="list-style-type: none"> <li>• Smontaggio, pulizia e sostituzione di tutte le parti del mozzo</li> <li>• Utensili, componenti e materiali necessari</li> </ul>	<a href="https://www.dtswiss.com/pmt/00/00/00/00/00/00/10/00/00/00/89/6/MAN_WXD10000000896S_WEB_EN_001.pdf">https://www.dtswiss.com/pmt/00/00/00/00/00/00/10/00/00/00/89/6/MAN_WXD10000000896S_WEB_EN_001.pdf</a>
Mozzo posteriore DT Swiss 370	Manuale tecnico MANUALE TECNICO MOZZI RATCHET LN	<ul style="list-style-type: none"> <li>• Smontaggio, pulizia e sostituzione di tutte le parti del mozzo</li> <li>• Utensili, componenti e materiali necessari</li> </ul>	<a href="https://www.dtswiss.com/pmt/00/00/00/00/00/00/10/00/00/03/77/4/MAN_HXD10000003774S_WEB_EN_001.pdf">https://www.dtswiss.com/pmt/00/00/00/00/00/00/10/00/00/03/77/4/MAN_HXD10000003774S_WEB_EN_001.pdf</a>

## RICAMBI

### RICAMBI MOZZI OQUO DT SWISS INSIDE

Consultare la tabella delle specifiche tecniche delle ruote OQUO per il modello di mozzo delle proprie ruote.

#### MOZZI ANTERIORI OQUO DT SWISS INSIDE

##### Oquo LTD DT Swiss 240 Inside Straight Pull 15x110 24H Centerlock

Consultare la tabella delle specifiche tecniche delle ruote OQUO per il modello di mozzo delle proprie ruote.

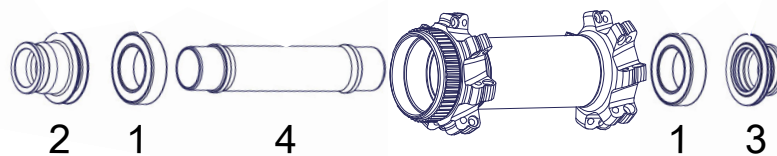

	DESCRIZIONE	NUMERO PER MOZZO	N. ARTICOLO DT DT SWISS	N. ARTICOLO ORBEA
1	CUSCINETTI 1728 ESB/ESNB L	2	HSBXXX00N9115S	<a href="#">XB68</a>
2	Adattatore ant. FW ADAPT WP XXX/15 L BM DISC	1	HWAXXX00S2760S	<a href="#">XB69</a>
3	Adattat. ant. RUOTA ANT. ADAPT WP XXX/15 R BM DISC	1	HWAXXX00S2761S	<a href="#">XB70</a>
4	ASSE ANTERIORE AL 110 mm diam 17/64,3 mm	1	HRCXXX00N3296S	<a href="#">XB71</a>

	DESCRIZIONE	N. ARTICOLO DT DT SWISS	N. ARTICOLO ORBEA
<b>Composto per il montaggio</b>	Grasso universale DT Swiss 20 g	HXTXXX00NMG20S	<a href="#">XB72</a>
<b>Strumenti</b>	Cilindro di montaggio Ø17 / 28 mm x 40 mm	HXTXXX00N9345S	<a href="#">XB73</a>
	Utensile asse Ø17 mm	HXTXXX00N5067S	<a href="#">XB74</a>

Cliccare sul codice ricambio per acquistare online. I ricambi per i mozzi sono disponibili esclusivamente per i rivenditori Orbea attraverso Kide (accesso B2B)

**MOZZI ANTERIORI OQUO DT SWISS INSIDE****Oquo TEAM DT Swiss 350 Inside Straight Pull 15x110 28H Centerlock/6 bulloni**

Consultare la tabella delle specifiche tecniche delle ruote OQUO per il modello di mozzo delle proprie ruote.

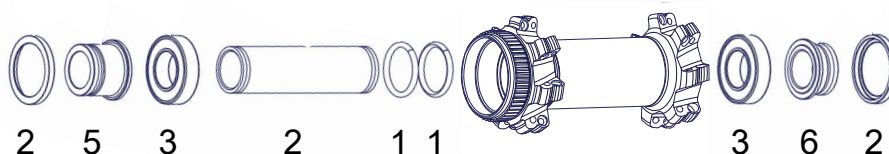

	DESCRIZIONE	NUMERO PER MOZZO	N. ARTICOLO DT SWISS	N. ARTICOLO ORBEA
1	O-RING diam 18X2,5 mm NBR 70 SHORE ISO3601	2	HSOXXX00X2164S	XC04
2	COPERTURA ASSE PASS. ANT. 15 mm	2	HCD00100S4603S	XC05
3	CUSCINETTI 6902 ESB/ESNB L	2	HSBXXX00N2336S	XC06
4	DISTANZIALE diam. 15 mm x 67,2 mm	1	HXD00000N6567C	XC07
5	ADATT. ANT. SP XXX/15 L B	1	HCA00100S7745S	XC08
6	ADATT. ANT. ADAPT SP XXX/15 R B	1	HCA00100S7744S	XC09

	DESCRIZIONE	N. ARTICOLO DT SWISS	N. ARTICOLO ORBEA
<b>Composto per il montaggio</b>	Grasso universale DT Swiss 20 g	HXTXXX00NMG20S	XB72
<b>Strumenti</b>	Set strumenti 350 15mm	HWTXXX00N5290S	XC10
	Strumento di montaggio	HXTXXX00N9793S	XC11

Cliccare sul codice ricambio per acquistare online. I ricambi per i mozzi sono disponibili esclusivamente per i rivenditori Orbea attraverso Kide (accesso B2B)

**MOZZI ANTERIORI OQUO DT SWISS INSIDE****Oquo LTD DT Swiss 350 Inside J-bend 15x110 28H 6 bulloni**

Consultare la tabella delle specifiche tecniche delle ruote OQUO per il modello di mozzo delle proprie ruote.

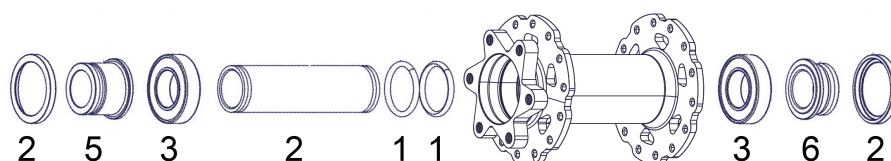

	DESCRIZIONE	NUMERO PER MOZZO	N. ARTICOLO DT SWISS	N. ARTICOLO ORBEA
1	O-RING diam 18X2,5 mm NBR 70 SHORE ISO3601	2	HSOXXX00X2164S	XC04
2	COPERTURA ASSE PASS. ANT. 15 mm	2	HCD00100S4603S	XC05
3	CUSCINETTI 6902 ESB/ESNB L	2	HSBXXX00N2336S	XC06
4	DISTANZIALE diam. 15 mm x 67,2 mm	1	HXD00000N6567C	XC07
5	ADATT. ANT. SP XXX/15 L B	1	HCA00100S7745S	XC08
6	ADATT. ANT. ADAPT SP XXX/15 R B	1	HCA00100S7744S	XC09

	DESCRIZIONE	N. ARTICOLO DT SWISS	N. ARTICOLO ORBEA
<b>Composto per il montaggio</b>	Grasso universale DT Swiss 20 g	HXTXXX00NMG20S	XB72
<b>Strumenti</b>	Set strumenti 350 15mm	HWTXXX00N5290S	XC10
	Strumento di montaggio	HXTXXX00N9793S	XC11

Cliccare sul codice ricambio per acquistare online. I ricambi per i mozzi sono disponibili esclusivamente per i rivenditori Orbea attraverso Kide (accesso B2B)

## MOZZI POSTERIORI OQUO DT SWISS INSIDE

### Oquo LTD DT Swiss 240 Inside Straight Pull 12x148 28H Centerlock

Consultare la tabella delle specifiche tecniche delle ruote OQUO per il modello di mozzo delle proprie ruote.

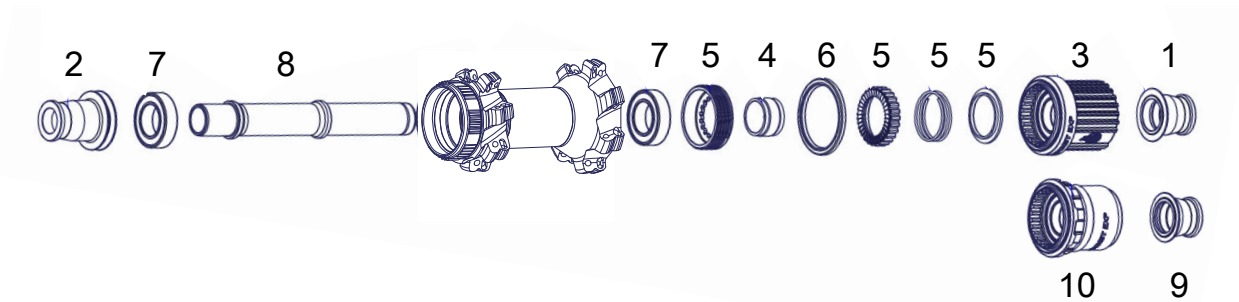

	DESCRIZIONE	NUMERO PER MOZZO	N. ARTICOLO DT SWISS	N. ARTICOLO ORBEA
1	Adattatore RW ADAPT WP XXX/12 R BM MS	1	HWAXXX00S2766S	<a href="#">XB87</a>
2	ADATT. POST. WP XXX/12 L BM	1	HWAXXX00S2763S	<a href="#">XB88</a>
3	FB W MTB SHI MS EXP AL LI SL M	1	HWRABL00S4863S	<a href="#">XB89</a>
4	DISTANZIALE LEGA 10,7 EXP	1	HRDXXX00N8242S	<a href="#">XB90</a>
5	KIT MANUTENZIONE RATCHET 36D EXP SENZA UTENSILE	1	HWYXXX00N0042S	<a href="#">XB91</a>
6	GUARNIZIONE MOZZO/ROTORE (diam. 30x36x2,5 mm)	1	HSOXXX00N1031S	<a href="#">XB92</a>
7	CUSCINETTO 1526 ESB/ESNB L	2	HSBXXX00N3741S	<a href="#">XB93</a>
8	ASSE POSTERIORE AL XXX mm diam 15/52,85 mm EXP	1	HCCXXX00S3303S	<a href="#">XB94</a>
9	Adattatore posteriore RW ADAPT WP XXX/12 R BM SRAM XD	1	HWAXXX00S2767S	<a href="#">XB95</a>
10	FB W MTB SRA XD EXP AL ST SL M	1	HWRABL00S3830S	<a href="#">XB96</a>

	DESCRIZIONE	N. ARTICOLO DT SWISS	N. ARTICOLO ORBEA
<b>Composto per il montaggio</b>	Grasso universale DT Swiss 20 g	HXTXXX00NMG20S	<a href="#">XB72</a>
	Grasso speciale DT Swiss 20 g	HXT10032508S	<a href="#">XB97</a>
<b>Strumenti</b>	Cilindro di montaggio 15x26x40 mm	HWTXXX00N5290S	<a href="#">XB98</a>
	Strumento di montaggio/smontaggio per cricchetto filettato	HXTXXX00N9793S	<a href="#">XB99</a>
	Strumento di montaggio/smontaggio cuscinetto a sfera drive side (dx)	HWTXXX00N5290S	<a href="#">XC01</a>
	Strumento di montaggio guarnizione mozzo	HXTXXX00N9793S	<a href="#">XC02</a>

Cliccare sul codice ricambio per acquistare online. I ricambi per i mozzi sono disponibili esclusivamente per i rivenditori Orbea attraverso Kide (accesso B2B)

**MOZZI POSTERIORI OQUO DT SWISS INSIDE****Oquo LTD DT Swiss 350 Inside Straight Pull 12x148 28/32H Centerlock/6 bulloni**

Consultare la tabella delle specifiche tecniche delle ruote OQUO per il modello di mozzo delle proprie ruote.

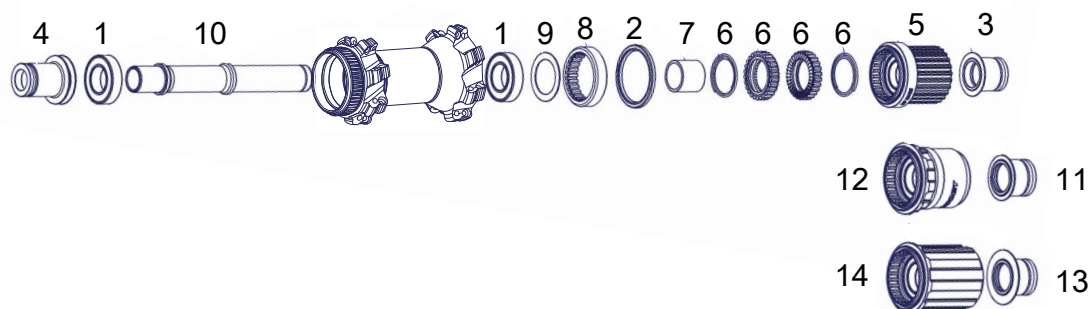

	DESCRIZIONE	NUMERO PER MOZZO	N. ARTICOLO DT SWISS	N. ARTICOLO ORBEA
1	CUSCINETTI 6902 ESB/ESNB L	2	HSBXXX00N2336S	XC06
2	GUARNIZIONE MOZZO/ROTORE (diam. 30x36x2,5 mm)	1	HSOXXX00N1031S	XB92
3	ADATT. POST. WP XXX/12 R B MS	1	HWA00100S7912S	XC15
4	ADATT. POST. WP XXX/12 L B	1	HWA00100S7841S	XC17
5	FB W MTB SHI MS RAT AL LI SL B	1	HWRABL00S2148S	XC19
6	KIT MANUTENZIONE RATCHET 36D SL	1	HWTXXX00NSK36S	XC20
7	DISTANZIALE LEGA 15,4 mm BL	1	HCDXXX00S1077S	XC21
8	DADO A GHIERA ACCIAIO M34X1 240	1	HXDXXX00N1131S	XC22
9	ANELLO SPESSORE diam. 28/20X0,5 mm	1	HCDXXX00S1083S	XC23
10	ASSE POSTERIORE AL 148 mm diam. 15/48,2 mm	1	HCCXXX00S6450S	XC24
11	ADATT. POST. WP XXX/12 R B SRAM XD	1	HWA00100S7513S	XC25
12	FB W MTB SRA XD RAT AL ST SL B	1	HWRAAL00S3114S	XC26
13	ADATT. POST. WP XXX/12 R B	1	HWA00100S7892S	XC27
14	FB W MTB SHI RAT AL LI SL B	1	HWRABL00S1239S	XC28

	DESCRIZIONE	N. ARTICOLO DT SWISS	N. ARTICOLO ORBEA
<b>Composto per il montaggio</b>	Grasso universale DT Swiss 20 g	HXTXXX00NMG20S	XB72
	Grasso speciale DT Swiss 20 g	HXT10032508S	XB97
<b>Strumenti</b>	Cilindro di montaggio 15x26x40 mm	HWTXXX00N5290S	XB98
	Strumento di montaggio guarnizione mozzo	HXTXXX00N1000S	XC02
	Utensile per ghiera	HXTXXX00N5027S	XC32

Cliccare sul codice ricambio per acquistare online. I ricambi per i mozzi sono disponibili esclusivamente per i rivenditori Orbea attraverso Kide (accesso B2B)

**MOZZI POSTERIORI OQUO DT SWISS INSIDE****Oquo LTD DT Swiss Inside 350 DEG J-bend 12x148 32H 6 bulloni**

Consultare la tabella delle specifiche tecniche delle ruote OQUO per il modello di mozzo delle proprie ruote.

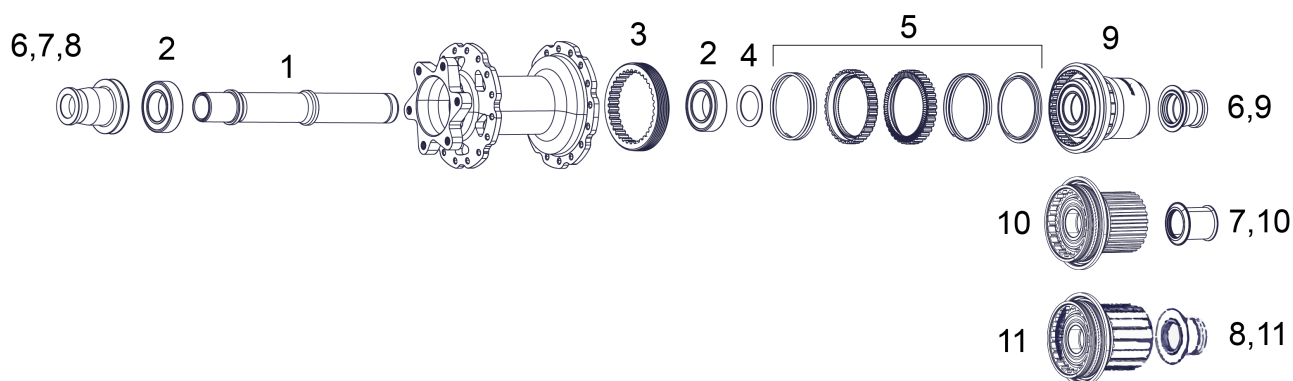

	DESCRIZIONE	NUMERO PER MOZZO	N. ARTICOLO DT SWISS	N. ARTICOLO ORBEA
1	ASSE POSTERIORE AL 148 mm diam. 15/ 48,2 mm	1	HCCXXX00S6450S	<a href="#">XC24</a>
2	CUSCINETTI 6902 ESB/ESNB L	2	HSBXXX00N2336S	<a href="#">XC06</a>
3	GHIERA ST M45X2-2MM DEG	1	HXDXXX00N9037S	<a href="#">XJ88</a>
4	DISTANZIALE LEGA 2,95 mm N	1	HCD14200N9313S	<a href="#">XJ89</a>
5	KIT MANUTENZIONE RATCHET 72T DEG	1	HWYXXX00N6599S	<a href="#">XJ90</a>
6	KIT ADATT. RUOTA POST. 142/Ø12 240 SRAM XD (SOLO TAPPI)	1	HWGXXX00S3188S	<a href="#">X649</a>
7	KIT ADATT. RUOTA POST. XXX/12 B MS (SOLO TAPPI)	1	HWGXXX00S5643S	<a href="#">X647</a>
8	KIT CONVERSIONE X12 HG (SOLO TAPPI)	1	HWGXXX0002193C	<a href="#">X648</a>
9	FB K MTB SRA XD DEG 12/148 AL ST SL B	1	HWYABL00S2779S	<a href="#">XJ91</a>
10	FB K MTB SHI MS DEG 12/148 AL ST SL B	1	HWYABL00S2787S	<a href="#">XJ92</a>
11	FB K MTB SHI DEG 12/148 AL ST SL B	1	HWYABL00S2786S	<a href="#">XJ93</a>

	DESCRIZIONE	N. ARTICOLO DT SWISS	N. ARTICOLO ORBEA
<b>Composto per il montaggio</b>	Grasso universale DT Swiss 20 g	HXTXXX00NMG20S	<a href="#">XB72</a>
	Grasso speciale DT Swiss 20 g	HXT10032508S	<a href="#">XB97</a>
<b>Strumenti</b>	Cilindro di montaggio 15x26x40 mm	HWTXXX00N5290S	<a href="#">XB98</a>
	Diametro cil. installazione 15 / 28 x 35 mm	HXTXXX00N5024S	<a href="#">XC02</a>
	utensile per ghiera DEG	HXTXXX00N2612S	—

Clickare sul codice ricambio per acquistare online. I ricambi per i mozzi sono disponibili esclusivamente per i rivenditori Orbea attraverso Kide (accesso B2B)

**MOZZI POSTERIORI OQUO DT SWISS INSIDE****RICAMBI PER MOZZI DT SWISS**

Consultare la tabella delle specifiche tecniche delle ruote OQUO per il modello di mozzo delle proprie ruote.

**MOZZI ANTERIORI DT SWISS****DT Swiss 240 J-bend 15x110 24/28H Centerlock/6-bulloni**

Consultare la tabella delle specifiche tecniche delle ruote OQUO per il modello di mozzo delle proprie ruote.

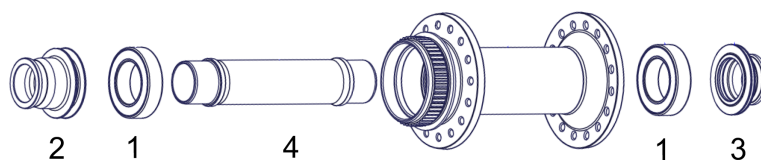

	DESCRIZIONE	NUMERO PER MOZZO	N. ARTICOLO DT DT SWISS	N. ARTICOLO ORBEA
1	CUSCINETTI 1728 ESB/ESNB L	2	HSBXXX00N9115S	<b>XB68</b>
2	Adattatore ant. FW ADAPT WP XXX/15 L BM DISC	1	HWAXXX00S2760S	<b>XB69</b>
3	Adattat. ant. RUOTA ANT. ADAPT WP XXX/15 R BM DISC	1	HWAXXX00S2761S	<b>XB70</b>
4	ASSE ANTERIORE AL 110 mm diam 17/64,3 mm	1	HRCXXX00N3296S	<b>XB71</b>

	DESCRIZIONE	N. ARTICOLO DT SWISS	N. ARTICOLO ORBEA
<b>Composto per il montaggio</b>	Grasso universale DT Swiss 20 g	HXTXXX00NMG20S	<b>XB72</b>
<b>Strumenti</b>	Cilindro di montaggio Ø17 / 28 mm x 40 mm	HXTXXX00N9345S	<b>XB73</b>
	Utensile asse Ø17 mm	HXTXXX00N5067S	<b>XB74</b>

Cliccare sul codice ricambio per acquistare online. I ricambi per i mozzi sono disponibili esclusivamente per i rivenditori Orbea attraverso Kide (accesso B2B)

**MOZZI ANTERIORI DT SWISS****DT Swiss 350 J-bend 15x110 28H Centerlock/6-bulloni**

Consultare la tabella delle specifiche tecniche delle ruote OQUO per il modello di mozzo delle proprie ruote.

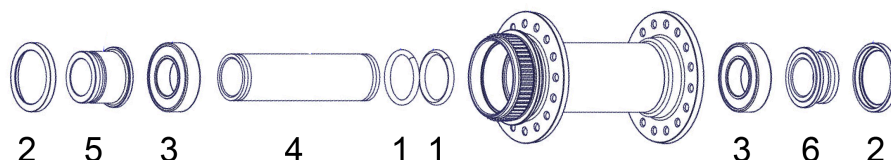

	DESCRIZIONE	NUMERO PER MOZZO	N. ARTICOLO DT SWISS	N. ARTICOLO ORBEA
1	O-RING diam 18X2,5 mm NBR 70 SHORE ISO3601	2	HSOXXX00X2164S	XC04
2	COPERTURA ASSE PASS. ANT. 15 mm	2	HCD00100S4603S	XC05
3	CUSCINETTI 6902 ESB/ESNB L	2	HSBXXX00N2336S	XC06
4	DISTANZIALE diam. 15 mm x 67,2 mm	1	HXD00000N6567C	XC07
5	ADATT. ANT. SP XXX/15 L B	1	HCA00100S7745S	XC08
6	ADATT. ANT. ADAPT SP XXX/15 R B	1	HCA00100S7744S	XC09

	DESCRIZIONE	N. ARTICOLO DT SWISS	N. ARTICOLO ORBEA
<b>Composto per il montaggio</b>	Grasso universale DT Swiss 20 g	HXTXXX00NMG20S	XB72
<b>Strumenti</b>	Set strumenti 350 15mm	HWTXXX00N5290S	XC10
	Strumento di montaggio	HXTXXX00N9793S	XC11

Cliccare sul codice ricambio per acquistare online. I ricambi per i mozzi sono disponibili esclusivamente per i rivenditori Orbea attraverso Kide (accesso B2B)

**MOZZI ANTERIORI DT SWISS****DT Swiss 350 J-bend 20x110 28H 6-bulloni**

Consultare la tabella delle specifiche tecniche delle ruote OQUO per il modello di mozzo delle proprie ruote.

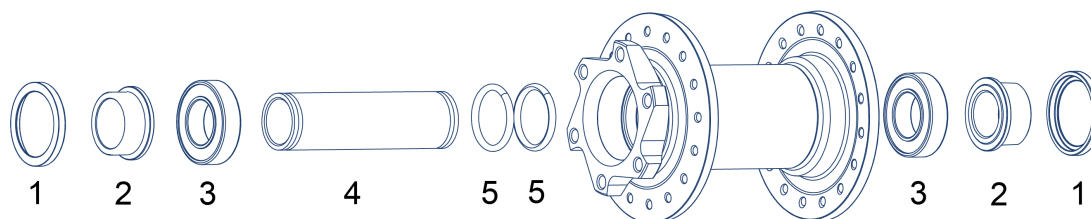

	DESCRIZIONE	NUMERO PER MOZZO	N. ARTICOLO DT SWISS	N. ARTICOLO ORBEA
1	FW COVER FOR TA20mm	2	HCDXXX00S1461S	XJ95
2	FW ADAPT SP 110X DBIS TA20 B	2	HCAXXX00S6824S	XJ96
3	CUSCINETTI 6904 ESB/ESNB L	2	HSBXXX00N1414S	XJ97
4	DISTANZIALE ANT. 65,1x25 mm	1	HDXXXX00N6823S	XJ98
5	O-RING diam 18X2,5 mm NBR 70 SHORE ISO3601	2	HSOXXX00X2164S	XC04

	DESCRIZIONE	N. ARTICOLO DT SWISS	N. ARTICOLO ORBEA
<b>Composto per il montaggio</b>	Grasso universale DT Swiss 20 g	HXTXXX00NMG20S	XB72
<b>Strumenti</b>	Set strumenti 350 20 mm	HWTXXX00N5292S	—
	Strumento di montaggio	HXTXXX00N9793S	XC11

Cliccare sul codice ricambio per acquistare online. I ricambi per i mozzi sono disponibili esclusivamente per i rivenditori Orbea attraverso Kide (accesso B2B)

**MOZZI ANTERIORI DT SWISS****DT Swiss 370 J-bend 15x110 28H 6 bulloni**

Consultare la tabella delle specifiche tecniche delle ruote OQUO per il modello di mozzo delle proprie ruote.

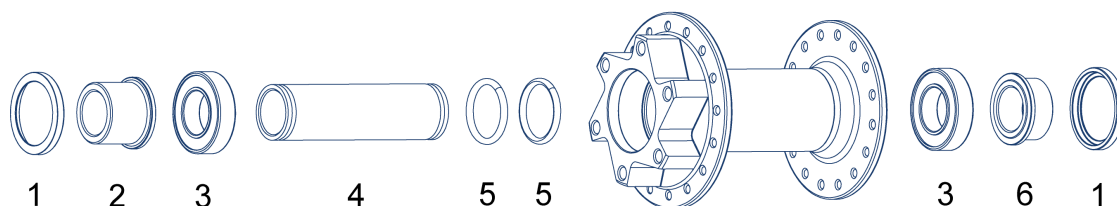

	DESCRIZIONE	NUMERO PER MOZZO	N. ARTICOLO DT SWISS	N. ARTICOLO ORBEA
1	COPERTURA ANT. PER TA15 mm	2	HCD00100S4603S	XC05
2	ADATT. ANT. SP 100L DBCL SA15 S	1	HCA00100S4601S	XC48
3	CUSCINETTI 6902 ESB/ESNB L	2	HSBXXX00N2336S	XC06
4	DISTANZIALE Ø 15 mm x 67,2 mm	1	HXD00000N6567C	XC07
5	O-RING Ø18X2,5 MM NBR 70 SHORE ISO3601	2	HSOXXX00X2164S	XC04
6	ADATT. ANT.T SP 100R DBCL SA15 S	1	HCA00100S4602S	XC47

	DESCRIZIONE	N. ARTICOLO DT SWISS	N. ARTICOLO ORBEA
<b>Composto per il montaggio</b>	Grasso universale DT Swiss 20 g	HXTXXX00NMG20S	XB72
<b>Strumenti</b>	Set strumenti 350 15mm	HWTXXX00N5290S	XC10
	Strumento di montaggio	HXTXXX00N9793S	XC11

Clickare sul codice ricambio per acquistare online. I ricambi per i mozzi sono disponibili esclusivamente per i rivenditori Orbea attraverso Kide (accesso B2B)

**MOZZI ANTERIORI DT SWISS****DT Swiss 350 Hybrid J-bend 15x110 32H 6-bulloni (fino a MY2023)**

Consultare la tabella delle specifiche tecniche delle ruote OQUO per il modello di mozzo delle proprie ruote.

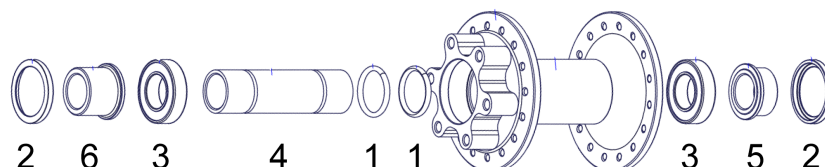

	DESCRIZIONE	NUMERO PER MOZZO	N. ARTICOLO DT SWISS	N. ARTICOLO ORBEA
1	O-RING diam 18X2,5 mm NBR 70 SHORE ISO3601	2	HSOXXX00X2164S	XC04
2	COPERTURA ASSE PASS. ANT. 15 mm	2	HCD00100S4603S	XC05
3	CUSCINETTI 6902 ESB/ESNB L	2	HSBXXX00N2336S	XC06
4	DISTANZIALE Ø 15 mm x 67,2 mm	1	HXD00000N6449S	XC46
5	ADATT. ANT.T SP 100R DBCL SA15 S	1	HCA00100S4602S	XC47
6	ADATT. ANT. SP 100L DBCL SA15 S	1	HCA00100S4601S	XC48

	DESCRIZIONE	N. ARTICOLO DT SWISS	N. ARTICOLO ORBEA
<b>Composto per il montaggio</b>	Grasso universale DT Swiss 20 g	HXTXXX00NMG20S	XB72
<b>Strumenti</b>	Set strumenti 350 15mm	HWTXXX00N5290S	XC10
	Strumento di montaggio	HXTXXX00N9793S	XC11

Clickare sul codice ricambio per acquistare online. I ricambi per i mozzi sono disponibili esclusivamente per i rivenditori Orbea attraverso Kide (accesso B2B)

**MOZZI ANTERIORI DT SWISS****DT Swiss 350 Hybrid J-bend 15x110 28H 6-bulloni (da MY2024)**

Consultare la tabella delle specifiche tecniche delle ruote OQUO per il modello di mozzo delle proprie ruote.

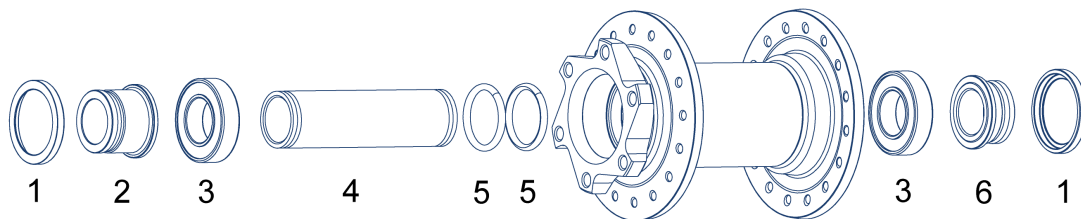

	DESCRIZIONE	NUMERO PER MOZZO	N. ARTICOLO DT SWISS	N. ARTICOLO ORBEA
1	COPERTURA ASSE PASS. ANT. 15 mm	2	HCD00100S4603S	XC05
2	ADATT. ANT. SP XXX/15 L B	1	HCA00100S7745S	XC08
3	CUSCINETTI 6902 ESB/ESNB L	2	HSBXXX00N2336S	XC06
4	DISTANZIALE Ø 15 mm x 67,2 mm	1	HXD00000N6567C	XC07
5	O-RING diam 18X2,5 mm NBR 70 SHORE ISO3601	2	HSOXXX00X2164S	XC04
6	ADATT. ANT. ADAPT SP XXX/15 R B	1	HCA00100S7744S	XC09

	DESCRIZIONE	N. ARTICOLO DT SWISS	N. ARTICOLO ORBEA
<b>Composto per il montaggio</b>	Grasso universale DT Swiss 20 g	HXTXXX00NMG20S	XB72
<b>Strumenti</b>	Set strumenti 350 15mm	HWTXXX00N5290S	XC10
	Strumento di montaggio	HXTXXX00N9793S	XC11

Cliccare sul codice ricambio per acquistare online. I ricambi per i mozzi sono disponibili esclusivamente per i rivenditori Orbea attraverso Kide (accesso B2B)

## MOZZI POSTERIORI DT SWISS

## DT Swiss 240 J-bend 12x148 28H Centerlock

Consultare la tabella delle specifiche tecniche delle ruote OQUO per il modello di mozzo delle proprie ruote.

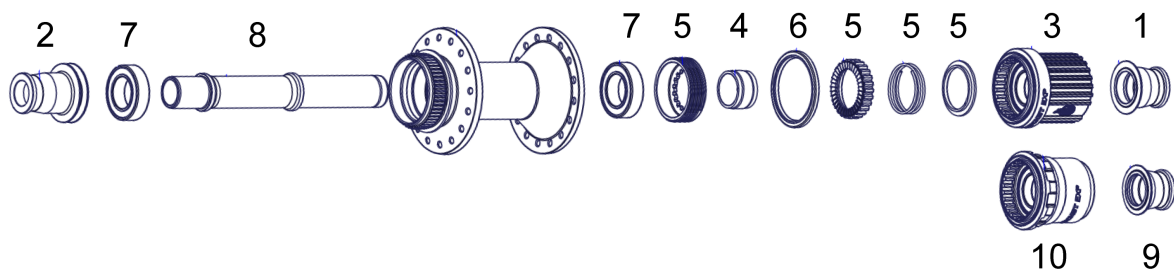

	DESCRIZIONE	NUMERO PER MOZZO	N. ARTICOLO DT SWISS	N. ARTICOLO ORBEA
1	Adattatore RW ADAPT WP XXX/12 R BM MS	1	HWAXXX00S2766S	<a href="#">XB87</a>
2	ADATT. POST. WP XXX/12 L BM	1	HWAXXX00S2763S	<a href="#">XB88</a>
3	FB W MTB SHI MS EXP AL LI SL M	1	HWRABL00S4863S	<a href="#">XB89</a>
4	DISTANZIALE LEGA 10,7 EXP	1	HRDXXX00N8242S	<a href="#">XB90</a>
5	KIT MANUTENZIONE RATCHET 36D EXP SENZA UTENSILE	1	HWYXXX00N0042S	<a href="#">XB91</a>
6	GUARNIZIONE MOZZO/ROTORE (diam. 30x36x2,5 mm)	1	HSOXXX00N1031S	<a href="#">XB92</a>
7	CUSCINETTO 1526 ESB/ESNB L	2	HSBXXX00N3741S	<a href="#">XB93</a>
8	ASSE POSTERIORE AL XXX mm diam 15/52,85 mm EXP	1	HCCXXX00S3303S	<a href="#">XB94</a>
9	Adattatore posteriore RW ADAPT WP XXX/12 R BM SRAM XD	1	HWAXXX00S2767S	<a href="#">XB95</a>
10	FB W MTB SRA XD EXP AL ST SL M	1	HWRABL00S3830S	<a href="#">XB96</a>

	DESCRIZIONE	N. ARTICOLO DT SWISS	N. ARTICOLO ORBEA
<b>Composto per il montaggio</b>	Grasso universale DT Swiss 20 g	HXTXXX00NMG20S	<a href="#">XB72</a>
	Grasso speciale DT Swiss 20 g	HXT10032508S	<a href="#">XB97</a>
<b>Strumenti</b>	Cilindro di montaggio 15x26x40 mm	HWTXXX00N5290S	<a href="#">XB98</a>
	Strumento di montaggio/smontaggio per cricchetto filettato	HXTXXX00N9793S	<a href="#">XB99</a>
	Strumento di montaggio/smontaggio cuscinetto a sfera drive side (dx)	HWTXXX00N5290S	<a href="#">XC01</a>
	Strumento di montaggio guarnizione mozzo	HXTXXX00N9793S	<a href="#">XC02</a>

Cliccare sul codice ricambio per acquistare online. I ricambi per i mozzi sono disponibili esclusivamente per i rivenditori Orbea attraverso Kide (accesso B2B)

**MOZZI POSTERIORI DT SWISS****DT Swiss 350 J-bend 12x148 28/32H Centerlock/6 bulloni**

Consultare la tabella delle specifiche tecniche delle ruote OQUO per il modello di mozzo delle proprie ruote.

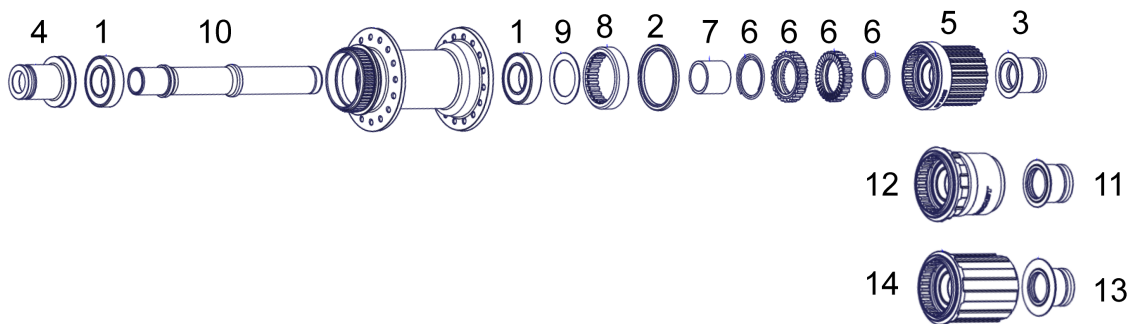

	DESCRIZIONE	NUMERO PER MOZZO	N. ARTICOLO DT SWISS	N. ARTICOLO ORBEA
1	CUSCINETTI 6902 ESB/ESNB L	2	HSBXXX00N2336S	<a href="#">XC06</a>
2	SEAL HUB/ROTOR (diam 30x36x2.5mm)	1	HSOXXX00N1031S	<a href="#">XB92</a>
3	ADATT. POST. WP XXX/12 R B MS	1	HWA00100S7912S	<a href="#">XC15</a>
4	ADATT. POST. WP XXX/12 L B	1	HWA00100S7841S	<a href="#">XC17</a>
5	FB W MTB SHI MS RAT AL LI SL B	1	HWRABL00S2148S	<a href="#">XC19</a>
6	KIT MANUTENZIONE RATCHET 36D SL	1	HWTXXX00NSK36S	<a href="#">XC20</a>
7	DISTANZIALE LEGA 15,4 mm BL	1	HCDXXX00S1077S	<a href="#">XC21</a>
8	DADO A GHIERA ACCIAIO M34X1 240	1	HXDXXX00N1131S	<a href="#">XC22</a>
9	ANELLO SPESSORE diam. 28/20X0,5 mm	1	HCDXXX00S1083S	<a href="#">XC23</a>
10	ASSE POSTERIORE AL 148 mm diam. 15/ 48,2 mm	1	HCCXXX00S6450S	<a href="#">XC24</a>
11	ADATT. POST. WP XXX/12 R B SRAM XD	1	HWA00100S7513S	<a href="#">XC25</a>
12	FB W MTB SRA XD RAT AL ST SL B	1	HWRAL00S3114S	<a href="#">XC26</a>
13	ADATT. POST. WP XXX/12 R B	1	HWA00100S7892S	<a href="#">XC27</a>
14	FB W MTB SHI RAT AL LI SL B	1	HWRABL00S1239S	<a href="#">XC28</a>

	DESCRIZIONE	N. ARTICOLO DT SWISS	N. ARTICOLO ORBEA
<b>Composto per il montaggio</b>	Grasso universale DT Swiss 20 g	HXTXXX00NMG20S	<a href="#">XB72</a>
	Grasso speciale DT Swiss 20 g	HXT10032508S	<a href="#">XB97</a>
<b>Strumenti</b>	Cilindro di montaggio 15x26x40 mm	HWTXXX00N5290S	<a href="#">XB98</a>
	Strumento di montaggio guarnizione mozzo	HXTXXX00N1000S	<a href="#">XC02</a>
	Utensile per ghiera	HXTXXX00N5027S	<a href="#">XC32</a>

Cliccare sul codice ricambio per acquistare online. I ricambi per i mozzi sono disponibili esclusivamente per i rivenditori Orbea attraverso Kide (accesso B2B)

**MOZZI POSTERIORI DT SWISS****DT Swiss 370 J-bend 12x148 28H 6 bulloni**

Consultare la tabella delle specifiche tecniche delle ruote OQUO per il modello di mozzo delle proprie ruote.

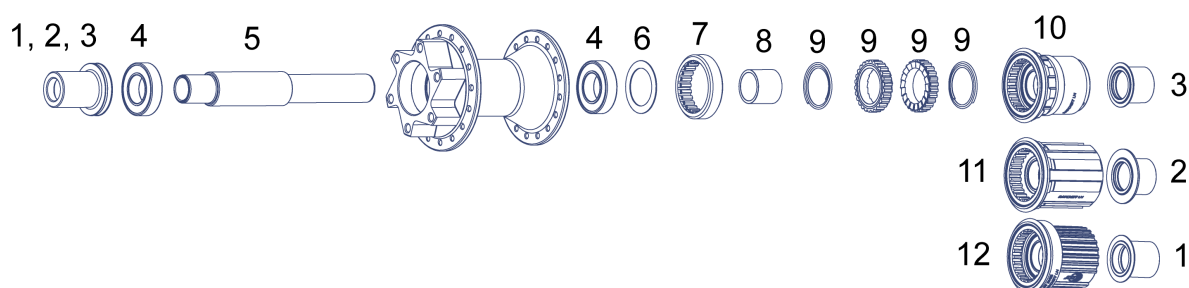

	DESCRIZIONE	NUMERO PER MOZZO	N. ARTICOLO DT SWISS	N. ARTICOLO ORBEA
1	KIT ADATT. RUOTA POST. XXX/12 B MS	1	HWGXXX00S5643S	X647
2	KIT CONVERSIONE X12 HG	2	HWGXXX0002193C	X648
3	KIT ADATT. RUOTA POST. 142/Ø12 240 SRAM XD	1	HWGXXX00S3188S	X649
4	CUSCINETTI 6902 ESB/ESNB M	1	HSBXXX00N3221S	XC06
5	ASSE POSTERIORE AL 148 mm diam. 15/48,2 mm	1	HCCXXX00S6450S	XC24
6	ANELLO SPESSORE diam. 28/20X0,5 mm	1	HCDXXX00S1083S	XC23
7	DADO A GHIERA ACCIAIO M34X1 240	2	HXDXXX00N1131S	XC22
8	RONDELLA LEGA 15,4 (ROTOR S)	2	HRDXXX00N4636S	XC35
9	KIT MANUTENZIONE H240/240S/FR/440	1	HWTXXX00NSK24S	X650
10	FB K MTB SRA XD LN 12/142/48 AL ST SM B	1	HWYABM00S3766S	X651
11	FB K MTB SHI LN 12/142/48 AF ST SM B	1	HWYABM00S3764S	X653
12	FB K MTB SHI MS LN 12/142/48 AL LI SM B	1	HWYABM00S3765S	X652

	DESCRIZIONE	N. ARTICOLO DT SWISS	N. ARTICOLO ORBEA
<b>Composto per il montaggio</b>	Grasso universale DT Swiss 20 g	HXTXXX00NMG20S	XB72
	Grasso speciale DT Swiss 20 g	HXT10032508S	XB97
<b>Strumenti</b>	Cilindro di montaggio 15x26x40 mm	HWTXXX00N5290S	XB98
	Strumento di montaggio guarnizione mozzo	HXTXXX00N1000S	XC02
	Utensile per ghiera	HXTXXX00N5027S	XC32

Cliccare sul codice ricambio per acquistare online. I ricambi per i mozzi sono disponibili esclusivamente per i rivenditori Orbea attraverso Kide (accesso B2B)

## MOZZI POSTERIORI DT SWISS

## DT Swiss 350 Hybrid J-bend 12x148 32H 6-bulloni (fino a MY2023)

Consultare la tabella delle specifiche tecniche delle ruote OQUO per il modello di mozzo delle proprie ruote.

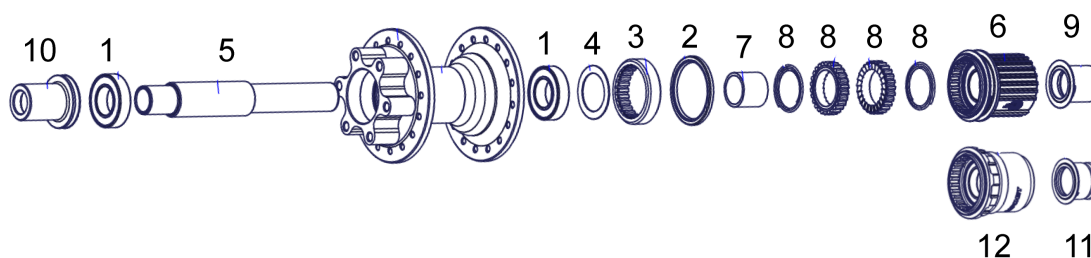

	DESCRIZIONE	NUMERO PER MOZZO	N. ARTICOLO DT SWISS	N. ARTICOLO ORBEA
1	CUSCINETTI 6902 ESB/ESNB L	2	HSBXXX00N2336S	XC06
2	GUARNIZIONE MOZZO/ROTORE (diam. 30x36x2,5 mm)	1	HSOXXX00N1031S	XB92
3	DADO A GHIERA ACCIAIO M34X1 240	1	HXDXXX00N1131S	XC22
4	ANELLO SPESSORE diam. 28/20X0,5 mm	1	HCDXXX00S1083S	XC23
5	ASSE POSTERIORE AL 148 mm diam 15/48,2 mm	1	HCCXXX00S6450S	XC24
6	FB W MHY SHI MS RAT ST ST SL B	1	HWRABL00S0758S	XC34
7	RONDELLA LEGA 15,4 (ROTOR S)	1	HRDXXX00N4636S	XC35
8	KIT MANUTENZIONE CRICCHETTO 24A	1	HWTXXX00NSKTFS	XC36
9	ADATT. POST. WP XXXR TA12 B MS	1	HWAXXX00S0491S	XC37
10	RW ADAPT WP 142L DBIS SA12 S	1	HWA00100S2193C	XC38
11	ADATT. POST. WP XXXR TA12 B SRAM XD	1	HWAXXX00S3188S	XC39
12	FB W MHY SRA XD RAT ST ST SL B	1	HWRAXL00S3224S	XC40

	DESCRIZIONE	N. ARTICOLO DT SWISS	N. ARTICOLO ORBEA
<b>Composto per il montaggio</b>	Grasso universale DT Swiss 20 g	HXTXXX00NMG20S	XB72
	Grasso speciale DT Swiss 20 g	HXT10032508S	XB97
<b>Strumenti</b>	Strumento di montaggio guarnizione mozzo	HXTXXX00N1000S	XC02
	Utensile per ghiera	HXTXXX00N5027S	XC32
	Diametro cil. installazione 15 / 28 x 35 mm	HXTXXX00N5024S	XC41

Cliccare sul codice ricambio per acquistare online. I ricambi per i mozzi sono disponibili esclusivamente per i rivenditori Orbea attraverso Kide (accesso B2B)

## MOZZI POSTERIORI DT SWISS

## DT Swiss 350 Hybrid J-bend 12x148 32H 6-bulloni (da MY2024)

Consultare la tabella delle specifiche tecniche delle ruote OQUO per il modello di mozzo delle proprie ruote.

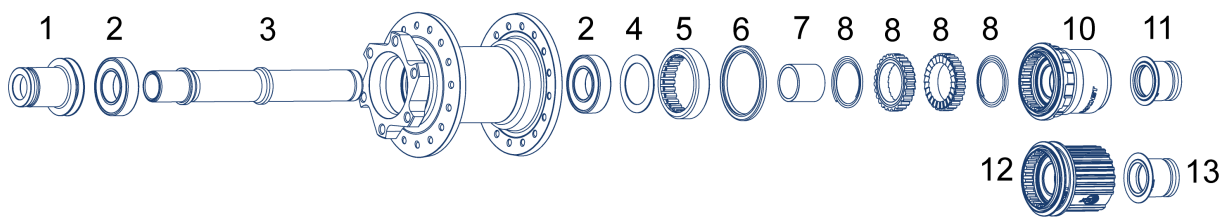

	DESCRIZIONE	NUMERO PER MOZZO	N. ARTICOLO DT SWISS	N. ARTICOLO ORBEA
1	ADATT. POST. WP XXX/12 L B	1	HWA00100S7841S	XC17
2	CUSCINETTI 6902 ESB/ESNB L	2	HSBXXX00N2336S	XC06
3	ASSE POSTERIORE AL 148MM Ø15/48,2 MM	1	HCCXXX00S6450S	XC24
4	ANELLO SPESSORE Ø28/20X0,5 MM	1	HCDXXX00S1083S	XC23
5	DADO A GHIERA ACCIAIO M34X1 240	1	HDXXXX00N1131S	XC22
6	GUARNIZIONE MOZZO/ROTORE (Ø30x36x2,5 mm)	1	HSOXXX00N1031S	XB92
7	DISTANZIALE LEGA 15,4 mm BL	1	HCDXXX00S1077S	XC21
8	KIT MANUTENZIONE CRICCHETTO 24A	1	HWTXXX00NSKTFS	XC36
10	FB W MHY SRA XD RAT ST ST SL B	1	HWRAXL00S3224S	XC40
11	ADATT. POST. WP XXX/12 R B SRAM XD	1	HWA00100S7513S	XC25
12	FB W MHY SHI MS RAT ST ST SL B	1	HWRABL00S3226S	XC34
13	ADATT. POST. WP XXX/12 R B MS	1	HWA00100S7912S	XC15

	DESCRIZIONE	N. ARTICOLO DT SWISS	N. ARTICOLO ORBEA
Composto per il montaggio	Grasso universale DT Swiss 20 g	HXTXXX00NMG20S	XB72
	Grasso speciale DT Swiss 20 g	HXT10032508S	XB97
Strumenti	Strumento di montaggio guarnizione mozzo	HXTXXX00N1000S	XC02
	Utensile per ghiera	HXTXXX00N5027S	XC32
	Diametro cil. installazione 15 / 28 x 35 mm	HXTXXX00N5024S	XC41

Cliccare sul codice ricambio per acquistare online. I ricambi per i mozzi sono disponibili esclusivamente per i rivenditori Orbea attraverso Kide (accesso B2B)

## RAGGI. KIT RAGGI RUOTA OQUO

## MOUNTAIN PERFORMANCE (MP)

MODELLO RUOTA	ANT. / POST.	MOZZO	DESCRIZIONE RICAMBIO	INCLUDE	QUANT.	COD. ART. ORBEA
MP30 LTD V1 fino a MY2024	ANTERIORE 29" 24H	DT SWISS 240 CLASSIC 24H	KIT RAGGI+NIPPLI MP30 LTD ANT. 24H V1	Sapim CX-Ray TCS Aero. 14G (2 mm). J-Bend. 293 mm. Nero	2	XB61
				Sapim CX-Ray TCS Aero. 14G (2 mm). J-Bend. 291 mm. Nero	2	
				Lega Sapim Double Square 2 x 18 mm. Nero	4	
	ANTERIORE 29" 28H	DT SWISS 240 CLASSIC 28H	KIT RAGGI+NIPPLI MP30LTD ANT. 28H V1	Sapim CX-Ray TCS Aero. 14G (2 mm). J-Bend. 299 mm. Nero	2	XB65
				Sapim CX-Ray TCS Aero. 14G (2 mm). J-Bend. 297 mm. Nero	2	
				Lega Sapim Double Square 2 x 18 mm. Nero	4	
	POSTERIORE 29" 28H	DT SWISS 240 CLASSIC 28H	KIT RAGGI+NIPPLI MP30LTD POST. 28H V1	Sapim CX-Ray TCS Aero. 14G (2 mm). J-Bend. 295 mm. Nero	2	XB86
				Sapim CX-Ray TCS Aero. 14G (2 mm). J-Bend. 296 mm. Nero	2	
				Lega Sapim Double Square 2 x 18 mm. Nero	4	
MP30 LTD V2 da MY2025	ANTERIORE 29" 24H	OQUO LTD SP DT SWISS INSIDE 240 24H	KIT RAGGI + NIPPLI MP30LTD ANT. 24H V2	DT aerolite T-shape Straightpull 2,0-(0,9x2,2)-2 mm. 301 mm. Nero	4	XH58
				DT Alloy Double Square 2x15 mm.	4	
	POSTERIORE 29" 28H	OQUO LTD SP DT SWISS INSIDE 240 28H	KIT RAGGI+NIPPLI MP30LTD POST. 28H V2	DT aerolite T-shape Straightpull 2,0-(0,9x2,2)-2 mm. 304 mm. Nero	4	XH59
				DT Alloy Double Square 2x15 mm.	4	
MP30 TEAM V1 fino a MY2024	ANTERIORE 29" 28H	DT SWISS 350 CLASSIC 28H	KIT RAGGI+NIPPLI MP30TEAM ANT. 28H V1	Sapim D-Sprint. Rinf. 14G (2 mm). J-Bend. 298 mm. Nero	2	XC03
				Sapim D-Sprint. Rinforzato. 14G (2 mm).J-Bend. 297m. Nero	2	
				Sapim Brass Polyax 2 x 14 mm. Nero	4	
	POSTERIORE 29" 28H	DT SWISS 350 CLASSIC 28H	KIT RAGGI+NIPPLI MP30TEAM POST. 28H V1	Sapim D-Sprint. Rinforzato. 14G (2 mm).J-Bend. 294m. Nero	2	XC12
				Sapim D-Sprint. Rinforzato. 14G (2 mm).J-Bend. 295m. Nero	2	
				Sapim Brass Polyax 2 x 14 mm. Nero	4	
MP30 TEAM V2 da MY2025	ANTERIORE 29" 28H	OQUO TEAM SP DT SWISS INSIDE 350 28H	KIT RAGGI+NIPPLI MP30 TEAM ANT. 28H V2	Sapim Sprint SP Rinf. 2,0/1,7/2,0 305 mm. Nero	4	XH61
				Lega Sapim Double Square 2 x 18 mm. Nero	4	
	POSTERIORE 29" 28H	OQUO TEAM SP DT SWISS INSIDE 350 28H	KIT RAGGI+NIPPLI MP30 TEAM POST. 28H V2	Sapim Sprint SP Rinf. 2,0/1,7/2,0 304 mm. Nero	4	XH62
				Lega Sapim Double Square 2 x 18 mm. Nero	4	
MP28 PRO fino a MY2023	ANTERIORE 29" 28H	DT SWISS 350 CLASSIC 28H	KIT RAGGI+NIPPLI MP28PRO ANT. 28H V1	Sapim Race. Rinf. 14G (2 mm).J-Bend. 298 mm. Nero	2	XC33
				Sapim Race. Rinforzato. 14G (2 mm). J-Bend. 297 mm. Nero	2	
				Sapim Brass Polyax 2 x 14 mm. Nero	4	
	POSTERIORE 29" 28H	DT SWISS 350 CLASSIC 28H	KIT RAGGI+NIPPLI MP28PRO POST. 28H V1	Sapim Race. Rinforzato. 14G (2 mm).J-Bend. 296m. Nero	2	XC14
				Sapim Race. Rinforzato. 14G (2 mm). J-Bend. 297 mm. Nero	2	
				Sapim Brass Polyax 2 x 14 mm. Nero	4	
MP28 PRO a partire da MY2024	ANTERIORE 29" 28H	DT SWISS 370 CLASSIC 28H	KIT RAGGI+NIPPLI MP28PRO ANT. 28H V2	Sapim Race. Rinforzato. 14G (2 mm). J-Bend. 297 mm. Nero	2	XD46
				Sapim Race. Rinforzato. 14G (2 mm). J-Bend. 296 mm. Nero	2	
				Sapim Brass Polyax 2 x 14 mm. Nero	4	
	POSTERIORE 29" 28H	DT SWISS 370 CLASSIC 28H	KIT RAGGI+NIPPLI MP28PRO POST. 28H V2	Sapim Race. Rinforzato. 14G (2 mm). J-Bend. 296 mm. Nero	2	XD47
				Sapim Race. Rinforzato. 14G (2 mm). J-Bend. 296 mm. Nero	2	
				Sapim Brass Polyax 2 x 14 mm. Nero	4	

Cliccare sul codice ricambio per acquistare online.

## RAGGI. KIT RAGGI RUOTA OQUO

## MOUNTAIN CONTROL (MC)

MODELLO RUOTA	ANT. / POST.	MOZZO	DESCRIZIONE RICAMBIO	INCLUDE	QUANT.	COD. ART. ORBEA
MC32 LTD V1 fino a MY2025	ANTERIORE 29" 28H	DT SWISS 350 CLASSIC 28H	KIT RAGGI+NIPPLI MC32LTD ANT. 28H V1	Sapim D-Sprint. Rinf. 14G (2 mm). J-Bend. 298 mm. Nero	2	XC29
				Sapim D-Sprint. Rinforzato. 14G (2 mm). J-Bend. 301 m. Nero	2	
				Sapim Brass Polyax 2 x 14 mm. Nero	4	
	POSTERIORE 29" 32H	DT SWISS 350 CLASSIC 32H	KIT RAGGI+NIPPLI MC32LTD POST. AR 32H V1	Sapim Race. Rinf. 14G (2 mm). J-Bend. 292 mm. Nero	4	XC30
			Sapim Brass Polyax 2 x 14 mm. Nero	4		
MC32 LTD V2 da MY2026	ANTERIORE 29" 28H	OQUO LTD JBEND 28H DT INSIDE 350	KIT RAGGI+NIPPLI MC32LTD ANT. 28H V2	Sapim Sprint. Rinforzato. 14G (2 mm).J-Bend. 299 mm. Nero	4	XJ99
				Sapim Brass Polyax 2 x 14 mm. Nero	4	
	POSTERIORE 29" 32H	OQUO LTD JBEND 32H DT INSIDE 350 DEG	KIT RAGGI+NIPPLI MC32LTD POST. 32H V2	Sapim Race. Rinforzato. 14G (2 mm).J-Bend. 291 mm. Nero	4	XK00
				Sapim Brass Polyax 2 x 14 mm. Nero	4	
MC32 TEAM V1 fino a MY2024	ANTERIORE 29" 28H	DT SWISS 350 CLASSIC 28H	KIT RAGGI+NIPPLI MC32TEAM TEAM ANT. 28H V1	Sapim D-Sprint. Rinforzato. 14G (2 mm).J-Bend. 299 mm. Nero	2	XC42
				Sapim D-Sprint. Rinforzato. 14G (2 mm). J-Bend. 297 mm. Nero	2	
				Sapim Brass Polyax 2 x 14 mm. Nero	4	
	POSTERIORE 29" 32H	DT SWISS 350 CLASSIC 32H	KIT RAGGI+NIPPLI MC32TEAM POST. 29 32H V1	Sapim Race. Rinforzato. 14G (2 mm).J-Bend. 291 mm. Nero	4	XC43
				Sapim Brass Polyax 2 x 14 mm. Nero	4	
	POSTERIORE 27,5" 32H	DT SWISS 350 CLASSIC 32H	KIT RAGGI+NIPPLI MC32TEAM POST. 27,5 32H V1	Sapim Race. Rinf. 14G (2 mm).J-Bend. 271 mm. Nero	4	XC44
Sapim Brass Polyax 2 x 14 mm. Nero				4		
MC32 TEAM V2 MY2025	ANTERIORE 29" 28H	DT SWISS 350 CLASSIC 28H	KIT RAGGI+NIPPLI MC32 TEAM ANT. 28H V2	Sapim D-Light Rinforzati. 14G (2 mm). J-Bend. 302 mm. Nero	2	XH63
				Sapim D-Light Rinforzati. 14G (2 mm). J-Bend. 300 mm. Nero	2	
				Lega Sapim Double Square 2 x 18 mm. Nero	4	
	POSTERIORE 29" 32H	DT SWISS 350 CLASSIC 32H	KIT RAGGI+NIPPLI MC32 TEAM POST. 29 32H V2	Sapim Sprint. Rinf. 14G (2 mm).J-Bend. 295 mm. Nero	4	XH64
				Lega Sapim Double Square 2 x 18 mm. Nero	4	
	POSTERIORE 27,5" 32H	DT SWISS 350 CLASSIC 32H	KIT RAGGI+NIPPLI MC32 TEAM POST. 27,5 32H V2	Sapim Sprint. Rinforzati. 14G (2 mm).J-Bend. 276 mm. Nero	4	XH65
Lega Sapim Double Square 2 x 18 mm. Nero				4		
MC32 TEAM V3 da MY2026	ANTERIORE 29" 28H	OQUO LTD JBEND 28H DT INSIDE 350	KIT RAGGI+NIPPLI MC32 TEAM ANT. 28H V3	Sapim D-Light. Rinf. 14G (2 mm).J-Bend. 298 mm. Nero	2	XK02
				Sapim D-Light. Rinf. 14G (2 mm).J-Bend. 297 mm. Nero	2	
				Lega Sapim Double Square 2 x 18 mm. Nero	4	
	POSTERIORE 29" 32H	OQUO LTD JBEND 32H DT INSIDE 350 DEG	KIT RAGGI+NIPPLI MC32 TEAM POST. 29 32H V3	Sapim Sprint. Rinforzato. 14G (2 mm). J-Bend. 291 mm. Nero	4	XK03
				Lega Sapim Double Square 2 x 18 mm. Nero	4	
	POSTERIORE 27,5" 32H	OQUO LTD JBEND 32H DT INSIDE 350 DEG	KIT RAGGI+NIPPLI MC32 TEAM POST. 27,5 32H V3	Sapim Sprint. Rinforzato. 14G (2 mm). J-Bend. 272 mm. Nero	4	XK04
Lega Sapim Double Square 2 x 18 mm. Nero				4		
MC32 TEAM RALLON DH (OEM) da MY2026	ANTERIORE 29" 28H	DT SWISS 350 CLASSIC 28H	KIT RAGGI+NIPPLI MC32 TEAM RALLON DH ANT. 28H (OEM) V1	Sapim Race. Rinforzato. 14G (2 mm).J-Bend. 296m. Nero	4	XK05
				Sapim Brass Polyax 2 x 14 mm. Nero	4	
	POSTERIORE 27,5" 32H	DT SWISS 350 CLASSIC 32H	KIT RAGGI+NIPPLI MC32 TEAM RALLON DH POST. 27,5 32H (OEM) V1	Sapim Race. Rinf. 14G (2 mm).J-Bend. 272 mm. Nero	4	XK06
				Sapim Brass Polyax 2 x 14 mm. Nero	4	

## RAGGI. KIT RAGGI RUOTA OQUO

## MOUNTAIN CONTROL (MC) POWER

MODELLO RUOTA	ANT. / POST.	MOZZO	DESCRIZIONE RICAMBIO	INCLUDE	QUANT.	COD. ART. ORBEA
MC32 LTD POWER fino a MY2023	POSTERIORE 29" 32H	DT SWISS 350 HYBRID CLASSIC 32H fino a MY2023	KIT RAGGI+NIPPLI MC32LTD POWER POST. 32H V1	Sapim E-Light. Rinf. 14G (2 mm). J-Bend. 292 mm. Nero	2	XC31
				Sapim E-Light. Rinforzato 14G (2 mm). J-Bend. 294 mm. Nero	2	
				Sapim Brass Polyax 2 x 14 mm. Nero	4	
MC32 LTD POWER a partire da MY2024	ANTERIORE 29" 28H	DT SWISS 350 HYBRID CLASSIC 28H a partire da MY2024	KIT RAGGI+NIPPLI MC32LTD POWER ANT. 28H V2	Sapim E-Light. Rinf. 14G (2 mm).J-Bend. 298 mm. Nero	2	XD49
				Sapim E-Light. Rinforzato 14G (2 mm). J-Bend. 299 mm. Nero	2	
				Sapim Brass Polyax 2 x 14 mm. Nero	4	
	POSTERIORE 29" 32H	DT SWISS 350 HYBRID CLASSIC 32H a partire da MY2024	KIT RAGGI+NIPPLI MC32LTD POWER POST. 32H V2	Sapim E-Light. Rinforzato. 14G (2 mm).J-Bend. 292 mm. Nero	2	XD50
				Sapim E-Light. Rinforzato 14G (2 mm). J-Bend. 291 mm. Nero	2	
				Sapim Brass Polyax 2 x 14 mm. Nero	4	
MC32 TEAM POWER V1 fino a MY2023	ANTERIORE 29" 32H	DT SWISS 350 HYBRID CLASSIC 32H fino a MY2023	KIT RAGGI+NIPPLI MC32TEAM POWER ANT. 32H V1	Sapim E-Light. Rinf. 14G (2 mm). J-Bend. 292 mm. Nero	2	XC45
				Sapim E-Light. Rinforzato. 14G (2 mm). J-Bend. 294 mm. Nero	2	
				Sapim Brass Polyax 2 x 14 mm. Nero	4	
	POSTERIORE 29" 32H	DT SWISS 350 HYBRID CLASSIC 32H fino a MY2023	KIT RAGGI+NIPPLI MC32TEAM POWER POST. 32H V1	Sapim E-Light. Rinf. 14G (2 mm).J-Bend. 291 mm. Nero	2	XC49
				Sapim E-Light. Rinforzato. 14G (2 mm). J-Bend. 293 mm. Nero	2	
				Sapim Brass Polyax 2 x 14 mm. Nero	4	
MC32 TEAM POWER V2 MY2024	ANTERIORE 29" 28H	DT SWISS 350 HYBRID CLASSIC 28H a partire da MY2024	KIT RAGGI+NIPPLI MC32TEAM POWER ANT. 28H V2	Sapim E-Light. Rinforzato. 14G (2 mm).J-Bend. 297m. Nero	2	XD51
				Sapim E-Light. Rinf. 14G (2 mm). J-Bend. 298 mm. Nero	2	
				Sapim Brass Polyax 2 x 14 mm. Nero	4	
	POSTERIORE 29" 32H	DT SWISS 350 HYBRID CLASSIC 32H a partire da MY2024	KIT RAGGI+NIPPLI MC32TEAM POWER POST. 29 32H V2	Sapim E-Light. Rinf. 14G (2 mm).J-Bend. 291 mm. Nero	2	XD52
				Sapim E-Light. Rinf. 14G (2 mm). J-Bend. 292 mm. Nero	2	
				Sapim Brass Polyax 2 x 14 mm. Nero	4	
	POSTERIORE 27,5" 32H	DT SWISS 350 HYBRID CLASSIC 32H a partire da MY2024	KIT RAGGI+NIPPLI MC32TEAM POWER POST. 27,5 32H V2	Sapim E-Light. Rinf. 14G (2 mm). J-Bend. 271 mm. Nero	4	XD54
				Sapim Brass Polyax 2 x 14 mm. Nero	4	
MC32 TEAM POWER V3 MY2025	ANTERIORE 29" 28H	DT SWISS 350 HYBRID CLASSIC 28H a partire da MY2024	KIT RAGGI+NIPPLI MC32 TEAM POWER ANT. 28H V3-V4	Sapim E-Light. Rinf. 14G (2 mm).J-Bend. 301 mm. Nero	2	XH71
				Sapim E-Light. Rinf. 14G (2 mm).J-Bend. 300 mm. Nero	2	
				Oquo nippli anodizzati 2 x 18 mm + rondelle	4	
	POSTERIORE 29" 32H	DT SWISS 350 HYBRID CLASSIC 32H a partire da MY2024	KIT RAGGI+NIPPLI MC32 TEAM POWER POST. 29 32H V3-V4	Sapim E-Light. Rinf. 14G (2 mm).J-Bend. 294 mm. Nero	2	XH72
				Sapim E-Light. Rinf. 14G (2mm).J-Bend. 295 mm. Nero	2	
				Oquo nippli anodizzati 2 x 18 mm + rondelle	4	
	POSTERIORE 27,5" 32H	DT SWISS 350 HYBRID CLASSIC 32H a partire da MY2024	KIT RAGGI+NIPPLI MC32 TEAM POWER POST. 27,5 32H V3-V4	Sapim E-Light. Rinforzati. 14G (2 mm).J-Bend. 276 mm. Nero	2	XH73
				Sapim E-Light. Rinf. 14G (2 mm). J-Bend. 275 mm. Nero	2	
				Oquo nippli anodizzati 2 x 18 mm + rondelle	4	

Cliccare sul codice ricambio per acquistare online.

**RAGGI. KIT RAGGI RUOTA OQUO****MOUNTAIN CONTROL (MC) POWER**

MODELLO RUOTA	ANT. / POST.	MOZZO	DESCRIZIONE RICAMBIO	INCLUDE	QUANT.	COD. ART. ORBEA
<b>MC32 TEAM POWER V4</b> da MY2026	ANTERIORE 29" 28H	DT SWISS 350 HYBRID CLASSIC 28H a partire da MY2024	KIT RAGGI+NIPPLI MC32 TEAM POWER ANT. 28H V3-V4	Sapim E-Light. Rinf. 14G (2 mm).J-Bend. 301 mm. Nero	2	XH71
				Sapim E-Light. Rinf. 14G (2 mm).J-Bend. 300 mm. Nero	2	
				Oquo nippli anodizzati 2 x 18 mm + rondelle	4	
	POSTERIORE 29" 32H	DT SWISS 350 HYBRID CLASSIC 32H a partire da MY2024	KIT RAGGI+NIPPLI MC32 TEAM POWER POST. 29 32H V3-V4	Sapim E-Light. Rinf. 14G (2 mm).J-Bend. 294 mm. Nero	2	XH72
				Sapim E-Light. Rinf. 14G (2mm).J-Bend. 295 mm. Nero	2	
				Oquo nippli anodizzati 2 x 18 mm + rondelle	4	
	POSTERIORE 27,5" 32H	DT SWISS 350 HYBRID CLASSIC 32H a partire da MY2024	KIT RAGGI+NIPPLI MC32 TEAM POWER POST. 27,5 32H V3-V4	Sapim E-Light. Rinforzati. 14G (2 mm).J-Bend. 276 mm. Nero	2	XH73
				Sapim E-Light. Rinf. 14G (2 mm). J-Bend. 275 mm. Nero	2	
				Oquo nippli anodizzati 2 x 18 mm + rondelle	4	

Cliccare sul codice ricambio per acquistare online.

## VALVOLE TUBELESS OQUO

### Installazione valvola tubeless su cerchi asimmetrici

Su alcuni cerchi OQUO con profilo asimmetrico occorre utilizzare l'adattatore asimmetrico tra il cerchio e il dado della valvola per far sì che la valvola si posizioni correttamente all'esterno del cerchio.

L'adattatore viene fornito con le ruote OQUO con profilo asimmetrico che lo richiedono.

Consultare la tabella nella sezione seguente per verificare quali modelli di ruota OQUO richiedono l'installazione dell'adattatore valvola asimmetrico.

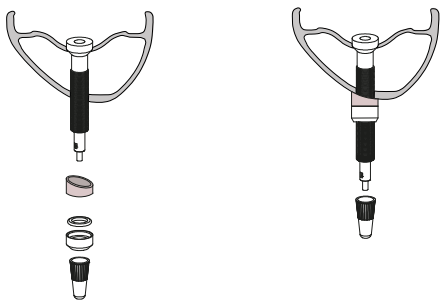

### Lunghezza valvola Tubeless

Consultare la tabella seguente per la lunghezza della valvola Tubeless usata per le tue ruote OQUO

FAMIGLIA	MODELLO RUOTA	LUNGHEZZA VALVOLE		ADATTATORE ASIMMETRICO
		Anteriore	Posteriore	
MOUNTAIN PERFORMANCE	MP30LTD	44 mm	44 mm	NO
	MP30TEAM	44 mm	44 mm	NO
	MP28PRO	40 mm	40 mm	Sì <b>XB66</b>
MOUNTAIN CONTROL	MC32LTD	44 mm	44 mm	NO
	MC32LTD POWER	44 mm	44 mm 57 mm sulla Wild con magnete nella valvola	NO
	MC32TEAM V1 (fino a MY2024)	44 mm	44 mm	Sì <b>XB66</b>
	MC32TEAM V2-V3 (da MY2025)	44 mm	44 mm	Sì <b>XH67</b>
	MC32 TEAM RALLON DH (da MY2026)	44 mm	44 mm	Sì <b>XH67</b>
	MC32 TEAM POWER V1 (fino a MY2023)	44 mm	44 mm 57 mm sulla Wild con magnete nella valvola	Sì <b>XB66</b>
	MC32 TEAM POWER V2-V4 (da MY2024)	44 mm	44 mm 57 mm sulla Wild con magnete nella valvola	Sì <b>XH67</b>

Cliccare sul codice ricambio per acquistare online.

### Strumento integrato nel tappo valvola OQUO

Le valvole OQUO Tubeless sono dotate di uno strumento per la rimozione del nucleo valvola Tubeless integrato nel tappo valvola.

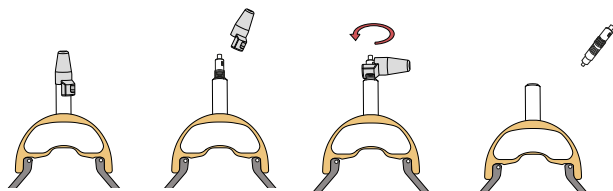

### Accessori OQUO

N. ARTICOLO	DESCRIZIONE	QUANT.	
X803	<b>KIT VALVOLA TUBELESS OQUO 44 mm</b> Con utensile per interno valvola	2	
X804	<b>KIT VALVOLA TUBELESS OQUO 44 mm + 57 mm</b> Con utensile per interno valvola Adattatore per cerchi asimmetrici non incluso		
XB67	<b>KIT VALVOLA TUBELESS OQUO</b> Interno valvola integrato	2	
XB66	<b>KIT ADATTATORE VALVOLA PER CERCHIO ASIMMETRICO V1</b> Consultare la tabella nella sezione precedente per verificare se le ruote Oquo della bici necessitano di un adattatore	2	
XH67	<b>KIT ADATTATORE VALVOLA PER CERCHIO ASIMMETRICO V2</b> Consultare la tabella nella sezione precedente per verificare se le ruote Oquo della bici necessitano di un adattatore	2	
XH28	<b>KIT CHIUSURA VALVOLA OQUO</b>	10	

Cliccare sul codice ricambio per acquistare online.

---

## ASSEMBLAGGIO RUOTE OQUO



Questa sezione contiene istruzioni generali per la raggiatura e la finitura per ruote OQUO, destinate ai rivenditori OQUO che debbano sostituire un cerchio dopo l'approvazione da parte di OQUO, e non è destinata all'uso come manuale per l'assemblaggio di ruote da bici.

L'assemblaggio corretto e sicuro delle ruote richiede conoscenze tecniche ed esperienza. Gli utenti o i tecnici che non hanno ricevuto una formazione adeguata o non hanno l'esperienza necessaria non possono assemblare ruote destinate all'utilizzo su una bici.



L'assemblaggio errato di una ruota può compromettere l'integrità strutturale e la durata della ruota stessa, e può essere causa di guasti dei componenti non coperti dalle condizioni di garanzia che possono a loro volta causare lesioni gravi o letali.

### STRUMENTI

Consultare la sezione Manutenzione delle ruote OQUO, nella quale si descrivono gli strumenti richiesti per la corretta manutenzione e l'assemblaggio delle ruote OQUO.

Per l'assemblaggio delle ruote, utilizzare sempre strumenti e prodotti adeguati. Strumenti non adatti o soggetti a scarsa manutenzione, oppure l'utilizzo di prodotti generici, possono causare danni ai componenti non coperti dalle condizioni di garanzia.

## CERCHI ASIMMETRICI

Se il cerchio ha un profilo asimmetrico (consultare la tabella delle specifiche nel presente manuale per verificare se un dato modello monta un cerchio asimmetrico), e orientare sempre il cerchio nel rispetto delle istruzioni seguenti.

- **Cerchi anteriori**

L'offset del cerchio deve essere orientato verso il lato drive side

- **Cerchi posteriori**

L'offset (disassamento) del cerchio va orientato verso il lato non-drive side.

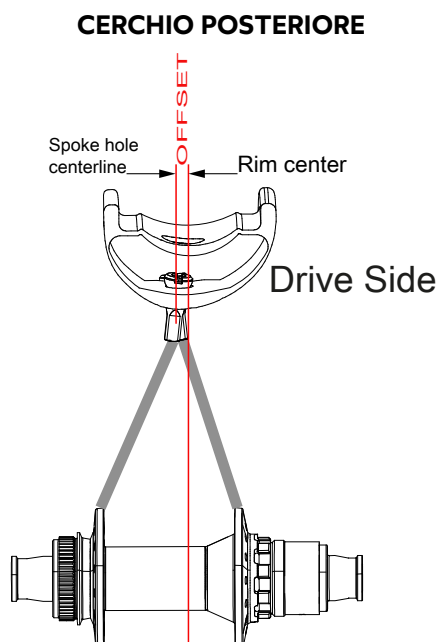
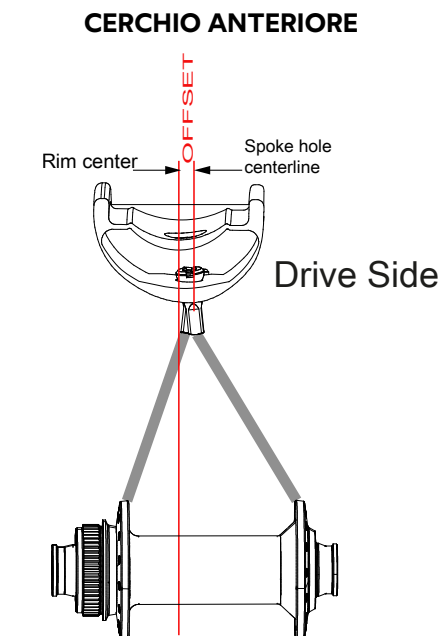

## CERCHI SIMMETRICI

In caso di cerchi simmetrici (non disassati), orientare il cerchio in modo tale che le decalcomanie e gli adesivi siano leggibili dallo stesso lato della bici dal quale erano leggibili sulla ruota originale.

## FORI DIREZIONALI PER I RAGGI

Se il cerchio è dotato di fori direzionali per i raggi, assemblare sempre la ruota in modo tale che l'orientamento dei fori nel cerchio corrisponda al relativo lato del mozzo.

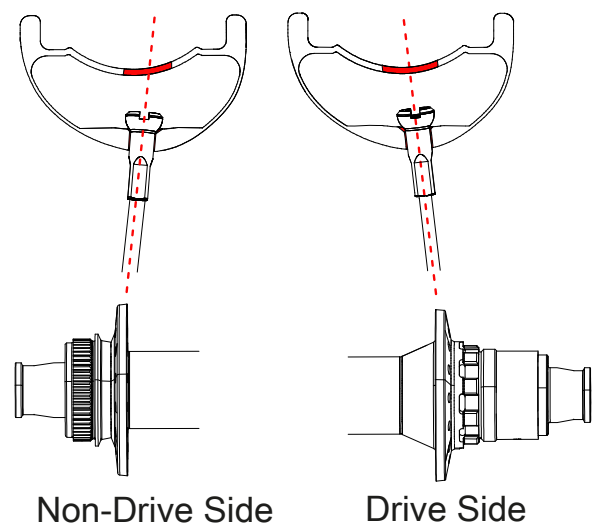

## CERCHI SPECIFICI PER RUOTA ANTERIORE E POSTERIORE

Sui modelli OQUO con cerchio specifico per ruota anteriore o posteriore, utilizzare sempre il cerchio progettato specificamente.

Nella tabella delle specifiche tecniche del presente manuale, è possibile verificare se il modello di bici monta cerchi specifici per la ruota anteriore o posteriore.

I cerchi specifici per ruote anteriori riportano la lettera F nel nome del modello.

I cerchi specifici per ruote posteriori riportano la lettera R nel nome del modello.

I cerchi che non sono specifici per ruote anteriori o posteriori riportano la lettera B nel nome del modello.

## RAGGI E NIPPLI

Utilizzare sempre i modelli di raggi e nippli specificati da OQUO per il modello di ruota.

I componenti di ciascun modello possono essere verificati nella tabella delle specifiche tecniche del presente manuale.

### RAGGI CLASSICI O STRAIGHTPULL CON TESTA A T

Su un mozzo straightpull si possono montare raggi classici o raggi straightpull con testa a T, a seconda della sede della testa del raggio.

Sui mozzi per raggi straightpull con testa a T, la sede della testa del raggio è rettangolare, per accogliere la testa del raggio e impedire che possa ruotare o allentarsi.

Sui mozzi classici straightpull la sede della testa del raggio è circolare, quindi i raggi dovranno avere la testa standard.

### RAGGI STRAIGHTPULL CON TESTA A T



### NIPPLI CON RONDELLE DI RINFORZO

Per alcuni nippli si utilizzano rondelle di rinforzo installate tra il nipplo e la spalla del cerchio.

Consultare la tabella delle specifiche per verificare l'eventuale necessità delle rondelle di rinforzo.

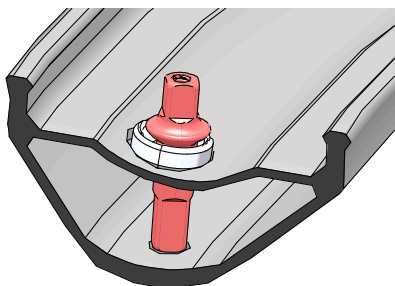

## RAGGIATURE J-BEND



A differenza delle configurazioni con raggi J-bend, nelle configurazioni con raggi straightpull la raggatura è predefinita dal mozzo e non può essere scelta al momento dell'assemblaggio della ruota.

Assemblare la ruota seguendo sempre la disposizione dei raggi originale, per ciascun lato della ruota stessa.

Verificare che i raggi si incrocino correttamente (sopra o sotto).

### 3 CROSS

Ciascun raggio incrocia altri tre raggi sullo stesso lato della ruota prima di essere fissato al cerchio.

In base al lato della flangia del mozzo da cui fuoriesce il raggio, vi sono due possibili posizioni del raggio rispetto agli altri tre raggi.

Se il raggio fuoriesce dal lato esterno della flangia del mozzo, la posizione rispetto ai raggi che attraversa dovrà essere:

- 01 Sopra
- 02 Sopra
- 03 Sotto

Se il raggio fuoriesce dal lato interno della flangia del mozzo, la posizione rispetto ai raggi che attraversa dovrà essere:

- 01 Sotto
- 02 Sotto
- 03 Sopra

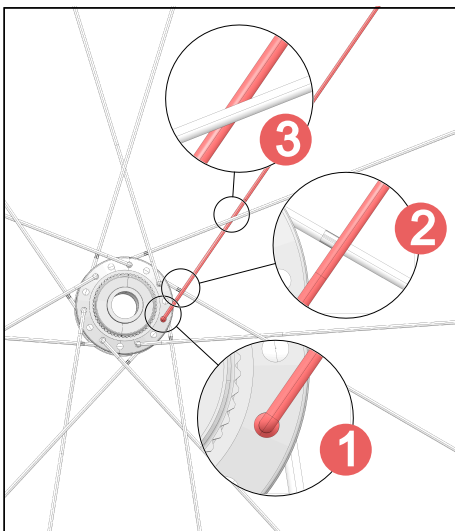

### 2 CROSS

Ciascun raggio incrocia altri due raggi sullo stesso lato della ruota prima di essere fissato al cerchio.

A seconda del lato della flangia del mozzo da cui fuoriesce il raggio, vi sono due possibili posizioni del raggio rispetto agli altri due raggi.

Se il raggio fuoriesce dal lato esterno della flangia del mozzo, la posizione rispetto ai raggi che attraversa dovrà essere:

- 01 Sopra
- 02 Sotto

Se il raggio fuoriesce dal lato interno della flangia del mozzo, la posizione rispetto ai raggi che attraversa dovrà essere:

- 01 Sotto
- 02 Sopra

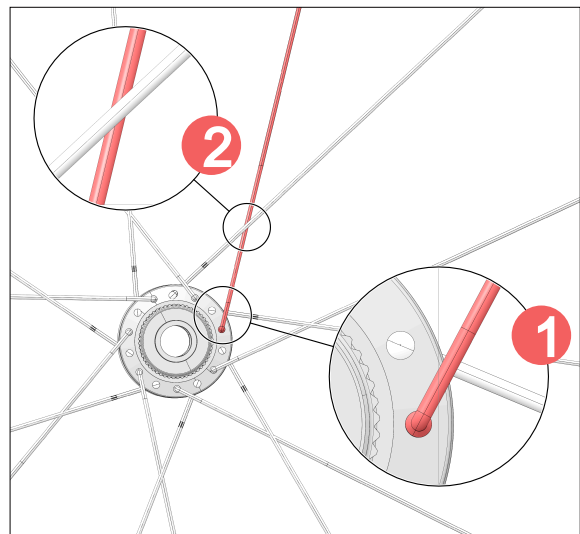

## POSIZIONE DEI RAGGI J-BEND "LEADING" E "TRAILING"



Nelle configurazioni con mozzo e raggi straightpull, la posizione dei raggi e del mozzo ha un solo verso e non può essere scelta al momento dell'assemblaggio della ruota.

Verificare la posizione dei raggi "leading" e "trailing" nella tabella delle specifiche presente in questo manuale, oppure sulla ruota originale, quindi raggiare la ruota nella stessa maniera, per ciascun lato della ruota.

### Raggio "trailing"

Raggio che fuoriesce dal mozzo in direzione opposta alla direzione di rotazione della ruota.

### Raggio "leading"

Raggio che fuoriesce dal mozzo nella stessa direzione di rotazione della ruota.

Le seguenti immagini sono esempi di disposizioni dei raggi. Verificare la disposizione dei raggi della ruota originale o la disposizione dei raggi nella tabella delle specifiche.



Direzione di rotazione della ruota

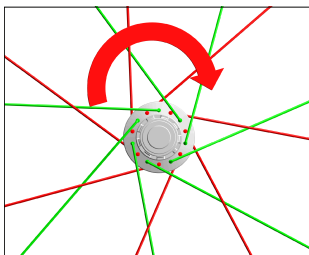

LATO DRIVE SIDE DELLA RUOTA POSTERIORE

**Trailing:** All'esterno della flangia del mozzo  
**Leading:** All'interno della flangia del mozzo

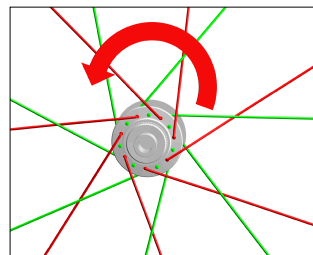

LATO NON-DRIVE SIDE DELLA RUOTA POSTERIORE

**Trailing:** All'interno della flangia del mozzo  
**Leading:** All'esterno della flangia del mozzo

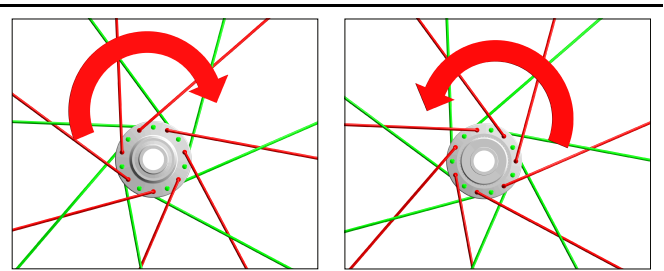

LATO DRIVE SIDE DELLA RUOTA ANTERIORE

**Trailing:** All'interno della flangia del mozzo  
**Leading:** All'esterno della flangia del mozzo

LATO NON-DRIVE SIDE DELLA RUOTA ANTERIORE

**Trailing:** All'interno della flangia del mozzo  
**Leading:** All'esterno della flangia del mozzo

## POSIZIONE DEL FORO VALVOLA

Per facilitare il gonfiaggio della ruota, il foro della valvola nel cerchio va posizionato tra due raggi paralleli.



### POSIZIONE DEL LOGO DEL MOZZO

Per motivi estetici, se sul corpo del mozzo è presente un logo, la posizione del mozzo in relazione al cerchio dovrà essere tale da consentire al logo di essere allineato con il foro valvola del cerchio.

Questo aspetto non ha effetti sul funzionamento della ruota, dunque gli assemblaggi che non soddisfano questa condizione sono considerati validi a tutti i fini, a condizione che tutti gli altri parametri di assemblaggio siano corretti.

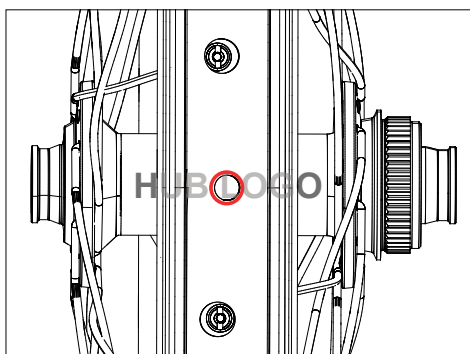

### PROCEDURA DI TENSIONAMENTO E CENTRATURA.

L'assemblaggio corretto e sicuro delle ruote richiede conoscenze tecniche ed esperienza. Gli utenti o i tecnici che non hanno ricevuto una formazione adeguata o non hanno l'esperienza necessaria non possono assemblare ruote destinate all'utilizzo su una bici.



Il presente manuale non include istruzioni complete sul processo completo di raggiatura e tensionamento delle ruote da bici, ma linee guida generali in merito a finitura e tolleranze delle ruote OQUO. Si tratta soltanto di una guida generale per il fissaggio e la finitura dei raggi per ruote OQUO, rivolta ai rivenditori OQUO che debbano sostituire un cerchio dopo l'approvazione da parte di OQUO, e non è prevista come manuale per l'assemblaggio di ruote da bici.



L'assemblaggio errato di una ruota può compromettere l'integrità strutturale e la durata della ruota stessa, e può essere causa di guasti dei componenti non coperti dalle condizioni di garanzia che potrebbero a loro volta causare lesioni gravi o letali.

Una volta che sono stati inseriti raggi e nippli della ruota senza aggiungere tensione, procedere con la centratura della ruota nel rispetto delle specifiche di tolleranza descritte nel presente manuale. Aumentare il tensionamento della ruota gradualmente e in modo uniforme. Eseguire le seguenti verifiche dopo aver regolato alcuni raggi.

OQUO consiglia il seguente processo di verifica dell'allineamento della ruota:

- 01** Verificare l'allineamento laterale
- 02** Verificare la centratura radiale
- 03** Verificare la centratura laterale sui due lati della ruota.

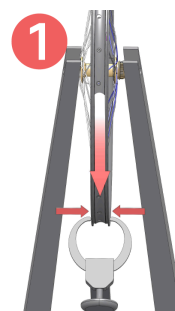

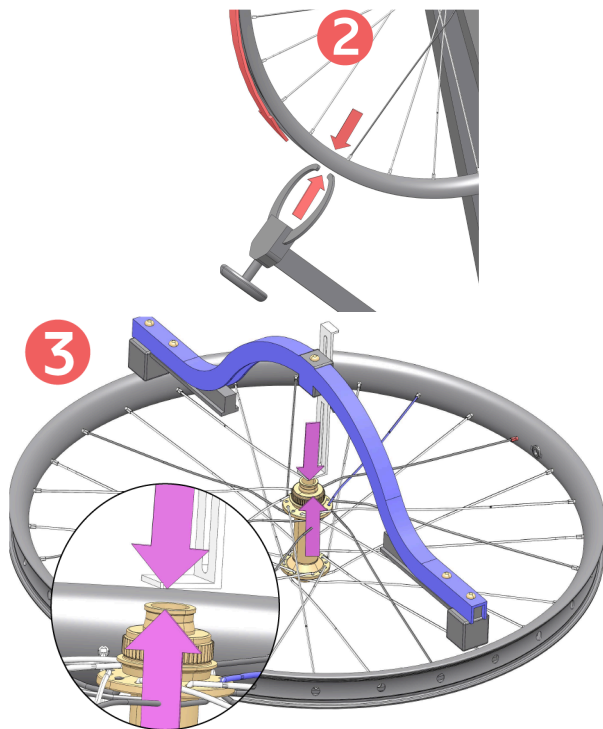

Ripetere queste verifiche secondo la necessità durante il processo di tensionamento dei raggi, ogni volta che si aumenta la tensione di più raggi, per evitare deviazioni eccessive che potrebbero danneggiare il cerchio.

#### AVVISO

Dopo ciascuna verifica di allineamento laterale, radiale e di campanatura, ridurre la tensione della ruota per consentire ai raggi di entrare in posizione e per ottenere verifiche veritiere.

Per rilasciare la tensione si può appoggiare la ruota su una faccia del mozzo su una superficie solida e spingere con le mani i lati opposti del cerchio in direzione della parte appoggiata del mozzo, con tutto il peso del corpo.

Effettuare questa verifica su entrambi i lati della ruota.

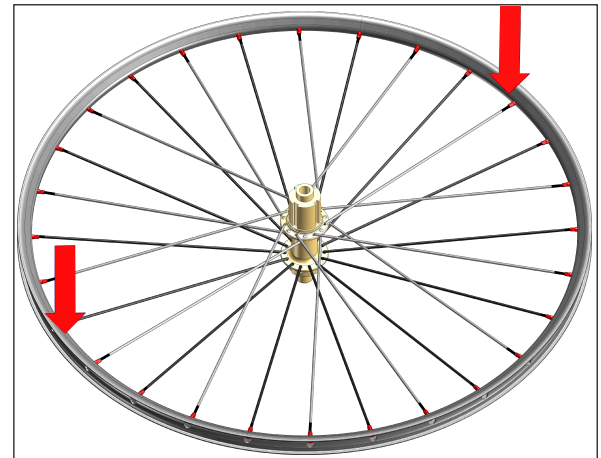

#### VERIFICA DELLA TENSIONE DEI RAGGI

Per il modello, in oggetto, verificare la tensione ottimale sul lato più in tensione di ciascuna ruota, nella Tabella delle specifiche tecniche del presente manuale (sezione Raggi). Una volta raggiunta la tensione prevista sul lato specificato della ruota, con i valori di deviazione laterale, radiale e di campanatura entro i limiti della tolleranza specificata, la tensione dei raggi sul lato meno in tensione dovrà risultare uniforme.

Utilizzare sempre un tensiometro di qualità e verificarne regolarmente la taratura in base alle istruzioni del produttore.

Attenersi alle istruzioni del produttore per un uso adeguato e per interpretare correttamente la lettura dei valori di tensione, in base alle specifiche del produttore.

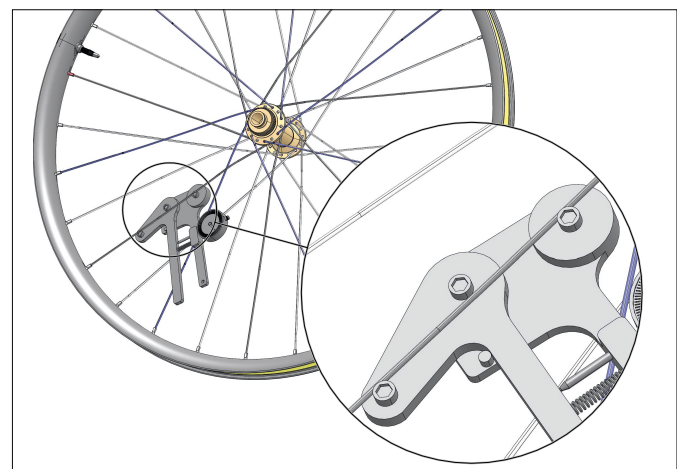

## COMPOSTO PER IL MONTAGGIO

Se si sta effettuando la manutenzione o la raggiatura di una delle nostre ruote, quando la ruota sarà stata correttamente centrata e tensionata, si consiglia l'applicazione sui filetti dei raggi di un composto frenafilletti di media resistenza che sia il più fluido possibile.

## ISTRUZIONI DI ASSEMBLAGGIO RUOTE OQUO E TOLLERANZE

TENSIONE DI ASSEMBLAGGIO DELLA RUOTA OQUO	
TENSIONE	<p><b>Controllare la tensione prevista per il lato più serrato di ciascuna ruota per il proprio modello nella tabella delle Specifiche Tecniche del presente manuale (sezione Raggi).</b></p> <p>Una volta raggiunta la tensione prevista sul lato specificato della ruota, con i valori di deviazione laterale, radiale e di campanatura entro i limiti della tolleranza specificata, la tensione dei raggi sul lato meno in tensione dovrà essere uniforme.</p>
	<p><b>TOLLERANZA DI TENSIONE MEDIA DEI RAGGI, SUL LATO PIÙ SERRATO DELLA RUOTA</b></p>
	<p>+/- 5%</p>

Utilizzare sempre un tensiometro di qualità e verificarne regolarmente la taratura in base alle istruzioni del produttore. Attenersi alle istruzioni del produttore per un uso adeguato e per interpretare correttamente la lettura dei valori di tensione, in base alle specifiche del produttore.

DEVIAZIONE		LATERALE	RADIALE	INCURVAMENTO
	Alluminio	0,4 mm	0,6 mm	0,6 mm
Carbonio	0,3 mm	0,6 mm	0,3 mm	

---

## INFORMAZIONI AGGIUNTIVE

Trova maggiori informazioni su OQUO nei social media

### FACEBOOK

[www.facebook.com/oquo.wheels](http://www.facebook.com/oquo.wheels)

### INSTAGRAM

[www.instagram.com/oquo.wheels/](http://www.instagram.com/oquo.wheels/)

### LINKEDIN

[www.linkedin.com/company/oquowheels/](http://www.linkedin.com/company/oquowheels/)

### YOUTUBE

[www.youtube.com/channel/UCpXzSOB\\_9oLzLzAnnwuaGCg](http://www.youtube.com/channel/UCpXzSOB_9oLzLzAnnwuaGCg)

### MANUALI

Scarica l'ultima versione di questo manuale e di tutti gli altri prodotti OQUO sul sito:

[www.oquowheels.com/en-int/support/manuals](http://www.oquowheels.com/en-int/support/manuals)

### CONTATTI

Per porre domande sui nostri prodotti, visita il sito:

[www.oquowheels.com/en-int/support/contact](http://www.oquowheels.com/en-int/support/contact)

---

**Orbea OQUO SL 2025**  
**Polígono Industrial Kareaga, 2. NAV 49,**  
**Markina-Xemein. 48270. Bizkaia**  
**T. 0034 943 171 950**

Tutti i diritti riservati. La modifica del presente documento è vietata.

Il presente manuale tecnico per il prodotto ha uno scopo puramente informativo in relazione all'assemblaggio, l'installazione e la manutenzione del prodotto e, pertanto, sarà soggetto a modifiche delle specifiche e/o a futuri aggiornamenti dei contenuti da parte del produttore. I contenuti del manuale non hanno alcun valore promozionale o contrattuale in relazione al prodotto descritto e non dovranno essere considerati dall'utente come suggerimenti riguardo alla decisione di acquistare il prodotto. Pertanto, non assumiamo alcuna responsabilità nei confronti dell'utente o di terze parti nel caso in cui questo manuale dovesse essere utilizzato per finalità diverse da quelle previste e specificate in esso.

Tutti i diritti riservati. La modifica del presente documento è vietata. I contenuti del presente manuale sono soggetti a variazioni delle specifiche senza preavviso.

Per la versione più aggiornata, visita: [www.oquowheels.com](http://www.oquowheels.com)

## INDICE

<b>Introduction</b>	<b>264</b>
<b>Types de manuel</b>	<b>265</b>
<b>Légende des symboles</b>	<b>266</b>
<b>Avertissements généraux concernant ce manuel technique</b>	<b>267</b>
<b>Spécifications techniques et de montage des roues Oquo</b>	<b>268</b>
Tableau de la gamme de roue OQUO VTT	268
Mountain Performance (MP)	269
MP30 LTD (jusqu'à l'année-modèle 2024)	269
MP30 LTD (à partir de l'année-modèle 2025)	270
MP30 TEAM (jusqu'à l'année-modèle 2024)	271
MP30 TEAM (à partir de l'année-modèle 2025)	272
MP28 PRO (jusqu'à l'année-modèle 2023)	273
MP28 PRO (à partir de l'année-modèle 2024)	274
Mountain Control (MC)	275
MC32 LTD (jusqu'à l'année-modèle 2025)	275
MC32 LTD (à partir de l'année-modèle 2026)	276
MC32 LTD POWER (jusqu'à l'année-modèle 2023)	277
MC32 LTD POWER (à partir de l'année-modèle 2024)	278
MC32 TEAM (jusqu'à l'année-modèle 2024)	279
MC32 TEAM (Année-modèle 2025)	280
MC32 TEAM (à partir de l'année-modèle 2026)	281
MC32 TEAM RALLON DH Année-modèle 2026 (OEM)	282
MC32 TEAM POWER (jusqu'à l'année-modèle 2023)	283
MC32 TEAM POWER (Année-modèle 2024)	284
MC32 TEAM POWER (Année-modèle 2025)	285
MC32 TEAM POWER (à partir de l'année-modèle 2026)	286
<b>Entretien des roues Oquo</b>	<b>287</b>
Tableau du calendrier d'entretien	287
Outillage	287
<b>Entretien du moyeu</b>	<b>293</b>
<b>Pièces de rechange</b>	<b>295</b>
Pièces de rechange pour moyeux DT Swiss Inside OQUO	295
Moyeux avant DT Swiss Inside Oquo	295
Oquo LTD DT Swiss 240 Inside Straight Pull 15x110 24 trous Centerlock	295

Oquo TEAM DT Swiss 350 Inside Straight Pull 15x110 28 trous Centerlock/6 vis	296
Oquo LTD DT Swiss 350 Inside coudé 15x110 28 trous 6 vis	297
Moyeux arrière DT Swiss Inside Oquo	298
Oquo LTD DT Swiss 240 Inside Straight Pull 12x148 28 trous Centerlock	298
Oquo LTD DT Swiss 350 Inside Straight Pull 12x148 28/32 trous Centerlock/6 vis	299
Oquo LTD DT Swiss Inside 350 DEG coudé 12x148 32 trous 6 vis	300
Pièces de rechange pour les moyeux DT Swiss	301
Moyeux avant DT Swiss	301
DT Swiss 240 coudé 15x110 24/28 trous Centerlock/6 vis	301
DT Swiss 350 coudé 15x110 28 trous Centerlock/6 vis	302
DT Swiss 350 coudé 20x110 28 trous 6 vis	303
DT Swiss 370 coudé 15x110 28 trous 6 vis	304
DT Swiss 350 Hybrid coudé 15x110 32 trous (jusqu'à l'année-modèle 2023) 6 vis	305
DT Swiss 350 Hybrid coudé 15x110 28 trous (à partir de l'année-modèle 2024) 6 vis	306
Moyeux arrière DT Swiss	307
DT Swiss 240 coudé 12x148 28 trous Centerlock	307
DT Swiss 350 coudé 12x148 28/32 trous Centerlock/6 vis	308
DT Swiss 370 coudé 12x148 28 trous 6 vis	309
DT Swiss 350 Hybrid coudé 12x148 32 trous (jusqu'à l'année-modèle 2023) 6 vis	310
DT Swiss 350 Hybrid coudé 12x148 32 trous (à partir de l'année-modèle 2024) 6 vis	311
Rayons. Jeux de rayons pour roue Oquo	312
Valves Tubeless Oquo	316
<b>Montage de roue Oquo</b>	<b>318</b>
<b>Informations supplémentaires</b>	<b>326</b>

---

## INTRODUCTION

Les informations reprises dans ce manuel sont destinées avant tout aux revendeurs OQUO et aux utilisateurs qui possèdent un peu d'expérience en entretien de roues.

Si vous êtes un utilisateur qui ne dispose pas des connaissances requises pour exécuter les interventions d'entretien décrites dans ce manuel technique ou pour installer les pièces de rechange mentionnées, rendez-vous chez un revendeur OQUO qui se chargera de la réparation ou de l'entretien.

Vous trouverez les coordonnées du revendeur le plus proche sur notre site Internet :

[www.oquowheels.com](http://www.oquowheels.com)

### ATTENTION

---

Tout dégât provoqué par une réparation ou un entretien mal exécuté est exclu de la garantie.



Une réparation, un entretien ou une installation de composants incorrects peut avoir un impact sur l'intégrité et le fonctionnement des roues et provoquer un accident entraînant des blessures graves ou mortelles.

---

## TYPES DE MANUEL

### MANUEL TECHNIQUE

Ce manuel présente les caractéristiques techniques, décrits les procédures d'entretien et fournit une liste de pièces de rechange d'origine pour les produits OQUO. Il est destiné aux revendeurs spécialisés et aux utilisateurs dotés des compétences nécessaires.

S'agissant des procédures d'entretien de composants tiers utilisés sur nos roues, nous fournissons les liens vers la documentation pertinente du fabricant.

Les procédures, les caractéristiques techniques et les pièces de rechange décrites dans ce manuel peuvent changer dans les caractéristiques techniques des produits.

La version la plus récente de ce manuel technique est disponible sur le site Internet d'OQUO.

### MANUEL DE L'UTILISATEUR

Si vous souhaitez consulter le manuel d'utilisation de nos roues, qui explique en détails l'utilisation adéquate des roues, présente les mises en garde d'utilisation, de transport et de rangement, explique l'installation, etc., lisez le manuel publié sur notre site Internet.

Toute la documentation relative aux produits ainsi que les informations pertinentes liées à la garantie et aux programmes d'entretien sont disponibles sur notre site Internet :

[www.oquowheels.com/es-es/soporte/manuales](http://www.oquowheels.com/es-es/soporte/manuales)

---

## LÉGENDE DES SYMBOLES

Vous retrouverez tout au long de ce manuel différents symboles qui signalent des instructions ou des avertissements sur l'utilisation, l'entretien et l'assemblage. Il convient de prêter attention à ces symboles afin d'éviter des situations dangereuses et de garantir l'assemblage et l'utilisation corrects de l'ensemble des composants.

Vous trouverez ci-dessous la signification de ces symboles. Dans ce manuel, un symbole peut être accompagné uniquement des instructions pertinentes pour le composant qu'il décrit. Lisez attentivement les informations suivantes pour en comprendre la signification.

### CONSIGNES DE SÉCURITÉ



---

**DANGER** : une situation dangereuse qui, si elle n'est pas évitée, entraînera des blessures graves, voire mortelles.



---

**AVERTISSEMENT** : une situation dangereuse qui, si elle n'est pas évitée, pourrait entraîner des blessures graves, voire la mort.



---

**MISE EN GARDE** : une situation dangereuse qui, si elle n'est pas évitée, peut entraîner des blessures mineures ou modérées.

#### ATTENTION

---

Situation non liée à une blessure physique. Informations pertinentes.

Les symboles DANGER et AVERTISSEMENT impliquent toujours un risque d'accident si des mesures ne sont pas prises afin d'éviter la situation qu'ils décrivent. Un accident à vélo peut toujours entraîner un risque de blessure grave, voire mortelle. Le risque de décès ne sera pas toujours répété dans ce manuel lorsque ces symboles apparaissent, car le risque est détaillé ici.

### OUTILLAGE

Utilisez toujours les outils et les produits adéquats pour une intervention d'entretien ou une réparation particulière. L'utilisation d'outils mal adaptés ou en mauvais état ou de produits génériques peut endommager les composants et ces dégâts ne sont pas couverts par la garantie.

Les outils à utiliser sont spécifiés dans ce manuel. S'agissant des outils à utiliser pour l'entretien des composants d'autres fabricants utilisés sur nos roues, vous trouverez des références vers les manuels d'entretien et les listes respectives d'outils requis.

---

## AVERTISSEMENTS GÉNÉRAUX CONCERNANT CE MANUEL TECHNIQUE

- Pour lire les instructions d'installation, la procédure d'entretien et les avertissements concernant l'utilisation des composants de fabricants tiers utilisés sur nos roues, comme les disques de frein, les cassettes, les pneus, etc., consultez la documentation du fabricant de ce composant.
- Tenez éloigné tout membre de votre corps et/ou vêtement des disques de frein et des rayons pendant l'utilisation ou le réglage afin d'éviter de vous couper ou de vous blesser grièvement.
- En règle générale, lavez tous les composants après l'entretien avant de les reposer.
- Veillez à ce que les roues et de leurs composants restent propres et évitez l'accumulation de corps étrangers. Ainsi, vous garantirez leur bon fonctionnement et l'évaluation de leur état sera simplifiée.
- Nettoyez toujours vos roues et leurs composants à l'aide d'un chiffon doux et de produits de nettoyage spécifiques.
- Évitez de nettoyer les roues et leurs composants avec un nettoyeur haute pression ou avec des produits chimiques agressifs. L'eau sous haute pression peut diluer le lubrifiant, réduire sa durée de vie et/ou provoquer des dégâts qui ne sont pas couverts par la garantie.

### PIÈCES DE RECHANGE

Utilisez uniquement les pièces de rechange OQUO d'origine ou celles citées dans ce manuel ou dans la documentation fournie par le fabricant du composant.

#### ATTENTION

---

L'utilisation de pièce de rechange qui ne sont pas d'origine peut endommager les composants. Ce genre de dégât n'est pas couvert par la garantie.



---

Le recours à des pièces de rechange qui ne sont pas d'origine peut également provoquer un dysfonctionnement des composants et entraîner des accidents et des blessures graves.

## SPÉCIFICATIONS TECHNIQUES ET DE MONTAGE DES ROUES OQUO

Les tableaux suivants reprennent les détails relatifs aux composants et à l'assemblage de tous les modèles OQUO VTT.

Les données de ces tableaux sont référencées tout au long de ce manuel, lorsqu'elles se rapportent à des sections spécifiques. Consultez ces tableaux pour trouver les données que vous cherchez.

**TABLEAU DE LA GAMME DE ROUE OQUO VTT**

	<b>GAMME</b>	<b>MODÈLE</b>	<b>CATÉGORIE</b>
VTT	<b>MOUNTAIN PERFORMANCE (MP)</b>	<b>MP30LTD</b>	XC, MARATHON, TRAIL
		<b>MP30TEAM</b>	
		<b>MP28PRO</b>	
	<b>MOUNTAIN CONTROL (MC)</b>	<b>MC32LTD</b>	TRAIL, ENDURO, GRAVITY
		<b>MC32LTD POWER</b>	E-ENDURO, GRAVITY
		<b>MC32TEAM</b>	TRAIL, ENDURO, GRAVITY
		<b>MC32TEAM POWER</b>	E-ENDURO, GRAVITY

## MOUNTAIN PERFORMANCE (MP)

## MP30 LTD (jusqu'à l'année-modèle 2024)

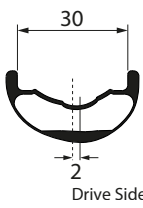
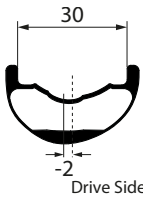
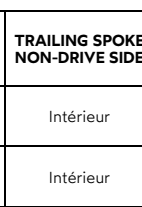
	MODÈLE	MATÉRIAU	TAILLE	TYPE DE JANTE	TYPE DE FREIN	TUBELESS	LARGEUR INTERNE	DÉPORT	TROUS DE RAYON DIRECTIONNELS	TROUS DE RAYON	ERD	ETRTO	RAC-CORD	LARGEUR DE FOND TUBELESS	VAVLE	PNEUS COMPATIBLES	PRESSION MAXIMALE	PROFIL	
JANTES	JANTE AVANT (28H)	MP10-F-29-28H	Carbone	29"	Chambre à air sans crochet	Disque	OUI	30 mm	2 mm	OUI	28	611 mm	622 x 30TSS	—	30 mm	44 mm	2,05"-2,8"	**	
	JANTE AVANT (24H)	MP11-F-29-24H	Carbone	29"	Chambre à air sans crochet	Disque	OUI	30 mm	2 mm	OUI	24	611 mm	622 x 30TSS	—	30 mm	44 mm	2,05"-2,8"	**	
	JANTE ARRIÈRE	MP10-R-29-28H	Carbone	29"	Chambre à air sans crochet	Disque	OUI	30 mm	-2 mm	OUI	28	607,6 mm	622 x 30TSS	—	30 mm	44 mm	2,05"-2,8"	**	

	No. SPOKES	MODEL	DRIVE SIDE SPOKE PATTERN	NON-DRIVE SIDE SPOKE PATTERN	DRIVE SIDE SPOKE LENGTH	NON-DRIVE SIDE SPOKE LENGTH	DRIVE SIDE ASSEMBLY TENSION	DISC SIDE ASSEMBLY TENSION	LEADING SPOKE DRIVE SIDE	TRAILING SPOKE DRIVE SIDE	LEADING SPOKE NON-DRIVE SIDE	TRAILING SPOKE NON-DRIVE SIDE
RAYONS	AVANT (28H)	Sapim CX-Ray TCS Aero 14G (2 mm) coudé	3 rayons croisés	3 rayons croisés	299 mm	297 mm	—	1 200 N	Extérieur	Intérieur	Extérieur	Intérieur
	AVANT (24 TROUS)	Sapim CX-Ray TCS Aero 14G (2 mm) coudé	3 rayons croisés	3 rayons croisés	293 mm	291 mm	—	1 200 N	Extérieur	Intérieur	Extérieur	Intérieur
	ARRIÈRE	Sapim CX-Ray TCS Aero 14G (2 mm) coudé	3 rayons croisés	3 rayons croisés	295 mm	296 mm	1300 N	—	Intérieur	Extérieur	Extérieur	Intérieur

	MODEL	SPACING (OLD)	AXLE	DISC TYPE	SPOKES	FREEHUB BODY	FREEHUB MECHANISM		MODEL	MEASUREMENTS	SPOKE NIPPLE WASHERS	ROUE	POIDS	USE  <b>ASTM Condition 3</b> (cf. manuel d'utilisateur)  Poids maximal du système (vélo + cycliste + équipement) = <b>110 kg.</b>	
MOYEU	MOYEU AVANT (28 TROUS)	DT SWISS 240 Classic CL	Boost 110 mm	Thru axle 15mm	Verrouillage central	28 coudé	—	—	AVANT (28H)	Sapim Alloy Double Square	2 x 18 mm (14G)	Non	AVANT (28H)		625 gr +/- 5 %
	MOYEU AVANT (24 TROUS)	DT SWISS 240 Classic CL	Boost 110 mm	Thru axle 15mm	Verrouillage central	24 coudé	—	—	AVANT (24 TROUS)	Sapim Alloy Double Square	2 x 18 mm (14G)	Non	AVANT (24 TROUS)		591gr +/- 5 %
	MOYEU ARRIÈRE	DT SWISS 240 Classic CL	Boost 148 mm	Thru axle 12 mm	Verrouillage central	28 coudé	Sram XD ou Shimano Microspline	Ratchet EXP 36	ARRIÈRE	Sapim Alloy Double Square	2 x 18 mm (14G)	Non	ARRIÈRE		730 gr +/- 5 %
EMBOUTS															

\*\* Pour connaître la pression des pneus maximale, reportez-vous au manuel du propriétaire ou à l'autocollant qui se trouve sur la roue.

[Cliquez sur le modèle de moyeu ou de rayon pour accéder aux informations sur les pièces détachées](#)

## MOUNTAIN PERFORMANCE (MP)

## MP30 LTD (à partir de l'année-modèle 2025)

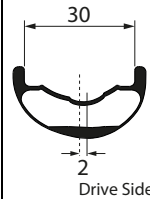
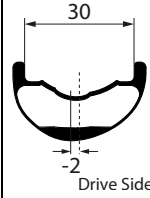
	MODÈLE	MATÉRIAU	TAILLE	TYPE DE JANTE	TYPE DE FREIN	TUBELESS	LARGEUR INTERNE	DÉPORT	TROUS DE RAYON DIRECTIONNELS	TROUS DE RAYON	ERD	ETRTO	RACCORD	LARGEUR DE FOND TUBELESS	VAVLE	PNEUS COMPATIBLES	PRESSION MAXIMALE	PROFIL	
JANTES	JANTE AVANT	MP11-F-29-24H	Carbone	29"	Chambre à air sans crochet	Disque	OUI	30 mm	2 mm	OUI	24	601 mm	622 x 30TSS	—	30 mm	44 mm	2,05"-2,8"	**	
	JANTE ARRIÈRE	MP10-R-29-28H	Carbone	29"	Chambre à air sans crochet	Disque	OUI	30 mm	-2 mm	OUI	28	599 mm	622 x 30TSS	—	30 mm	44 mm	2,05"-2,8"	**	

	No. SPOKES	MODEL	DRIVE SIDE SPOKE PATTERN	NON-DRIVE SIDE SPOKE PATTERN	DRIVE SIDE SPOKE LENGTH	NON-DRIVE SIDE SPOKE LENGTH	DRIVE SIDE ASSEMBLY TENSION	DISC SIDE ASSEMBLY TENSION	
RAYONS	AVANT (24 TROUS)	24	En T DT aerolite SP* 2,0-(0,9x2,2)-2 mm	2 rayons croisés	2 rayons croisés	301 mm	301 mm	—	1200 N
	ARRIÈRE	28	En T DT aerolite SP* 2,0-(0,9x2,2)-2 mm	3 rayons croisés	3 rayons croisés	304 mm	304 mm	1300 N	—

MOYEURS	MODEL	SPACING (OLD)	AXLE	DISC TYPE	SPOKES	FREEHUB BODY	FREEHUB MECHANISM	EMBOUTS	MODEL	MEASUREMENTS	SPOKE NIPPLE WASHERS	POIDS	ROUE	POIDS	USE:
	MOYEU AVANT	OQUO LTD DT 240 INSIDE	Boost 110 mm	Thru axle 15mm	Verrouillage central	24 SP*	—		—	AVANT	DT carré double alliage		2x15 mm (FG 2,3)		
MOYEU ARRIÈRE	OQUO LTD DT 240 INSIDE	Boost 148 mm	Thru axle 12 mm	Verrouillage central	28 SP*	Sram XD ou SP Shimano Microspline	DT Swiss Ratchet EXP 10° / 36	ARRIÈRE	DT carré double alliage	2x15 mm (FG 2,3)	Non	ARRIÈRE	740 g +/-5 %		

\*SP : Straightpull

\*\* Pour connaître la pression des pneus maximale, reportez-vous au manuel du propriétaire ou à l'autocollant qui se trouve sur la roue.

Cliquez sur le modèle de moyeu ou de rayon pour accéder aux informations sur les pièces détachées

## MOUNTAIN PERFORMANCE (MP)

## MP30 TEAM (jusqu'à l'année-modèle 2024)

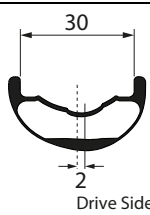
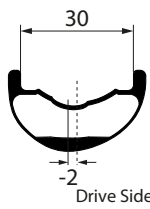
	MODÈLE	MATÉRIAU	TAILLE	TYPE DE JANTE	TYPE DE FREIN	TUBELESS	LARGEUR INTERNE	DÉPORT	TROUS DE RAYON DIRECTIONNELS	TROUS DE RAYON	ERD	ETRTO	RACCORD	LARGEUR DE FOND TUBELESS	VAVLE	PNEUS COMPATIBLES	PRESSION MAXIMALE	PROFIL	
JANTES	JANTE AVANT	MP10-F-29-28H	Carbone	29"	Chambre à air sans crochet	Disque	OUI	30 mm	2 mm	OUI	28	611 mm	622 x 30TSS	—	30 mm	44 mm	2,05"-2,8"	**	
	JANTE ARRIÈRE	MP10-R-29-28H	Carbone	29"	Chambre à air sans crochet	Disque	OUI	30 mm	-2 mm	OUI	28	607,6 mm	622 x 30TSS	—	30 mm	44 mm	2,05"-2,8"	**	

	No. SPOKES	MODEL	DRIVE SIDE SPOKE PATTERN	NON-DRIVE SIDE SPOKE PATTERN	DRIVE SIDE SPOKE LENGTH	NON-DRIVE SIDE SPOKE LENGTH	DRIVE SIDE ASSEMBLY TENSION	DISC SIDE ASSEMBLY TENSION	LEADING SPOKE DRIVE SIDE	TRAILING SPOKE DRIVE SIDE	LEADING SPOKE NON-DRIVE SIDE	TRAILING SPOKE NON-DRIVE SIDE
RAYONS	28	Sapim D-Sprint Butted 14G (2 mm) coudé	3 rayons croisés	3 rayons croisés	298 mm	297 mm	—	1 200 N	Extérieur	Intérieur	Extérieur	Intérieur
	28	Sapim D-Sprint Butted 14G (2 mm) coudé	3 rayons croisés	3 rayons croisés	294 mm	295 mm	1300 N	—	Intérieur	Extérieur	Extérieur	Intérieur

MOYEUR	MODEL	SPACING (OLD)	AXLE	DISC TYPE	SPOKES	FREEHUB BODY	FREEHUB MECHANISM	EMBOUTS	MODEL	MEASUREMENTS	SPOKE NIPPLE WASHERS	POIDS	ROUE	POIDS	USE
MOYEU AVANT	DT SWISS 350 Classic CL	Boost 110 mm	Thru axle 15mm	Verrouillage central	28 coudé	—	—	AVANT	Sapim Brass Polyax	2 x 14 mm (14G)	Non	700 gr +/-5 %	AVANT	700 gr +/-5 %	<b>ASTM Condition 3</b> (cf. manuel d'utilisateur) Poids maximal du système (vélo + cycliste + équipement) = <b>110 kg.</b>
MOYEU ARRIÈRE	DT SWISS 350 Classic CL	Boost 148 mm	Thru axle 12 mm	Verrouillage central	28 coudé	Sram XD ou Shimano Microspline	Ratchet 36	ARRIÈRE	Sapim Brass Polyax	2 x 14 mm (14G)	Non	830 gr +/-5 %	ARRIÈRE	830 gr +/-5 %	

\*\* Pour connaître la pression des pneus maximale, reportez-vous au manuel du propriétaire ou à l'autocollant qui se trouve sur la roue.

[Cliquez sur le modèle de moyeu ou de rayon pour accéder aux informations sur les pièces détachées](#)

## MOUNTAIN PERFORMANCE (MP)

## MP30 TEAM (à partir de l'année-modèle 2025)

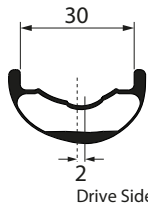
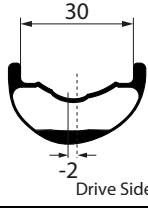
	MODÈLE	MATÉRIAU	TAILLE	TYPE DE JANTE	TYPE DE FREIN	TUBELESS	LARGEUR INTERNE	DÉPORT	TROUS DE RAYON DIRECTIONNELS	TROUS DE RAYON	ERD	ETRTO	RACCORD	LARGEUR DE FOND TUBELESS	VAVLE	PNEUS COMPATIBLES	PRESSION MAXIMALE	PROFIL	
JANTES	JANTE AVANT	MP10-F-29-28H	Carbone	29"	Chambre à air sans crochet	Disque	OUI	30 mm	2 mm	OUI	28	611 mm	622 x 30TSS	—	30 mm	44 mm	2,05"-2,8"	**	
	JANTE ARRIÈRE	MP10-R-29-28H	Carbone	29"	Chambre à air sans crochet	Disque	OUI	30 mm	-2 mm	OUI	28	607,6 mm	622 x 30TSS	—	30 mm	44 mm	2,05"-2,8"	**	

	No. SPOKES	MODEL	DRIVE SIDE SPOKE PATTERN	NON-DRIVE SIDE SPOKE PATTERN	DRIVE SIDE SPOKE LENGTH	NON-DRIVE SIDE SPOKE LENGTH	DRIVE SIDE ASSEMBLY TENSION	DISC SIDE ASSEMBLY TENSION	
RAYONS	AVANT	28	Sapim Sprint SP* Butted 2,0/1,7/2,0	3 rayons croisés	3 rayons croisés	305 mm	305 mm	—	1 200 N
	ARRIÈRE	28	Sapim Sprint SP* Butted 2,0/1,7/2,0	3 rayons croisés	3 rayons croisés	303 mm	303 mm	1300 N	—

MOYEUX	MODEL	SPACING (OLD)	AXLE	DISC TYPE	SPOKES	FREEHUB BODY	FREEHUB MECHANISM	EMBOUITS	MODEL	MEASUREMENTS	SPOKE NIPPLE WASHERS	POIDS	ROUE	USE
	MOYEU AVANT	OQUO TEAM DT 350 INSIDE	Boost 110 mm	Thru axle 15mm	Verrouillage central	28 SP*	—		—	AVANT	Sapim Alloy Double Square			
MOYEU ARRIÈRE	OQUO TEAM DT 350 INSIDE	Boost 148 mm	Thru axle 12 mm	Verrouillage central	28 SP*	Sram XD ou Shimano Microspline	DT Swiss Ratchet 10° / 36	ARRIÈRE	Sapim Alloy Double Square	2 x 18 mm (14G)	Non	810 g +/-5 %		

\*SP : Straightpull

\*\* Pour connaître la pression des pneus maximale, reportez-vous au manuel du propriétaire ou à l'autocollant qui se trouve sur la roue.

Cliquez sur le modèle de moyeu ou de rayon pour accéder aux informations sur les pièces détachées

## MOUNTAIN PERFORMANCE (MP)

## MP28 PRO (jusqu'à l'année-modèle 2023)

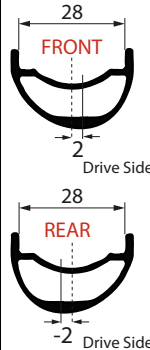
	MODÈLE	MATÉRIAU	TAILLE	TYPE DE JANTE	TYPE DE FREIN	TUBELESS	LARGEUR INTERNE	DÉPORT	TROUS DE RAYON DIRECTIONNELS	TROUS DE RAYON	ERD	ETRTO	RACCORD	LARGEUR DE FOND TUBELESS	VAVLE	PNEUS COMPATIBLES	PRESSION MAXIMALE	PROFIL	
JANTES	AVANT/ARRIÈRE	MP30-B-29-28H	Aluminium AL6061	29"	Chambre à air sans crochet	Disque	OUI	28 mm	2 mm	OUI	28	600 mm	622 x 28TSS	À manchon	28 mm	40 mm	2"-2,55"	**	

	No. SPOKES	MODEL	DRIVE SIDE SPOKE PATTERN	NON-DRIVE SIDE SPOKE PATTERN	DRIVE SIDE SPOKE LENGTH	NON-DRIVE SIDE SPOKE LENGTH	DRIVE SIDE ASSEMBLY TENSION	DISC SIDE ASSEMBLY TENSION	LEADING SPOKE DRIVE SIDE	TRAILING SPOKE DRIVE SIDE	LEADING SPOKE NON-DRIVE SIDE	TRAILING SPOKE NON-DRIVE SIDE
RAYONS	28	Sapim Race Butted 14G (2 mm) coudé	3 rayons croisés	3 rayons croisés	298 mm	297 mm	—	1 200 N	Extérieur	Intérieur	Extérieur	Intérieur
	28	Sapim Race Butted 14G (2 mm) coudé	3 rayons croisés	3 rayons croisés	296 mm	297 mm	1 200 N	—	Intérieur	Extérieur	Extérieur	Intérieur

	MODEL	SPACING (OLD)	AXLE	DISC TYPE	SPOKES	FREEHUB BODY	FREEHUB MECHANISM		MODEL	MEASUREMENTS	SPOKE NIPPLE WASHERS	ROUE	POIDS	<b>USE</b> <b>ASTM Condition 4</b> (cf. manuel d'utilisateur) Poids maximal du système (vélo + cycliste + équipement) = <b>110 kg.</b>	
MOYEU	MOYEU AVANT	DT SWISS 350 Classic CL	Boost 110 mm	Thru axle 15mm	Verrouillage central	28 coudé	—	—	AVANT	Sapim Brass Polyax	2 x 14 mm (14G)	Non	AVANT		850 gr +/- 5 %
	MOYEU ARRIÈRE	DT SWISS 350 Classic CL	Boost 148 mm	Thru axle 12 mm	Verrouillage central	28 coudé	Sram XD Shimano Microspline Shimano HG	Ratchet 36	ARRIÈRE	Sapim Brass Polyax	2 x 14 mm (14G)	Non	ARRIÈRE		955 gr +/- 5 %

\*\* Pour connaître la pression des pneus maximale, reportez-vous au manuel du propriétaire ou à l'autocollant qui se trouve sur la roue.

[Cliquez sur le modèle de moyeu ou de rayon pour accéder aux informations sur les pièces détachées](#)

## MOUNTAIN PERFORMANCE (MP)

## MP28 PRO (à partir de l'année-modèle 2024)

	MODÈLE	MATÉRIAU	TAILLE	TYPE DE JANTE	TYPE DE FREIN	TUBELESS	LARGEUR INTERNE	DÉPORT	TROUS DE RAYON DIRECTIONNELS	TROUS DE RAYON	ERD	ETRTO	RACCORD	LARGEUR DE FOND TUBELESS	VAVLE	PNEUS COMPATIBLES	PRESSION MAXIMALE	PROFIL	
JANTES	AVANT / ARRIÈRE	MP31-B-29-28H	Aluminium AL6061	29"	Chambre à air sans crochet	Disque	OUI	28 mm	2 mm	OUI	28	600 mm	622 x 28TSS	À manchon	28 mm	40 mm	2"-2,55"	**	

	No. SPOKES	MODEL	DRIVE SIDE SPOKE PATTERN	NON-DRIVE SIDE SPOKE PATTERN	DRIVE SIDE SPOKE LENGTH	NON-DRIVE SIDE SPOKE LENGTH	DRIVE SIDE ASSEMBLY TENSION	DISC SIDE ASSEMBLY TENSION	LEADING SPOKE DRIVE SIDE	TRAILING SPOKE DRIVE SIDE	LEADING SPOKE NON-DRIVE SIDE	TRAILING SPOKE NON-DRIVE SIDE	
RAYONS	AVANT	28	Sapim Race Butted 14G (2 mm) coudé	3 rayons croisés	3 rayons croisés	297 mm	296 mm	—	1 200 N	Extérieur	Intérieur	Extérieur	Intérieur
	ARRIÈRE	28	Sapim Race Butted 14G (2 mm) coudé	3 rayons croisés	3 rayons croisés	296 mm	296 mm	1 200 N	—	Intérieur	Extérieur	Extérieur	Intérieur

	MODEL	SPACING (OLD)	AXLE	DISC TYPE	SPOKES	FREEHUB BODY	FREEHUB MECHANISM		MODEL	MEASUREMENTS	SPOKE NIPPLE WASHERS		ROUE	POIDS		
MOYEU AVANT	DT SWISS 370 Classic IS	Boost 110 mm	Thru axle 15mm	6 boulons	28 coudé	—	—	EMBOUTS	AVANT	Sapim Brass Polyax	2 x 14 mm (14G)	Non	POIDS	AVANT	890 gr +/- 5 %	<b>ASTM Condition 4</b> (cf. manuel d'utilisateur) Poids maximal du système (vélo + cycliste + équipement) = <b>110 kg.</b>
MOYEU ARRIÈRE	DT SWISS 370 Classic IS	Boost 110 mm	Thru axle 15mm	6 boulons	28 coudé	Sram XD Shimano Microspline	Ratchet LN 18		ARRIÈRE	Sapim Brass Polyax	2 x 14 mm (14G)	Non		ARRIÈRE	1 040 gr +/- 5 %	

\*\* Pour connaître la pression des pneus maximale, reportez-vous au manuel du propriétaire ou à l'autocollant qui se trouve sur la roue.

[Cliquez sur le modèle de moyeu ou de rayon pour accéder aux informations sur les pièces détachées](#)

## MOUNTAIN CONTROL (MC)

## MC32 LTD (jusqu'à l'année-modèle 2025)

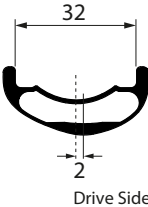
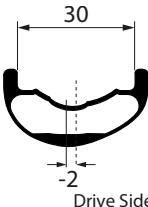
	MODÈLE	MATÉRIAU	TAILLE	TYPE DE JANTE	TYPE DE FREIN	TUBELESS	LARGEUR INTERNE	DÉPORT	TROUS DE RAYON DIRECTIONNELS	TROUS DE RAYON	ERD	ETRTO	RACCORD	LARGEUR DE FOND TUBELESS	VAVLE	PNEUS COMPATIBLES	PRESSION MAXIMALE	PROFIL
JANTES JANTE AVANT	MC10-F-29-28H	Carbone	29"	Chambre à air sans crochet	Disque	OUI	32 mm	2 mm	OUI	28	604,26-mm	622 x 32TSS	—	32 mm	44 mm	2,4"-2,8"	**	
JANTES JANTE ARRIÈRE	MC10-R-29-32H	Carbone	29"	Chambre à air sans crochet	Disque	OUI	30 mm	-2 mm	OUI	32	599,86-mm	622 x 30TSS	—	30 mm	44 mm 57 mm sur l'extension avec aimant dans la valve	2,05"-2,8"	**	

	No. SPOKES	MODEL	DRIVE SIDE SPOKE PATTERN	NON-DRIVE SIDE SPOKE PATTERN	DRIVE SIDE SPOKE LENGTH	NON-DRIVE SIDE SPOKE LENGTH	DRIVE SIDE ASSEMBLY TENSION	DISC SIDE ASSEMBLY TENSION	LEADING SPOKE DRIVE SIDE	TRAILING SPOKE DRIVE SIDE	LEADING SPOKE NON-DRIVE SIDE	TRAILING SPOKE NON-DRIVE SIDE
RAYONS AVANT	28	Sapim D-Sprint Butted, 14G (2 mm) coudé	3 rayons croisés	3 rayons croisés	301 mm	298 mm	—	1 200 N	Extérieur	Intérieur	Extérieur	Intérieur
RAYONS ARRIÈRE	32	Sapim D-Sprint Butted, 14G (2 mm) coudé	3 rayons croisés	3 rayons croisés	292 mm	292 mm	1300 N	—	Intérieur	Extérieur	Extérieur	Intérieur

MOYEUX	MODEL	SPACING (OLD)	AXLE	DISC TYPE	SPOKES	FREEHUB BODY	FREEHUB MECHANISM	EMBOUTS	MODEL	MEASUREMENTS	SPOKE NIPPLE WASHERS	POIDS	ROUE	POIDS	USE
MOYEUX AVANT	DT SWISS 350 Classic IS	Boost 110 mm	Thru axle 15mm	6 boulons	28 coudé	—	—	AVANT	Sapim Brass Polyax	2 x 14 mm (14G)	Non	860 g +/- 5 %	AVANT	860 g +/- 5 %	<b>ASTM Condition 5</b> (cf. manuel d'utilisateur) Poids maximal du système (vélo + cycliste + équipement) = <b>135 kg.</b>
MOYEUX ARRIÈRE	DT SWISS 350 Classic IS	Boost 148 mm	Thru axle 12mm	6 boulons	32 coudé	Sram XD Shimano MS	Ratchet 36	ARRIÈRE	Sapim Brass Polyax	2 x 14 mm (14G)	Non	1 042 gr +/- 5 %	ARRIÈRE	1 042 gr +/- 5 %	

\*\* Pour connaître la pression des pneus maximale, reportez-vous au manuel du propriétaire ou à l'autocollant qui se trouve sur la roue.

[Cliquez sur le modèle de moyeu ou de rayon pour accéder aux informations sur les pièces détachées](#)

## MOUNTAIN CONTROL (MC)

## MC32 LTD (à partir de l'année-modèle 2026)

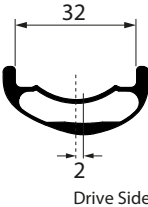
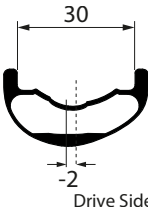
	MODÈLE	MATÉRIAU	TAILLE	TYPE DE JANTE	TYPE DE FREIN	TUBELESS	LARGEUR INTERNE	DÉPORT	TROUS DE RAYON DIRECTIONNELS	TROUS DE RAYON	ERD	ETRTO	RACCORD	LARGEUR DE FOND TUBELESS	VAVLE	PNEUS COMPATIBLES	PRÉSSION MAXIMALE	PROFIL	
JANTES	JANTE AVANT	MC10-F-29-28H	Carbone	29"	Chambre à air sans crochet	Disque	OUI	32 mm	2 mm	OUI	28	604,26-mm	622 x 32TSS	—	32 mm	44 mm	2,4"-2,8"	**	
	JANTE ARRIÈRE	MC10-R-29-32H	Carbone	29"	Chambre à air sans crochet	Disque	OUI	30 mm	-2 mm	OUI	32	599,86-mm	622 x 30TSS	—	30 mm	44 mm sur l'extension avec aimant dans la valve	2,05"-2,8"	**	

	No. SPOKES	MODEL	DRIVE SIDE SPOKE PATTERN	NON-DRIVE SIDE SPOKE PATTERN	DRIVE SIDE SPOKE LENGTH	NON-DRIVE SIDE SPOKE LENGTH	DRIVE SIDE ASSEMBLY TENSION	DISC SIDE ASSEMBLY TENSION	LEADING SPOKE DRIVE SIDE	TRAILING SPOKE DRIVE SIDE	LEADING SPOKE NON-DRIVE SIDE	TRAILING SPOKE NON-DRIVE SIDE
RAYONS	28	Sapim Sprint Butted, 14G (2 mm) Coudé	3 rayons croisés	3 rayons croisés	299 mm	299 mm	—	1 200 N	Extérieur	Intérieur	Extérieur	Intérieur
	32	Sapim Race Butted 14G (2 mm) Coudé	3 rayons croisés	3 rayons croisés	291 mm	291 mm	1300 N	—	Intérieur	Extérieur	Extérieur	Intérieur

MOYEU	MODEL	SPACING (OLD)	AXLE	DISC TYPE	SPOKES	FREEHUB BODY	FREEHUB MECHANISM	EMBOUITS	MODEL	MEASUREMENTS	SPOKE NIPPLE WASHERS	POIDS	ROUE	POIDS	USE
	MOYEU AVANT	OQUO LTD DT 350 INSIDE	Boost 110 mm	Thru axle 15mm	6 boulons	28 coudé	—		—	AVANT	Sapim Brass Polyax				
MOYEU ARRIÈRE	OQUO LTD DT 350 DEG INSIDE	Boost 148 mm	Thru axle 12mm	6 boulons	32 coudé	Sram XD Shimano MS	Ratchet DEG 72	ARRIÈRE	Sapim Brass Polyax	2 x 14 mm (14G)	Non	ARRIÈRE	1 042 gr +/- 5 %		

\*\* Pour connaître la pression des pneus maximale, reportez-vous au manuel du propriétaire ou à l'autocollant qui se trouve sur la roue.

[Cliquez sur le modèle de moyeu ou de rayon pour accéder aux informations sur les pièces détachées](#)

## MOUNTAIN CONTROL (MC)

## MC32 LTD POWER (jusqu'à l'année-modèle 2023)

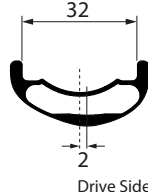
JANTES	MODÈLE	MATÉRIAU	TAILLE	TYPE DE JANTE	TYPE DE FREIN	TUBELESS	LARGEUR INTERNE	DÉPORT	TROUS DE RAYON DIRECTIONNELS	TROUS DE RAYON	ERD	ETRTO	RACCORD	LARGEUR DE FOND TUBELESS	VAVLE	PNEUS COMPATIBLES	PRESSION MAXIMALE	PROFIL
JANTE ARRIÈRE	MC10-R-29-32H	Carbone	29"	Chambre à air sans crochet	Disque	OUI	30 mm	-2 mm	OUI	32	599,86 mm	622 x 30TSS	—	30 mm	44 mm sur l'extension avec aimant dans la valve	2,05"-2,8"	**	 Drive Side

RAYONS	No. SPOKES	MODEL	DRIVE SIDE SPOKE PATTERN	NON-DRIVE SIDE SPOKE PATTERN	DRIVE SIDE SPOKE LENGTH	NON-DRIVE SIDE SPOKE LENGTH	DRIVE SIDE ASSEMBLY TENSION	DISC SIDE ASSEMBLY TENSION	LEADING SPOKE DRIVE SIDE	TRAILING SPOKE DRIVE SIDE	LEADING SPOKE NON-DRIVE SIDE	TRAILING SPOKE NON-DRIVE SIDE
ARRIÈRE	32	Sapim E-Light. Butted 14G (2 mm) coudé	3 rayons croisés	3 rayons croisés	292 mm	294 mm	1300 N	—	Intérieur	Extérieur	Extérieur	Intérieur

MOYEUX	MODEL	SPACING (OLD)	AXLE	DISC TYPE	SPOKES	FREEHUB BODY	FREEHUB MECHANISM	EMBOUTS	MODEL	MEASUREMENTS	SPOKE NIPPLE WASHERS	POIDS	ROUE	POIDS	USE
MOYEUX ARRIÈRE	DT SWISS 350 Hybrid Classic IS modèle jusqu'à l'année-modèle 2023	Boost 148 mm	Thru axle 12mm	6 boulons	32	Sram XD Shimano MS	Ratchet 24	ARRIÈRE	Sapim Brass Polyax	2 x 14 mm (14G)	Non	ARRIÈRE	1 042 gr +/- 5 %	ASTM Condition 5 (cf. manuel d'utilisateur) Poids maximal du système (vélo + cycliste + équipement) = <b>135 kg.</b>	

\*\* Pour connaître la pression des pneus maximale, reportez-vous au manuel du propriétaire ou à l'autocollant qui se trouve sur la roue.

[Cliquez sur le modèle de moyeu ou de rayon pour accéder aux informations sur les pièces détachées](#)

## MOUNTAIN CONTROL (MC)

## MC32 LTD POWER (à partir de l'année-modèle 2024)

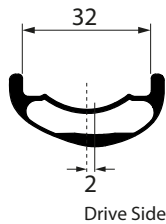
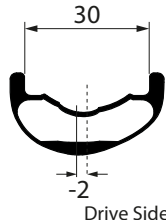
	MODÈLE	MATÉRIAU	TAILLE	TYPE DE JANTE	TYPE DE FREIN	TUBELESS	LARGEUR INTERNE	DÉPORT	TROUS DE RAYON DIRECTIONNELS	TROUS DE RAYON	ERD	ETRTO	RACCORD	LARGEUR DE FOND TUBELESS	VAVLE	PNEUS COMPATIBLES	PRESSION MAXIMALE	PROFIL
JANTES JANTE AVANT	MC10-F-29-28H	Carbone	29"	Chambre à air sans crochet	Disque	OUI	32 mm	2 mm	OUI	28	604,26-mm	622 x 32TSS	—	32 mm	44 mm	2,4"-2,8"	**	
JANTE ARRIÈRE	MC10-R-29-32H	Carbone	29"	Chambre à air sans crochet	Disque	OUI	30 mm	-2 mm	OUI	32	599,86-mm	622 x 30TSS	—	30 mm	44 mm sur l'extension avec aimant dans la valve	2,05"-2,8"	**b	

	No. SPOKES	MODEL	DRIVE SIDE SPOKE PATTERN	NON-DRIVE SIDE SPOKE PATTERN	DRIVE SIDE SPOKE LENGTH	NON-DRIVE SIDE SPOKE LENGTH	DRIVE SIDE ASSEMBLY TENSION	DISC SIDE ASSEMBLY TENSION	LEADING SPOKE DRIVE SIDE	TRAILING SPOKE DRIVE SIDE	LEADING SPOKE NON-DRIVE SIDE	TRAILING SPOKE NON-DRIVE SIDE
RAYONS AVANT	28	Sapim E-Light. Butted 14G (2 mm) coudé	3 rayons croisés	3 rayons croisés	299 mm	298 mm	—	1300 N	Extérieur	Intérieur	Extérieur	Intérieur
ARRIÈRE	32	Sapim E-Light. Butted 14G (2 mm) coudé	3 rayons croisés	3 rayons croisés	291 mm	292 mm	1300 N	—	Intérieur	Extérieur	Extérieur	Intérieur

	MODEL	SPACING (OLD)	AXLE	DISC TYPE	SPOKES	FREEHUB BODY	FREEHUB MECHANISM		MODEL	MEASUREMENTS	SPOKE NIPPLE WASHERS		ROUE	POIDS	
MOYEU AVANT	DT SWISS 350 Hybrid Classic IS modèle à partir de l'année-modèle 2024	Boost 110 mm	Thru axle 15mm	6 boulons	28	—	—	EMBOUITS AVANT	Sapim Brass Polyax	2 x 14 mm (14G)	Non	POIDS AVANT	910 gr +/- 5 %	USE ASTM Condition 5 (cf. manuel d'utilisateur) Poids maximal du système (vélo + cycliste + équipement) = <b>135 kg.</b>	
MOYEU ARRIÈRE	DT SWISS 350 Hybrid Classic IS modèle à partir de l'année-modèle 2024	Boost 148 mm	Thru axle 12mm	6 boulons	32	Sram XD Shimano MS	Ratchet 24	ARRIÈRE	Sapim Brass Polyax	2 x 14 mm (14G)	Non	ARRIÈRE	1 056 gr +/- 5 %		

\*\* Pour connaître la pression des pneus maximale, reportez-vous au manuel du propriétaire ou à l'autocollant qui se trouve sur la roue.

[Cliquez sur le modèle de moyeu ou de rayon pour accéder aux informations sur les pièces détachées](#)

## MOUNTAIN CONTROL (MC)

## MC32 TEAM (jusqu'à l'année-modèle 2024)

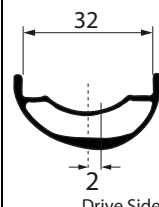
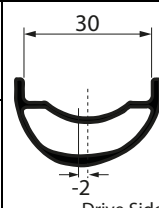
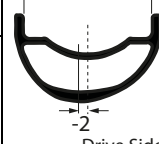
	MODÈLE	MATÉRIAU	TAILLE	TYPE DE JANTE	TYPE DE FREIN	TUBELESS	LARGEUR INTERNE	DÉPORT	TROUS DE RAYON DIRC.	TROUS DE RAYON	ERD	ETRTO	RACCORD	LARGEUR DE FOND TUBELESS	VAVLE	PNEUS COMPATIBLES	PRESSION MAXIMALE	PROFIL	
JANTES	JANTE AVANT 29"	MC30-F-29-28H	Aluminium AL6061	29"	Chambre à air sans crochet	Disque	OUI	32 mm	2 mm	OUI	28	604 mm	622 x 32TSS	À manchon	32 mm	44 mm	2,4"-2,8"	**	
	JANTE ARRIÈRE 29"	MC30-R-29-32H	Aluminium AL6061	29"	Chambre à air sans crochet	Disque	OUI	30 mm	-2 mm	OUI	32	600 mm	622 x 30TSS	À manchon	30 mm	44 mm 57 mm on Wild with magnet in valve	2,05"-2,8"	**	
	JANTE ARRIÈRE 27,5"	MC31-R-27-32H	Aluminium AL6061	27,5"	Chambre à air sans crochet	Disque	OUI	30 mm	-2 mm	OUI	32	561,6 mm	584 x 30TSS	À manchon	30 mm	44 mm 57 mm on Wild with magnet in valve	2,05"-2,8"	**	

	No. SPOKES	MODEL	DRIVE SIDE SPOKE PATTERN	NON-DRIVE SIDE SPOKE PATTERN	DRIVE SIDE SPOKE LENGTH	NON-DRIVE SIDE SPOKE LENGTH	DRIVE SIDE ASSEMBLY TENSION	DISC SIDE ASSEMBLY TENSION	LEADING SPOKE DRIVE SIDE	TRAILING SPOKE DRIVE SIDE	LEADING SPOKE NON-DRIVE SIDE	TRAILING SPOKE NON-DRIVE SIDE	
RAYONS	AVANT 29"	28	Sapim D-Sprint Butted. 14G (2 mm). Coudé	3 rayons croisés	3 rayons croisés	299 mm	297 mm	—	1 200 N	Extérieur	Intérieur	Extérieur	Intérieur
	ARRIÈRE 29"	32	Sapim Race Butted. 14G (2 mm). Coudé	3 rayons croisés	3 rayons croisés	291 mm	291 mm	1 200 N	—	Intérieur	Extérieur	Extérieur	Intérieur
	ARRIÈRE 27,5"	32	Sapim Race Butted. 14G (2 mm). Coudé	3 rayons croisés	3 rayons croisés	271 mm	271 mm	1 200 N	—	Intérieur	Extérieur	Extérieur	Intérieur

MOYEURS	MODEL	SPACING (OLD)	AXLE	DISC TYPE	SPOKES	FREEHUB BODY	FREEHUB MECHANISM	EMBOUITS	MODEL	MEASUREMENTS	SPOKE NIPPLE WASHERS	POIDS	ROUE	POIDS	USE			
	AVANT 29"	DT SWISS 350 Classic IS	Boost 110 mm	Thru axle 15mm	6 boulons	28 coudé	—		—	AVANT 29"	Sapim Brass Polyax		2 x 14 mm (14G)			Non	AVANT 29"	898 gr +/- 5 %
	ARRIÈRE 29"	DT SWISS 350 Classic IS	Boost 148 mm	Thru axle 12 mm	6 boulons	32 coudé	Sram XD ou Shimano MS		Ratchet 36	ARRIÈRE 29"	Sapim Brass Polyax		2 x 14 mm (14G)			Non	ARRIÈRE 29"	1 046 gr +/- 5 %
ARRIÈRE 27,5"	DT SWISS 350 Classic IS	Boost 148 mm	Thru axle 12 mm	6 boulons	32 coudé	Sram XD ou Shimano MS	Ratchet 36	ARRIÈRE 27,5"	Sapim Brass Polyax	2 x 14 mm (14G)	Non	ARRIÈRE 27,5"	1 010 gr +/- 5 %					

**ASTM Condition 5**  
(cf. manuel d'utilisateur)  
Poids maximal du système  
(vélo + cycliste + équipement)  
= **135 kg.**

\*\* Pour connaître la pression des pneus maximale, reportez-vous au manuel du propriétaire ou à l'autocollant qui se trouve sur la roue.

[Cliquez sur le modèle de moyeu ou de rayon pour accéder aux informations sur les pièces détachées](#)

## MOUNTAIN CONTROL (MC)

## MC32 TEAM (Année-modèle 2025)

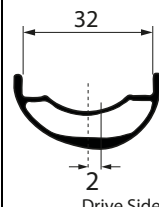
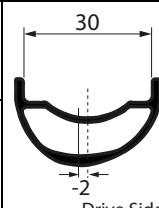
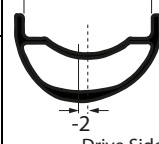
	MODÈLE	MATÉRIAU	TAILLE	TYPE DE JANTE	TYPE DE FREIN	TUBELESS	LARGEUR INTERNE	DÉPORT	TROUS DE RAYON DIREC.	TROUS DE RAYON	ERD	ETRTO	RACCORD	LARGEUR DE FOND TUBELESS	VAVLE	PNEUS COMPATIBLES	PRESSION MAXIMALE	PROFIL	
JANTES	JANTE AVANT 29"	MC36-F-29-28 trous	Aluminium AL6061	29"	Chambre à air sans crochet	Disque	OUI	32 mm	2 mm	OUI	28	612,3 mm	622 x 32TSS	À manchon	32 mm	44 mm	2,4"-2,8"	**	
	JANTE ARRIÈRE 29"	MC36-R-29-32 trous	Aluminium AL6061	29"	Chambre à air sans crochet	Disque	OUI	30 mm	-2 mm	OUI	32	610,9 mm	622 x 30TSS	À manchon	30 mm	44 mm 57 mm on Wild with magnet in valve	2,05"-2,8"	**	
	JANTE ARRIÈRE 27,5"	MC37-R-27-32 trous	Aluminium AL6061	27,5"	Chambre à air sans crochet	Disque	OUI	30 mm	-2 mm	OUI	32	572,9 mm	584 x 30TSS	À manchon	30 mm	44 mm 57 mm on Wild with magnet in valve	2,05"-2,8"	**	

	No. SPOKES	MODEL	DRIVE SIDE SPOKE PATTERN	NON-DRIVE SIDE SPOKE PATTERN	DRIVE SIDE SPOKE LENGTH	NON-DRIVE SIDE SPOKE LENGTH	DRIVE SIDE ASSEMBLY TENSION	DISC SIDE ASSEMBLY TENSION	LEADING SPOKE DRIVE SIDE	TRAILING SPOKE DRIVE SIDE	LEADING SPOKE NON-DRIVE SIDE	TRAILING SPOKE NON-DRIVE SIDE	
RAYONS	AVANT 29"	28	Sapim D-Light Butted. 14G (2 mm). Coudé	3 rayons croisés	3 rayons croisés	302 mm	300 mm	—	1300 N	Extérieur	Intérieur	Extérieur	Intérieur
	ARRIÈRE 29"	32	Sapim Sprint Butted. 14G (2 mm). Coudé	3 rayons croisés	3 rayons croisés	295 mm	295 mm	1300 N	—	Intérieur	Extérieur	Extérieur	Intérieur
	ARRIÈRE 27,5"	32	Sapim Sprint Butted. 14G (2 mm). Coudé	3 rayons croisés	3 rayons croisés	276 mm	276 mm	1300 N	—	Intérieur	Extérieur	Extérieur	Intérieur

MOYEURS	MODEL	SPACING (OLD)	AXLE	DISC TYPE	SPOKES	FREEHUB BODY	FREEHUB MECHANISM	EMBOUITS	MODEL	MEASUREMENTS	SPOKE NIPPLE WASHERS	POIDS	ROUE	POIDS	USE			
	AVANT 29"	DT SWISS 350 Classic IS	Boost 110 mm	Thru axle 15mm	6 boulons	28 coudé	—		—	AVANT 29"	Sapim Alloy Double Square		2 x 18 mm (14G)			Non	AVANT 29"	970 g +/- 5 %
	ARRIÈRE 29"	DT SWISS 350 Classic IS	Boost 148 mm	Thru axle 12 mm	6 boulons	32 coudé	Sram XD ou Shimano MS		Ratchet 36	ARRIÈRE 29"	Sapim Alloy Double Square		2 x 18 mm (14G)			Non	ARRIÈRE 29"	1108 g +/- 5 %
ARRIÈRE 27,5"	DT SWISS 350 Classic IS	Boost 148 mm	Thru axle 12 mm	6 boulons	32 coudé	Sram XD ou Shimano MS	Ratchet 36	ARRIÈRE 27,5"	Sapim Alloy Double Square	2 x 18 mm (14G)	Non	ARRIÈRE 27,5"	1055 g +/- 5 %					

**ASTM Condition 5**  
(cf. manuel d'utilisateur)  
Poids maximal du système  
(vélo + cycliste + équipement)  
= **135 kg.**

\*\* Pour connaître la pression des pneus maximale, reportez-vous au manuel du propriétaire ou à l'autocollant qui se trouve sur la roue.

[Cliquez sur le modèle de moyeu ou de rayon pour accéder aux informations sur les pièces détachées](#)

## MOUNTAIN CONTROL (MC)

## MC32 TEAM (à partir de l'année-modèle 2026)

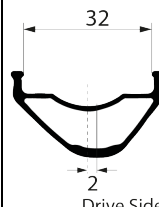
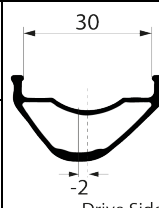
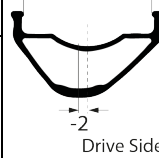
	MODÈLE	MATÉRIAU	TAILLE	TYPE DE JANTE	TYPE DE FREIN	TUBELESS	LARGEUR INTERNE	DÉPORT	TROUS DE RAYON DIREC.	TROUS DE RAYON	ERD	ETRTO	RACCORD	LARGEUR DE FOND TUBELESS	VAVLE	PNEUS COMPATIBLES	PRESSION MAXIMALE	PROFIL	
JANTES	JANTE AVANT 29"	MC36-F-29-28 trous	Aluminium AL6061	29"	Chambre à air Minihook	Disque	OUI	32 mm	2 mm	OUI	28	612,3 mm	622 x 32TSS	À manchon	32 mm	44 mm	2,4"-2,8"	**	
	JANTE ARRIÈRE 29"	MC36-R-29-32 trous	Aluminium AL6061	29"	Chambre à air Minihook	Disque	OUI	30 mm	-2 mm	OUI	32	610,9 mm	622 x 30TSS	À manchon	30 mm	44 mm 57 mm on Wild with magnet in valve	2,05"-2,8"	**	
	JANTE ARRIÈRE 27,5"	MC37-R-27-32 trous	Aluminium AL6061	27,5"	Chambre à air Minihook	Disque	OUI	30 mm	-2 mm	OUI	32	572,9 mm	584 x 30TSS	À manchon	30 mm	44 mm 57 mm on Wild with magnet in valve	2,05"-2,8"	**	

	No. SPOKES	MODEL	DRIVE SIDE SPOKE PATTERN	NON-DRIVE SIDE SPOKE PATTERN	DRIVE SIDE SPOKE LENGTH	NON-DRIVE SIDE SPOKE LENGTH	DRIVE SIDE ASSEMBLY TENSION	DISC SIDE ASSEMBLY TENSION	LEADING SPOKE DRIVE SIDE	TRAILING SPOKE DRIVE SIDE	LEADING SPOKE NON-DRIVE SIDE	TRAILING SPOKE NON-DRIVE SIDE	
RAYONS	AVANT 29"	28	Sapim D-Light Butted. 14G (2 mm). Coudé	3 rayons croisés	3 rayons croisés	298 mm	297 mm	—	1300 N	Extérieur	Intérieur	Extérieur	Intérieur
	ARRIÈRE 29"	32	Sapim Sprint Butted. 14G (2 mm). Coudé	3 rayons croisés	3 rayons croisés	291 mm	291 mm	1300 N	—	Intérieur	Extérieur	Extérieur	Intérieur
	ARRIÈRE 27,5"	32	Sapim Sprint Butted. 14G (2 mm). Coudé	3 rayons croisés	3 rayons croisés	272 mm	272 mm	1300 N	—	Intérieur	Extérieur	Extérieur	Intérieur

MOYEURS	MODEL	SPACING (OLD)	AXLE	DISC TYPE	SPOKES	FREEHUB BODY	FREEHUB MECHANISM	EMBOÜTS	MODEL	MEASUREMENTS	SPOKE NIPPLE WASHERS	POIDS	ROUE	POIDS	USE
	AVANT 29"	ARRIÈRE 29"	ARRIÈRE 27,5"	AVANT 29"	ARRIÈRE 29"	ARRIÈRE 27,5"	AVANT 29"		ARRIÈRE 29"	ARRIÈRE 27,5"					
	OQUO LTD DT 350 INSIDE	Boost 110 mm	Thru axle 15mm	6 boulons	28 coudé	—	—		Sapim Alloy Double Square	2 x 18 mm (14G)	Non		AVANT 29"	950 g +/- 5 %	<b>ASTM Condition 5</b> (cf. manuel d'utilisateur) Poids maximal du système (vélo + cycliste + équipement) = <b>135 kg.</b>
	OQUO LTD DT 350 DEG INSIDE	Boost 148 mm	Thru axle 12 mm	6 boulons	32 coudé	Sram XD ou Shimano MS	Ratchet DEG 72		Sapim Alloy Double Square	2 x 18 mm (14G)	Non		ARRIÈRE 29"	1125 g +/- 5 %	
	OQUO LTD DT 350 DEG INSIDE	Boost 148 mm	Thru axle 12 mm	6 boulons	32 coudé	Sram XD ou Shimano MS	Ratchet DEG 72		Sapim Alloy Double Square	2 x 18 mm (14G)	Non		ARRIÈRE 27,5"	1075 g +/- 5 %	

\*\* Pour connaître la pression des pneus maximale, reportez-vous au manuel du propriétaire ou à l'autocollant qui se trouve sur la roue.

[Cliquez sur le modèle de moyeu ou de rayon pour accéder aux informations sur les pièces détachées](#)

## MOUNTAIN CONTROL (MC)

## MC32 TEAM RALLON DH Année-modèle 2026 (OEM)

## ATTENTION

Ce jeu de roue MC32 TEAM est uniquement disponible sur les ensembles complets de vélo Orbea Rallon DH Année-modèle 2026

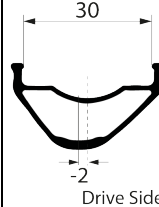
JANTES	MODÈLE	MATÉRIAU	TAILLE	TYPE DE JANTE	TYPE DE FREIN	TUBELESS	LARGEUR INTERNE	DÉPORT	TROUS DE RAYON DIREC.	TROUS DE RAYON	ERD	ETRTO	RACCORD	LARGEUR DE FOND TUBELESS	VAVLE	PNEUS COMPATIBLES	PRESSION MAXIMALE	PROFIL
	JANTE AVANT 29"	MC36-F-29-28 trous	Aluminium AL6061	29"	Chambre à air Minihook	Disque	OUI	32 mm	2 mm	OUI	28	612,3 mm	622 x 32TSS	À manchon	32 mm	44 mm	2,4"-2,8"	**
JANTE ARRIÈRE 27,5"	MC37-R-27-32 trous	Aluminium AL6061	27,5"	Chambre à air Minihook	Disque	OUI	30 mm	-2 mm	OUI	32	572,9 mm	584 x 30TSS	À manchon	30 mm	44 mm 57 mm on Wild with magnet in valve	2,05"-2,8"	**	

RAYONS	No. SPOKES	MODEL	DRIVE SIDE SPOKE PATTERN	NON-DRIVE SIDE SPOKE PATTERN	DRIVE SIDE SPOKE LENGTH	NON-DRIVE SIDE SPOKE LENGTH	DRIVE SIDE ASSEMBLY TENSION	DISC SIDE ASSEMBLY TENSION	LEADING SPOKE DRIVE SIDE	TRAILING SPOKE DRIVE SIDE	LEADING SPOKE NON-DRIVE SIDE	TRAILING SPOKE NON-DRIVE SIDE
	AVANT 29"	28	Sapim Race Butted. 14G (2 mm). Coudé	3 rayons croisés	3 rayons croisés	296 mm	296 mm	—	1300 N	Extérieur	Intérieur	Extérieur
ARRIÈRE 27,5"	32	Sapim Race Butted. 14G (2 mm). Coudé	3 rayons croisés	3 rayons croisés	272 mm	272 mm	1300 N	—	Intérieur	Extérieur	Extérieur	Intérieur

MOYEURS	MODEL	SPACING (OLD)	AXLE	DISC TYPE	SPOKES	FREEHUB BODY	FREEHUB MECHANISM	EMBOUITS	MODEL	MEASUREMENTS	SPOKE NIPPLE WASHERS	POIDS	ROUE	POIDS	USE
	AVANT 29"	DT SWISS 350 Classic IS	Boost 110 mm	Thru axle 20 mm	6 vis	28 coudé	—		—	AVANT 29"	Sapim Brass Polyax		2 x 14 mm (14G)		
ARRIÈRE 27,5"	DT SWISS 350 Classic IS	Boost 148 mm	Thru axle 12 mm	6 vis	32 coudé	Shimano HG	Ratchet 36 SL	ARRIÈRE 27,5"	Sapim Brass Polyax	2 x 14 mm (14G)	Non	ARRIÈRE 27,5"	1055 g +/- 5 %		

**ASTM Condition 5**  
(cf. manuel d'utilisateur)  
Poids maximal du système  
(vélo + cycliste + équipement)  
= **135 kg.**

\*\* Pour connaître la pression des pneus maximale, reportez-vous au manuel du propriétaire ou à l'autocollant qui se trouve sur la roue.

Cliquez sur le modèle de moyeu ou de rayon pour accéder aux informations sur les pièces détachées

## MOUNTAIN CONTROL (MC)

## MC32 TEAM POWER (jusqu'à l'année-modèle 2023)

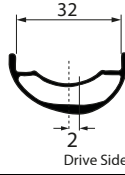
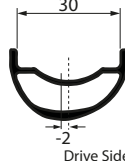
	MODÈLE	MATÉRIAU	TAILLE	TYPE DE JANTE	TYPE DE FREIN	TUBELESS	LARGEUR INTERNE	DÉPORT	TROUS DE RAYON DIRECTIONNELS	TROUS DE RAYON	ERD	ETRTO	RACCORD	LARGEUR DE FOND TUBELESS	VAVLE	PNEUS COMPATIBLES	PRESSION MAXIMALE	PROFIL
JANTES JANTE AVANT	MC31-F-29-32H	Aluminium AL6061	29"	Chambre à air sans crochet	Disque	OUI	32 mm	2 mm	OUI	32	604 mm	622 x 32TSS	À manchon	32 mm	44 mm	2,4"-2,8"	**	
JANTE ARRIÈRE	MC30-R-29-32H	Aluminium AL6061	29"	Chambre à air sans crochet	Disque	OUI	30 mm	-2 mm	OUI	32	600 mm	622 x 30TSS	À manchon	30 mm	44 mm 57 mm on Wild with magnet in valve	2,05"-2,8"	**	

	No. SPOKES	MODEL	DRIVE SIDE SPOKE PATTERN	NON-DRIVE SIDE SPOKE PATTERN	DRIVE SIDE SPOKE LENGTH	NON-DRIVE SIDE SPOKE LENGTH	DRIVE SIDE ASSEMBLY TENSION	DISC SIDE ASSEMBLY TENSION	LEADING SPOKE DRIVE SIDE	TRAILING SPOKE DRIVE SIDE	LEADING SPOKE NON-DRIVE SIDE	TRAILING SPOKE NON-DRIVE SIDE
RAYONS AVANT	32	Sapim E-Light. Butted 14G (2 mm) coudé	3 rayons croisés	3 rayons croisés	294 mm	292 mm	—	1 200 N	Extérieur	Intérieur	Extérieur	Intérieur
ARRIÈRE	32	Sapim E-Light. Butted 14G (2 mm) coudé	3 rayons croisés	3 rayons croisés	291 mm	293 mm	1 200 N	—	Intérieur	Extérieur	Extérieur	Intérieur

	MODEL	SPACING (OLD)	AXLE	DISC TYPE	SPOKES	FREEHUB BODY	FREEHUB MECHANISM		MODEL	MEASUREMENTS	SPOKE NIPPLE WASHERS		ROUE	POIDS	
MOYEUR MOYEU AVANT	DT SWISS 350 Hybrid Classic IS modèle jusqu'à l'année-modèle 2023	Boost 110 mm	Thru axle 15mm	6 boulons	32	—	—	EMBOUTS AVANT	Sapim Brass Polyax	2 x 14 mm (14G)	Non	POIDS AVANT	930 gr +/- 5 %	USE ASTM Condition 5 (cf. manuel d'utilisateur) Poids maximal du système (vélo + cycliste + équipement) = <b>135 kg.</b>	
MOYEU ARRIÈRE	DT SWISS 350 Hybrid Classic IS modèle jusqu'à l'année-modèle 2023	Boost 148 mm	Thru axle 12 mm	6 boulons	32	Sram XD Shimano MS	Ratchet 24	ARRIÈRE	Sapim Brass Polyax	2 x 14 mm (14G)	Non	ARRIÈRE	1 060 gr +/- 5 %		

\*\* Pour connaître la pression des pneus maximale, reportez-vous au manuel du propriétaire ou à l'autocollant qui se trouve sur la roue.

[Cliquez sur le modèle de moyeu ou de rayon pour accéder aux informations sur les pièces détachées](#)

## MOUNTAIN CONTROL (MC)

## MC32 TEAM POWER (Année-modèle 2024)

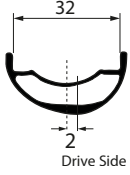
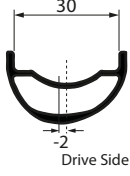
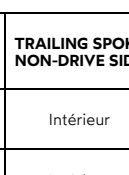
	MODÈLE	MATÉRIAU	TAILLE	TYPE DE JANTE	TYPE DE FREIN	TUBELESS	LARGEUR INTERNE	DÉPORT	TROUS DE RAYON DIRECTIONNELS	TROUS DE RAYON	ERD	ETRTO	RACCORD	LARGEUR DE FOND TUBELESS	VAVLE	PNEUS COMPATIBLES	PRESSION MAXIMALE	PROFIL	
JANTES	JANTE AVANT 29"	MC30-F-29-28H	Aluminium AL6061	29"	Chambre à air sans crochet	Disque	OUI	32 mm	2 mm	OUI	28	604 mm	622 x 32TSS	À manchon	32 mm	44 mm	2,4"-2,8"	**	
	JANTE ARRIÈRE 29"	MC30-R-29-32H	Aluminium AL6061	29"	Chambre à air sans crochet	Disque	OUI	30 mm	-2 mm	OUI	32	600 mm	622 x 30TSS	À manchon	30 mm	44 mm 57 mm on Wild with magnet in valve	2,05"-2,8"	**	
	JANTE ARRIÈRE 27,5"	MC31-R-27-32H	Aluminium AL6061	27,5"	Chambre à air sans crochet	Disque	OUI	30 mm	-2 mm	OUI	32	561,6 mm	584 x 30TSS	À manchon	30 mm	44 mm 57 mm on Wild with magnet in valve	2,05"-2,8"	**	

	No. SPOKES	MODEL	DRIVE SIDE SPOKE PATTERN	NON-DRIVE SIDE SPOKE PATTERN	DRIVE SIDE SPOKE LENGTH	NON-DRIVE SIDE SPOKE LENGTH	DRIVE SIDE ASSEMBLY TENSION	DISC SIDE ASSEMBLY TENSION	LEADING SPOKE DRIVE SIDE	TRAILING SPOKE DRIVE SIDE	LEADING SPOKE NON-DRIVE SIDE	TRAILING SPOKE NON-DRIVE SIDE	
RAYONS	AVANT 29"	28	Sapim E-Light. Butted 14G (2 mm) coudé	3 rayons croisés	3 rayons croisés	298 mm	297 mm	—	1 200 N	Extérieur	Intérieur	Extérieur	Intérieur
	ARRIÈRE 29"	32	Sapim E-Light. Butted 14G (2 mm) coudé	3 rayons croisés	3 rayons croisés	291 mm	292 mm	1 200 N	—	Intérieur	Extérieur	Extérieur	Intérieur
	ARRIÈRE 27,5"	32	Sapim E-Light. Butted 14G (2 mm) coudé	3 rayons croisés	3 rayons croisés	271 mm	271 mm	1 200 N	—	Intérieur	Extérieur	Extérieur	Intérieur

MOYEURS	MODEL	SPACING (OLD)	AXLE	DISC TYPE	SPOKES	FREEHUB BODY	FREEHUB MECHANISM	EMBOUITS	MODEL	MEASUREMENTS	SPOKE NIPPLE WASHERS	POIDS	ROUE	POIDS	USE			
	AVANT 29"	DT SWISS 350 Hybrid Classic IS modèle à partir de l'année-modèle 2024	Boost 110 mm	Thru axle 15mm	6 vis	28 coudé	—		—	AVANT 29"	Sapim Brass Polyax		2 x 14 mm (14G)			Non	AVANT 29"	985 gr +/- 5 %
	ARRIÈRE 29"	DT SWISS 350 Hybrid Classic IS modèle à partir de MY2024	Boost 148 mm	Thru axle 12 mm	6 vis	32 coudé	Sram XD ou Shimano MS		Ratchet 24	ARRIÈRE 29"	Sapim Brass Polyax		2 x 14 mm (14G)			Non	ARRIÈRE 29"	1 160 gr +/- 5 %
	ARRIÈRE 27,5"	DT SWISS 350 Hybrid Classic IS modèle à partir de MY2024	Boost 148 mm	Thru axle 12 mm	6 vis	32 coudé	Sram XD ou Shimano MS		Ratchet 24	ARRIÈRE 27,5"	Sapim Brass Polyax		2 x 14 mm (14G)			Non	ARRIÈRE 27,5"	1 085 gr +/- 5 %

\*\* Pour connaître la pression des pneus maximale, reportez-vous au manuel du propriétaire ou à l'autocollant qui se trouve sur la roue.

[Cliquez sur le modèle de moyeu ou de rayon pour accéder aux informations sur les pièces détachées](#)

**ASTM Condition 5**  
(cf. manuel d'utilisateur)  
Poids maximal du système  
(vélo + cycliste + équipement)  
= **135 kg.**

## MOUNTAIN CONTROL (MC)

## MC32 TEAM POWER (Année-modèle 2025)

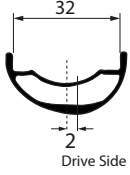
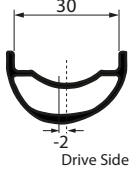
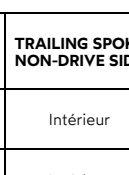
	MODÈLE	MATÉRIAU	TAILLE	TYPE DE JANTE	TYPE DE FREIN	TUBELESS	LARGEUR INTERNE	DÉPORT	TROUS DE RAYON DIRECTIONNELS	TROUS DE RAYON	ERD	ETRTO	RACCORD	LARGEUR DE FOND TUBELESS	VAVLE	PNEUS COMPATIBLES	PRESSION MAXIMALE	PROFIL	
JANTES	JANTE AVANT 29"	MC36-F-29-28 trous	Aluminium AL6061	29"	Chambre à air sans crochet	Disque	OUI	32 mm	2 mm	OUI	28	612,3 mm	622 x 32TSS	À manchon	32 mm	44 mm	2,4"-2,8"	**	
	JANTE ARRIÈRE 29"	MC36-R-29-32 trous	Aluminium AL6061	29"	Chambre à air sans crochet	Disque	OUI	30 mm	-2 mm	OUI	32	610,9 mm	622 x 30TSS	À manchon	30 mm	44 mm 57 mm on Wild with magnet in valve	2,05"-2,8"	**	
	JANTE ARRIÈRE 27,5"	MC37-R-27-32 trous	Aluminium AL6061	27,5"	Chambre à air sans crochet	Disque	OUI	30 mm	-2 mm	OUI	32	572,9 mm	584 x 30TSS	À manchon	30 mm	44 mm 57 mm on Wild with magnet in valve	2,05"-2,8"	**	

	No. SPOKES	MODEL	DRIVE SIDE SPOKE PATTERN	NON-DRIVE SIDE SPOKE PATTERN	DRIVE SIDE SPOKE LENGTH	NON-DRIVE SIDE SPOKE LENGTH	DRIVE SIDE ASSEMBLY TENSION	DISC SIDE ASSEMBLY TENSION	LEADING SPOKE DRIVE SIDE	TRAILING SPOKE DRIVE SIDE	LEADING SPOKE NON-DRIVE SIDE	TRAILING SPOKE NON-DRIVE SIDE	
RAYONS	AVANT 29"	28	Sapim E-Light. Butted 14G (2 mm) coudé	3 rayons croisés	3 rayons croisés	301 mm	300 mm	—	1300 N	Extérieur	Intérieur	Extérieur	Intérieur
	ARRIÈRE 29"	32	Sapim E-Light. Butted 14G (2 mm) coudé	3 rayons croisés	3 rayons croisés	294 mm	295 mm	1300 N	—	Intérieur	Extérieur	Extérieur	Intérieur
	ARRIÈRE 27,5"	32	Sapim E-Light. Butted 14G (2 mm) coudé	3 rayons croisés	3 rayons croisés	275 mm	276 mm	1300 N	—	Intérieur	Extérieur	Extérieur	Intérieur

MOYEUR	MODEL	SPACING (OLD)	AXLE	DISC TYPE	SPOKES	FREEHUB BODY	FREEHUB MECHANISM	EMBOUTS	MODEL	MEASUREMENTS	SPOKE NIPPLE WASHERS	POIDS	ROUE	POIDS	USE		
	AVANT 29"	DT SWISS 350 Hybrid Classic IS modèle à partir de MY2024	Boost 110 mm	Thru axle 15mm	6 vis	28 coudé	—		—	AVANT 29"	Sapim Alloy Double Square		2 x 18 mm (14G)	Non		AVANT 29"	1030 g +/- 5 %
	ARRIÈRE 29"	DT SWISS 350 Hybrid Classic IS modèle à partir de MY2024	Boost 148 mm	Thru axle 12 mm	6 vis	32 coudé	Sram XD ou Shimano MS		10 ° Ratchet 32	ARRIÈRE 29"	Sapim Alloy Double Square		2 x 18 mm (14G)	Non		ARRIÈRE 29"	1180 g +/- 5 %
	ARRIÈRE 27,5"	DT SWISS 350 Hybrid Classic IS modèle à partir de MY2024	Boost 148 mm	Thru axle 12 mm	6 vis	32 coudé	Sram XD ou Shimano MS		10 ° Ratchet 32	ARRIÈRE 27,5"	Sapim Alloy Double Square		2 x 18 mm (14G)	Non		ARRIÈRE 27,5"	1130 g +/- 5 %

\*\* Pour connaître la pression des pneus maximale, reportez-vous au manuel du propriétaire ou à l'autocollant qui se trouve sur la roue.

[Cliquez sur le modèle de moyeu ou de rayon pour accéder aux informations sur les pièces détachées](#)

**ASTM Condition 5**  
(cf. manuel d'utilisateur)  
Poids maximal du système  
(vélo + cycliste + équipement)  
= **135 kg.**

## MOUNTAIN CONTROL (MC)

## MC32 TEAM POWER (à partir de l'année-modèle 2026)

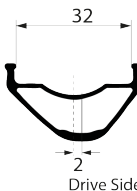
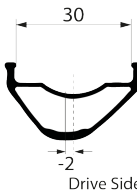
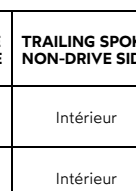
	MODÈLE	MATÉRIAU	TAILLE	TYPE DE JANTE	TYPE DE FREIN	TUBELESS	LARGEUR INTERNE	DÉPORT	TROUS DE RAYON DIRECTIONNELS	TROUS DE RAYON	ERD	ETRTO	RACCORD	LARGEUR DE FOND TUBELESS	VAVLE	PNEUS COMPATIBLES	PRESSION MAXIMALE	PROFIL	
JANTES	JANTE AVANT 29"	MC36-F-29-28 trous	Aluminium AL6061	29"	Chambre à air Minihook	Disque	OUI	32 mm	2 mm	OUI	28	612,3 mm	622 x 32TSS	À manchon	32 mm	44 mm	2,4"-2,8"	**	
	JANTE ARRIÈRE 29"	MC36-R-29-32 trous	Aluminium AL6061	29"	Chambre à air Minihook	Disque	OUI	30 mm	-2 mm	OUI	32	610,9 mm	622 x 30TSS	À manchon	30 mm	44 mm 57 mm on Wild with magnet in valve	2,05"-2,8"	**	
	JANTE ARRIÈRE 27,5"	MC37-R-27-32 trous	Aluminium AL6061	27,5"	Chambre à air Minihook	Disque	OUI	30 mm	-2 mm	OUI	32	572,9 mm	584 x 30TSS	À manchon	30 mm	44 mm 57 mm on Wild with magnet in valve	2,05"-2,8"	**	

	No. SPOKES	MODEL	DRIVE SIDE SPOKE PATTERN	NON-DRIVE SIDE SPOKE PATTERN	DRIVE SIDE SPOKE LENGTH	NON-DRIVE SIDE SPOKE LENGTH	DRIVE SIDE ASSEMBLY TENSION	DISC SIDE ASSEMBLY TENSION	LEADING SPOKE DRIVE SIDE	TRAILING SPOKE DRIVE SIDE	LEADING SPOKE NON-DRIVE SIDE	TRAILING SPOKE NON-DRIVE SIDE	
RAYONS	AVANT 29"	28	Sapim E-Light, Butted 14G (2 mm) coudé	3 rayons croisés	3 rayons croisés	301 mm	300 mm	—	1300 N	Extérieur	Intérieur	Extérieur	Intérieur
	ARRIÈRE 29"	32	Sapim E-Light, Butted 14G (2 mm) coudé	3 rayons croisés	3 rayons croisés	294 mm	295 mm	1300 N	—	Intérieur	Extérieur	Extérieur	Intérieur
	ARRIÈRE 27,5"	32	Sapim E-Light, Butted 14G (2 mm) coudé	3 rayons croisés	3 rayons croisés	275 mm	276 mm	1300 N	—	Intérieur	Extérieur	Extérieur	Intérieur

MOYEUR	MODEL	SPACING (OLD)	AXLE	DISC TYPE	SPOKES	FREEHUB BODY	FREEHUB MECHANISM	EMBOUTS	MODEL	MEASUREMENTS	SPOKE NIPPLE WASHERS	POIDS	ROUE	POIDS	USE		
	AVANT 29"	DT SWISS 350 Hybrid Classic IS modèle à partir de MY2024	Boost 110 mm	Thru axle 15mm	6 vis	28 coudé	—		—	AVANT 29"	Sapim Alloy Double Square		2 x 18 mm (14G)	Non		AVANT 29"	1030 g +/- 5 %
	ARRIÈRE 29"	DT SWISS 350 Hybrid Classic IS modèle à partir de MY2024	Boost 148 mm	Thru axle 12 mm	6 vis	32 coudé	Sram XD ou Shimano MS		10 ° Ratchet 32	ARRIÈRE 29"	Sapim Alloy Double Square		2 x 18 mm (14G)	Non		ARRIÈRE 29"	1180 g +/- 5 %
ARRIÈRE 27,5"	DT SWISS 350 Hybrid Classic IS modèle à partir de MY2024	Boost 148 mm	Thru axle 12 mm	6 vis	32 coudé	Sram XD ou Shimano MS	10 ° Ratchet 32	ARRIÈRE 27,5"	Sapim Alloy Double Square	2 x 18 mm (14G)	Non	ARRIÈRE 27,5"	1130 g +/- 5 %				

\*\* Pour connaître la pression des pneus maximale, reportez-vous au manuel du propriétaire ou à l'autocollant qui se trouve sur la roue.

[Cliquez sur le modèle de moyeu ou de rayon pour accéder aux informations sur les pièces détachées](#)

**ASTM Condition 5**  
(cf. manuel d'utilisateur)  
Poids maximal du système  
(vélo + cycliste + équipement)  
= **135 kg.**

---

## ENTRETIEN DES ROUES OQUO

Les informations reprises dans ce manuel sont destinées avant tout aux revendeurs OQUO et aux utilisateurs qui possèdent un peu d'expérience en entretien de roues.

Si vous êtes un utilisateur qui ne dispose pas des connaissances requises pour exécuter les interventions d'entretien décrites dans ce manuel technique ou pour installer les pièces de rechange mentionnées, rendez-vous chez un revendeur OQUO qui se chargera de la réparation ou de l'entretien.

Vous trouverez les coordonnées du revendeur le plus proche sur notre site Internet :

[www.oquowheels.com](http://www.oquowheels.com)

### ATTENTION

Tout dégât provoqué par une réparation ou un entretien mal exécuté est exclu de la garantie.



Une réparation, un entretien ou une installation de composants incorrects peut avoir un impact sur l'intégrité et le fonctionnement des roues et provoquer un accident entraînant des blessures graves ou mortelles.

### OUTILLAGE

Utilisez toujours les outils et les produits adéquats pour une intervention d'entretien ou une réparation particulière. L'utilisation d'outils mal adaptés ou en mauvais état ou de produits génériques peut endommager les composants et ces dégâts ne sont pas couverts par la garantie.

Reportez-vous aux calendriers d'entretien dans ce manuel pour connaître les vérifications à réaliser et les intervalles d'entretien des roues et de leurs composants.

Consultez la rubrique consacrée à l'entretien des moyeux dans ce manuel pour savoir où obtenir les manuels d'entretien des fabricants.

### TABLEAU DU CALENDRIER D'ENTRETIEN

Reportez-vous au tableau suivant pour connaître les éléments à vérifier et les intervalles d'entretien des roues et de leurs composants.

### ATTENTION

Le calendrier d'entretien des composants indiqué ci-dessous sert de référence et dépend en grande partie de facteurs tels que les conditions météorologiques (des conditions défavorables réduisent considérablement la durée de vie des composants et les intervalles d'entretien), la propreté du vélo et de ses composants (les composants avec de la saleté accumulée s'usent plus rapidement) et l'utilisation (une utilisation plus exigeante du vélo nécessitera des intervalles d'entretien plus courts). Les dommages causés aux composants résultant du non-respect des intervalles d'entretien ne sont pas couverts par les conditions de garantie.

Les outils à utiliser sont spécifiés dans ce manuel. S'agissant des outils à utiliser pour l'entretien des composants d'autres fabricants utilisés sur nos roues, vous trouverez des références vers les manuels d'entretien et les listes respectives d'outils requis.

VÉRIFICATION	FRÉQUENCE		
	Avant chaque sortie	Toutes les 2 à 3 sorties	Tous les 4 à 6 mois (40 à 60 heures)*/**
Nettoyez les roues avec de l'eau savonneuse ou des produits de nettoyage spécifiques pour les vélos. (N'utilisez pas de produits contenant de l'ammoniaque ou des solvants)		✓	✓
Contrôle du serrage et de l'état des axes traversants ou des blocages rapides	✓		
Contrôle de l'état des disques de frein	✓		
Vérification du serrage des disques de frein			✓
Contrôle du centrage de la jante	✓		✓
Contrôle de l'état des pneus (coupures et usure)	✓		
Contrôle manuel de la tension et de l'état des rayons	✓		
Contrôle manuel de la rotation et du jeu des moyeux et des corps de roue libre	✓		
Contrôle de la pression des pneus et des fuites d'air	✓		
Contrôle des dommages au niveau de la jante, des moyeux et des rayons	✓		✓
Contrôle et/ou ajout de produit d'étanchéité pour les pneus tubeless			✓
Nettoyage du produit d'étanchéité liquide dans la jante, le pneu et la valve			✓
Remplacement de la bande de la jante (standard ou tubeless) si nécessaire			✓
Contrôle de la tension des rayons avec un tensiomètre			✓
Entretien des roulements et de la structure selon les instructions du fabricant si nécessaire			✓
Remplacement de la chambre à air pour les pneus standard			✓

\*Ces intervalles peuvent être plus courts selon le style de conduite et les conditions d'utilisation.

\*\*Les utilisateurs plus lourds ou ceux qui utilisent les roues près des limites de poids de leur système peuvent avoir besoin de réduire les intervalles d'entretien.

## OUTILLAGE POUR L'ENTRETIEN ET LE MONTAGE DES ROUES

Voici la liste des outils nécessaires pour réaliser l'entretien correct des roues OQUO au niveau du montage et du centrage. Veuillez consulter la documentation du fabricant des outils requis pour avoir des informations sur l'entretien du moyeu.

Cette liste peut faire l'objet de changement en fonction des caractéristiques des roues, ce qui pourrait nécessiter l'utilisation d'outils qui ne sont pas indiqués ici. En cas de doute, consultez OQUO.

### 1. CENTREUR DE ROUE BILATÉRAL

Utilisez toujours un centreur de roue bilatéral de qualité pour vérifier le centrage et identifier un éventuel voilage des roues. La vérification et l'entretien des roues ne peuvent être réalisés quand les roues sont montées sur le vélo. Les résultats pourraient ne pas être exacts.

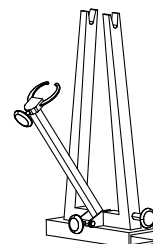

### 2. CLÉ À RAYON

**Externe :** pour régler les embouts de rayon depuis l'extérieur de la jante. Pour la majorité des embouts de rayon.

**Interne :** pour régler les embouts depuis l'intérieur de la jante (fond de jante). Il est possible de régler les embouts de rayon Sapim Double Square aussi bien depuis l'intérieur de la jante que depuis l'extérieur avec une clé à rayon externe.

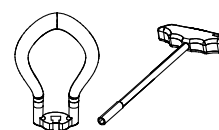

#### ATTENTION

Qu'il s'agisse d'une clé à rayon externe ou interne, elle doit être de la dimension adéquate à l'embout afin d'éviter d'endommager les embouts et/ou de les arrondir. Il est conseillé de disposer de plusieurs clés à rayon de tailles différentes afin de pouvoir trouver celle qui convient le mieux aux embouts de rayon à régler.

### 3. CLÉ À RAYON PLAT

Utilisez cet outil pour tenir les rayons plats lorsque vous serrez l'embout pour éviter de tordre le rayon.

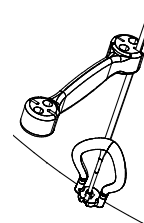

#### 4. TENSIONNÈTRE

Utilisez toujours un tensionnètre de qualitè et vèrifiez règulièrement son ètalonnage conformèment aux instructions du fabricant.

Suivez les instructions du fabricant pour utiliser le tensionnètre correctement et pouvoir interprèter comme il se doit les relevés en fonction des caractèristiques techniques des rayons.

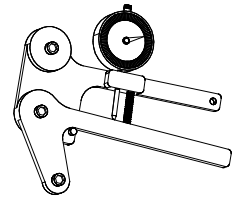

---

#### 5. JUGE D'ALIGNEMENT

Utilisez toujours un comparateur d'alignement de roue afin de vèrifier l'alignement de la jante par rapport aux extrèmités du moyeu en contact avec le côté intèrieur du cadre ou de la fourche.

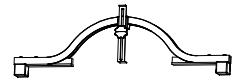

## VÉRIFICATION DE LA TENSION DES RAYONS

Vérifiez régulièrement la tension des rayons et leur état.

Recherchez régulièrement la présence éventuelle d'un voile (1) et d'un saut (2) de la roue et vérifiez également son angle d'inclinaison (3) à l'aide du centreur de roue. Les vérifications et les réglages réalisés sur les roues quand celles-ci sont montées sur le vélo ne sont pas toujours exacts.

Si le réglage d'un rayon s'impose, utilisez une clé à rayon de la bonne taille pour régler la tension de ces rayons.

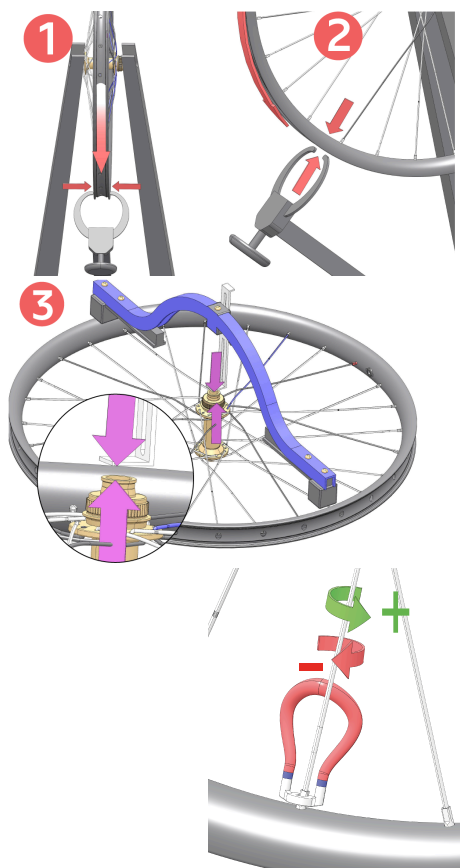

Utilisez une clé pour rayon plat afin de maintenir le rayon pour éviter sa torsion. Il est possible également de tenir des rayons ronds à l'aide d'une pince lisse pour éviter qu'il ne tourne. Évitez d'endommager les rayons.

Après le réglage d'un ou de plusieurs rayons, recherchez à nouveau un éventuel voile ou saut de la roue et revérifiez son alignement. Si vous ajustez la tension de 4 rayons ou plus, détendez la roue et vérifiez son centrage.

Pour savoir comment détendre une roue, consultez la rubrique consacrée au montage de la roue dans ce manuel. Les valeurs de voilage et de tension des roues OQUO sont reprises dans la rubrique consacrée au montage de la roue de ce manuel.

## REPLACEMENT D'UN RAYON

Un rayon cassé, plié ou endommagé doit être remplacé immédiatement.

Pour remplacer un rayon, déposez le pneu et le fond de jante de la roue.

Il faudra peut-être déposer le disque de frein et la cassette (sur la roue arrière) pour remplacer un rayon.

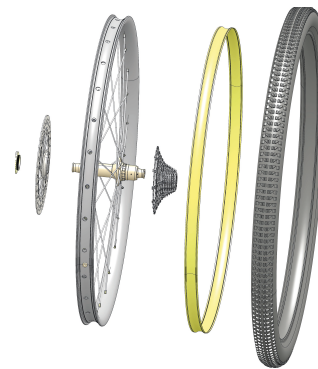

Déposez l'embout (1, 2) à l'aide d'une clé à rayon.

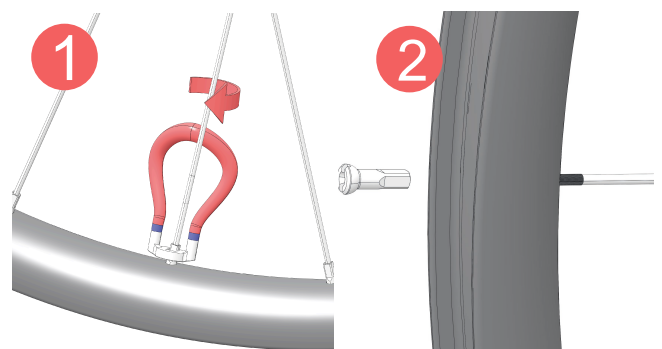

Retirez le rayon du moyeu (3). Si le rayon est cassé, vous pouvez retirer celui-ci avec l'embout et démontez séparément la partie du rayon attachée au moyeu (4).

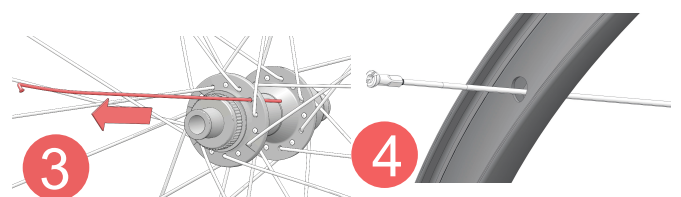

Posez le nouveau rayon depuis le côté du moyeu et dans la position du rayon d'origine.

Consultez la rubrique consacrée au rayonnage du chapitre Construction de la roue de ce manuel pour en savoir plus sur le positionnement des rayons dans les différents croisements. Veuillez consulter le tableau des caractéristiques techniques de ce manuel pour connaître les modèles de rayon et les longueurs compatibles avec vos roues OQUO.

Utilisez un centreur de roue et les outils adéquats pour tendre le nouveau rayon. Une fois la pose terminée, confirmez que la tension du rayon est correcte. Confirmez l'absence de voile et de saut ainsi que l'alignement correct de la roue.

Il faudra peut-être régler plusieurs rayons en plus du rayon remplacé. En cas de pose de plusieurs rayons, détendez la roue conformément aux explications de la rubrique Construction de la roue de ce manuel et confirmez que les valeurs de tolérance d'alignement, de tension et de voile sont correctes.

Reposez le fond de jante, le pneu, le disque de frein et la cassette, dans les cas où la dépose avait été nécessaire.

---

## ENTRETIEN DU MOYEU

### ENTRETIEN DU MOYEU

Consultez le tableau des caractéristiques techniques des roues OQUO dans ce manuel pour identifier le modèle de moyeu adopté par votre roue.

Les informations reprises dans ce manuel ainsi que dans les manuels des autres fabricants cités ici sont destinées avant tout aux revendeurs OQUO ou aux revendeurs des fabricants du composant et aux utilisateurs quelque peu expérimentés dans l'entretien de roues.

Si vous êtes un utilisateur qui ne dispose pas des connaissances requises pour exécuter les interventions d'entretien décrites dans ce manuel technique ou pour installer les pièces de rechange mentionnées, rendez-vous chez un revendeur OQUO qui se chargera de la réparation ou de l'entretien.

Vous trouverez les coordonnées du revendeur le plus proche sur notre site Internet à l'adresse [www.oquowheels.com](http://www.oquowheels.com).

#### ATTENTION

---

Tout dégât provoqué par une réparation ou un entretien mal exécuté est exclu de la garantie.



Une réparation, un entretien ou une installation de composants incorrects peut avoir un impact sur l'intégrité et le fonctionnement des roues et provoquer un accident entraînant des blessures graves ou mortelles.

### MOYEURS INSIDE DT OQUO ET VTT DT SWISS

Consultez la page suivante pour connaître les liens vers les manuels des moyeux DT Swiss VTT sur le site Internet du fabricant :

#### ATTENTION

---

Les moyeux Inside DT Oquo se composent des mêmes composants que les moyeux DT Swiss équivalents (à l'exception du corps du moyeu), les procédures d'entretien et de maintenance sont donc les mêmes que pour les moyeux DT Swiss équivalents.

MODÈLE DE MOYEU	TYPE DE MANUEL/ NOM	TABLE DES MATIÈRES	LIEN VERS LE DOCUMENT
Tous les moyeux DT Swiss et DT Inside Oquo	Manuel d'utilisation/ MANUEL D'UTILISATION DU MOYEU TOUS LES MOYEURS	<ul style="list-style-type: none"> <li>Généralités</li> <li>Avertissements concernant l'utilisation</li> <li>Montage</li> <li>Entretien et soin</li> </ul>	<a href="https://www.dtswiss.com/pmt/00/00/00/00/00/00/10/00/00/00/86/2/MAN_HXWXXXXXX1610S_WEB_ZZ_001.pdf">https://www.dtswiss.com/pmt/00/00/00/00/00/00/10/00/00/00/86/2/MAN_HXWXXXXXX1610S_WEB_ZZ_001.pdf</a>
Moyeux avant DT Swiss et DT Inside Oquo	Manuel technique/ MANUEL TECHNIQUE POUR MOYEURS AVANT	<ul style="list-style-type: none"> <li>Démontage, nettoyage et remplacement des roulements et de l'essieu</li> <li>Outils, composant et matériels requis</li> </ul>	<a href="https://d2a13k6araex7u.cloudfront.net/pmt/00/00/00/00/00/00/10/00/00/05/56/2/MAN_HXD10000005562S_WEB_EN_001.pdf">https://d2a13k6araex7u.cloudfront.net/pmt/00/00/00/00/00/00/10/00/00/05/56/2/MAN_HXD10000005562S_WEB_EN_001.pdf</a>
Moyeu arrière Oquo LTD DT Inside et DT Swiss 240	Manuel technique/ MANUEL TECHNIQUE DU MOYEU RATCHET EXP	<ul style="list-style-type: none"> <li>Démontage, nettoyage et remplacement de toutes les pièces du moyeu</li> <li>Outils, composant et matériels requis</li> </ul>	<a href="https://www.dtswiss.com/pmt/00/00/00/00/00/00/10/00/00/03/11/1/MAN_HXD10000003111S_WEB_EN_001.pdf">https://www.dtswiss.com/pmt/00/00/00/00/00/00/10/00/00/03/11/1/MAN_HXD10000003111S_WEB_EN_001.pdf</a>
	Manuel d'entretien de la carrosserie ENTRETIEN DE LA ROUE LIBRE RATCHET EXP	<ul style="list-style-type: none"> <li>Démontage, nettoyage et remplacement du système Ratchet EXP et de la carrosserie</li> <li>Outils, composant et matériels requis</li> </ul>	<a href="https://www.dtswiss.com/pmt/00/00/00/00/00/00/10/00/00/04/19/3/MAN_HXD10000004193S_XXX_EN_001.pdf">https://www.dtswiss.com/pmt/00/00/00/00/00/00/10/00/00/04/19/3/MAN_HXD10000004193S_XXX_EN_001.pdf</a>
	Manuel de remplacement du Ratchet EXP 36T à EXP 54T CONVERSION DES MOYEURS RATCHET EXP HUBS 36 À 54	<ul style="list-style-type: none"> <li>Remplacement du système Ratchet EXP 36T par le système EXP 54T</li> <li>Outils, composant et matériels requis</li> </ul>	<a href="https://www.dtswiss.com/pmt/00/00/00/00/00/00/10/00/00/03/77/3/MAN_HXD10000003773S_WEB_EN_001.pdf">https://www.dtswiss.com/pmt/00/00/00/00/00/00/10/00/00/03/77/3/MAN_HXD10000003773S_WEB_EN_001.pdf</a>
Moyeu arrière Oquo LTD DT Inside et DT Swiss 350 DEG 72	Page d'aide concernant le moyeu 350 DEG/ DT Swiss	<ul style="list-style-type: none"> <li>Pièces de rechange</li> <li>Manuels</li> <li>Vidéos</li> </ul>	<a href="https://www.dtswiss.com/en/support/product-support?matnr=H350TDDRR32SA5051S">https://www.dtswiss.com/en/support/product-support?matnr=H350TDDRR32SA5051S</a>
	Manuel technique/ MOYEURS RATCHET DEG	<ul style="list-style-type: none"> <li>Démontage, nettoyage et remplacement de toutes les pièces du moyeu</li> <li>Outils, composant et matériels requis</li> </ul>	<a href="https://d2a13k6araex7u.cloudfront.net/pmt/00/00/00/00/00/00/10/00/00/10/00/00/05/10/4/MAN_HXD10000005104S_WEB_EN_001.pdf">https://d2a13k6araex7u.cloudfront.net/pmt/00/00/00/00/00/00/10/00/00/10/00/00/05/10/4/MAN_HXD10000005104S_WEB_EN_001.pdf</a>
	Vidéo/ ENTRETIEN COMPLET 350 DEG	<ul style="list-style-type: none"> <li>Démontage, nettoyage et remplacement de toutes les pièces du moyeu</li> <li>Outils, composant et matériels requis</li> </ul>	<a href="https://www.youtube.com/watch?v=UMLquGPw2Jg">https://www.youtube.com/watch?v=UMLquGPw2Jg</a>
Moyeu arrière Oquo Team DT Inside et DT Swiss 350	Manuel technique/ MANUEL TECHNIQUE DU MOYEU RATCHET	<ul style="list-style-type: none"> <li>Démontage, nettoyage et remplacement de toutes les pièces du moyeu</li> <li>Outils, composant et matériels requis</li> </ul>	<a href="https://www.dtswiss.com/pmt/00/00/00/00/00/00/10/00/00/00/89/6/MAN_WXD10000000896S_WEB_EN_001.pdf">https://www.dtswiss.com/pmt/00/00/00/00/00/00/10/00/00/00/89/6/MAN_WXD10000000896S_WEB_EN_001.pdf</a>
Moyeu arrière DT Swiss 350 Hybrid	Manuel technique/ MANUEL TECHNIQUE DU MOYEU RATCHET	<ul style="list-style-type: none"> <li>Démontage, nettoyage et remplacement de toutes les pièces du moyeu</li> <li>Outils, composant et matériels requis</li> </ul>	<a href="https://www.dtswiss.com/pmt/00/00/00/00/00/00/10/00/00/00/89/6/MAN_WXD10000000896S_WEB_EN_001.pdf">https://www.dtswiss.com/pmt/00/00/00/00/00/00/10/00/00/00/89/6/MAN_WXD10000000896S_WEB_EN_001.pdf</a>
Moyeu arrière DT Swiss 370	Manuel technique MANUEL TECHNIQUE DU MOYEU RATCHET LN	<ul style="list-style-type: none"> <li>Démontage, nettoyage et remplacement de toutes les pièces du moyeu</li> <li>Outils, composant et matériels requis</li> </ul>	<a href="https://www.dtswiss.com/pmt/00/00/00/00/00/00/10/00/00/03/77/4/MAN_HXD10000003774S_WEB_EN_001.pdf">https://www.dtswiss.com/pmt/00/00/00/00/00/00/10/00/00/03/77/4/MAN_HXD10000003774S_WEB_EN_001.pdf</a>

## PIÈCES DE RECHANGE

### PIÈCES DE RECHANGE POUR MOYEUX DT SWISS INSIDE OQUO

Voir le tableau des spécifications techniques des roues OQUO pour connaître le modèle de moyeu de vos roues

#### MOYEUX AVANT DT SWISS INSIDE OQUO

##### Oquo LTD DT Swiss 240 Inside Straight Pull 15x110 24 trous Centerlock

Voir le tableau des spécifications techniques des roues OQUO pour connaître le modèle de moyeu de vos roues

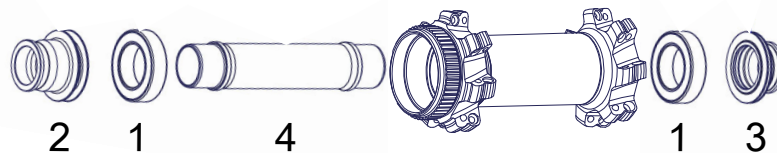

	DESCRIPTION	QTÉ PAR MOYEU	N° D'ARTICLE DT DT SWISS	N° D'ARTICLE ORBEA
1	B.BEARING 1728 ESB/ESNB L	2	HSBXXX00N9115S	<a href="#">XB68</a>
2	FW ADAPT WP XXX/15 L BM DISC	1	HWAXXX00S2760S	<a href="#">XB69</a>
3	FW ADAPT WP XXX/15 R BM DISC	1	HWAXXX00S2761S	<a href="#">XB70</a>
4	FW AXLE AL 110 mm diam 17/64.3 mm	1	HRCXXX00N3296S	<a href="#">XB71</a>

	DESCRIPTION	N° D'ARTICLE DT DT SWISS	N° D'ARTICLE ORBEA
<b>Pâte d'assemblage</b>	Graisse universelle DT Swiss 20 g	HXTXXX00NMG20S	<a href="#">XB72</a>
<b>Outillage</b>	Douille courte de montage Ø17 / 28 mm x 40 mm	HXTXXX00N9345S	<a href="#">XB73</a>
	Outil d'axe Ø17 mm	HXTXXX00N5067S	<a href="#">XB74</a>

Cliquez sur la référence pour acheter la pièce en ligne. Les pièces de rechange pour les moyeux sont disponibles exclusivement chez les revendeurs Orbea via Kide (accès B2B)

**MOYEUX AVANT DT SWISS INSIDE OQUO****Oquo TEAM DT Swiss 350 Inside Straight Pull 15x10 28 trous Centerlock/6 vis**

Voir le tableau des spécifications techniques des roues OQUO pour connaître le modèle de moyeu de vos roues

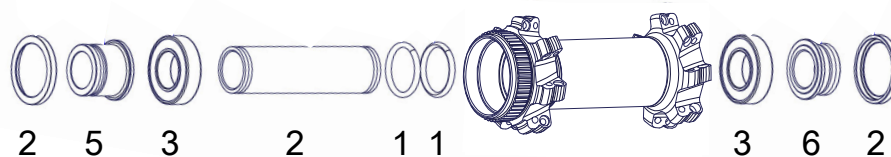

	DESCRIPTION	QTÉ PAR MOYEU	N° D'ARTICLE DT SWISS	N° D'ARTICLE ORBEA
1	O-RING diam 18X2.5mm NBR 70 SHORE ISO3601	2	HSOXXX00X2164S	XC04
2	FW COVER FOR TA15 mm	2	HCD00100S4603S	XC05
3	B.BEARING 6902 ESB/ESNB L	2	HSBXXX00N2336S	XC06
4	SPACER diam 15mm x 67.2mm	1	HXD00000N6567C	XC07
5	FW ADAPT SP XXX/15 L B	1	HCA00100S7745S	XC08
6	FW ADAPT SP XXX/15 R B	1	HCA00100S7744S	XC09

	DESCRIPTION	N° D'ARTICLE DT SWISS	N° D'ARTICLE ORBEA
<b>Pâte d'assemblage</b>	Graisse universelle DT Swiss 20 g	HXTXXX00NMG20S	XB72
<b>Outillage</b>	Jeu d'outil 350 15 mm	HWTXXX00N5290S	XC10
	Outil de montage	HXTXXX00N9793S	XC11

Cliquez sur la référence pour acheter la pièce en ligne. Les pièces de rechange pour les moyeux sont disponibles exclusivement chez les revendeurs Orbea via Kide (accès B2B)

## MOYEUX AVANT DT SWISS INSIDE OQUO

### Oquo LTD DT Swiss 350 Inside coudé 15x110 28 trous 6 vis

Voir le tableau des spécifications techniques des roues OQUO pour connaître le modèle de moyeu de vos roues

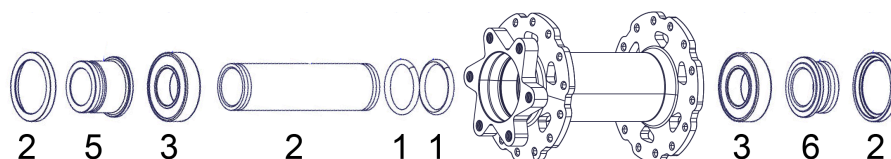

	DESCRIPTION	QTÉ PAR MOYEU	N° D'ARTICLE DT SWISS	N° D'ARTICLE ORBEA
1	O-RING diam 18X2.5mm NBR 70 SHORE ISO3601	2	HSOXXX00X2164S	XC04
2	FW COVER FOR TA15 mm	2	HCD00100S4603S	XC05
3	B.BEARING 6902 ESB/ESNB L	2	HSBXXX00N2336S	XC06
4	SPACER diam 15mm x 67.2mm	1	HXD00000N6567C	XC07
5	FW ADAPT SP XXX/15 L B	1	HCA00100S7745S	XC08
6	FW ADAPT SP XXX/15 R B	1	HCA00100S7744S	XC09

	DESCRIPTION	N° D'ARTICLE DT SWISS	N° D'ARTICLE ORBEA
<b>Pâte d'assemblage</b>	Graisse universelle DT Swiss 20 g	HXTXXX00NMG20S	XB72
<b>Outillage</b>	Jeu d'outil 350 15 mm	HWTXXX00N5290S	XC10
	Outil de montage	HXTXXX00N9793S	XC11

Cliquez sur la référence pour acheter la pièce en ligne. Les pièces de rechange pour les moyeux sont disponibles exclusivement chez les revendeurs Orbea via Kide (accès B2B)

## MOYEURS ARRIÈRE DT SWISS INSIDE OQUO

### Oquo LTD DT Swiss 240 Inside Straight Pull 12x148 28 trous Centerlock

Voir le tableau des spécifications techniques des roues OQUO pour connaître le modèle de moyeu de vos roues

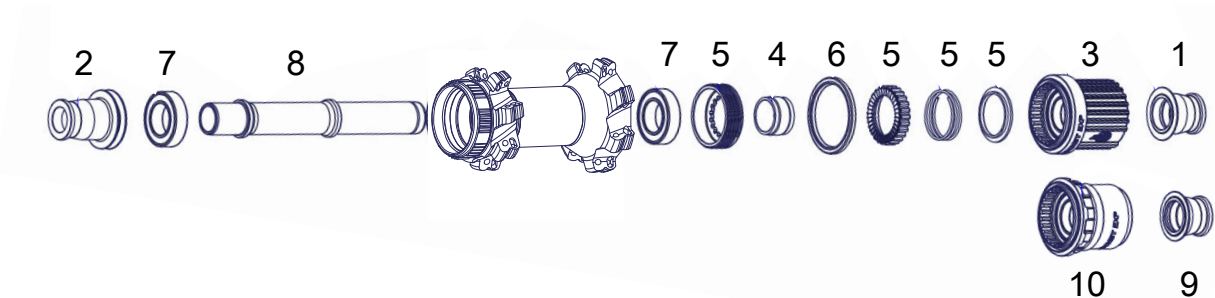

	DESCRIPTION	QTÉ PAR MOYEU	N° D'ARTICLE DT SWISS	N° D'ARTICLE ORBEA
1	RW ADAPT WP XXX/12 R BM MS	1	HWAXXX00S2766S	<a href="#">XB87</a>
2	RW ADAPT WP XXX/12 L BM	1	HWAXXX00S2763S	<a href="#">XB88</a>
3	FB W MTB SHI MS EXP AL LI SL M	1	HWRABL00S4863S	<a href="#">XB89</a>
4	SPACER ALLOY 10.7 EXP	1	HRDXXX00N8242S	<a href="#">XB90</a>
5	SERVICE KIT RATCHET 36T EXP W/O TOOL	1	HWYXXX00N0042S	<a href="#">XB91</a>
6	SEAL HUB/ROTOR (diam 30x36x2.5 mm)	1	HSOXXX00N1031S	<a href="#">XB92</a>
7	B.BEARING 1526 ESB/ESNB L	2	HSBXXX00N3741S	<a href="#">XB93</a>
8	RW AXLE AL XXX mm diam 15/52.85 mm EXP	1	HCCXXX00S3303S	<a href="#">XB94</a>
9	RW ADAPT WP XXX/12 R BM SRAM XD	1	HWAXXX00S2767S	<a href="#">XB95</a>
10	FB W MTB SRA XD EXP AL ST SL M	1	HWRABL00S3830S	<a href="#">XB96</a>

	DESCRIPTION	N° D'ARTICLE DT SWISS	N° D'ARTICLE ORBEA
<b>Pâte d'assemblage</b>	Graisse universelle DT Swiss 20 g	HXTXXX00NMG20S	<a href="#">XB72</a>
	Graisse spéciale DT Swiss 20 g	HXT10032508S	<a href="#">XB97</a>
<b>Outillage</b>	Douille courte de montage 15 x 26 x 40 mm	HWTXXX00N5290S	<a href="#">XB98</a>
	Outil de montage/démontage pour ratchet fileté	HXTXXX00N9793S	<a href="#">XB99</a>
	Outil de montage/démontage roulement à bille côté transmission	HWTXXX00N5290S	<a href="#">XC01</a>
	Outil d'installation pour joint de moyeu	HXTXXX00N9793S	<a href="#">XC02</a>

Cliquez sur la référence pour acheter la pièce en ligne. Les pièces de rechange pour les moyeux sont disponibles exclusivement chez les revendeurs Orbea via Kide (accès B2B)

## MOYEUX ARRIÈRE DT SWISS INSIDE OQUO

### Oquo LTD DT Swiss 350 Inside Straight Pull 12x148 28/32 trous Centerlock/6 vis

Voir le tableau des spécifications techniques des roues OQUO pour connaître le modèle de moyeu de vos roues

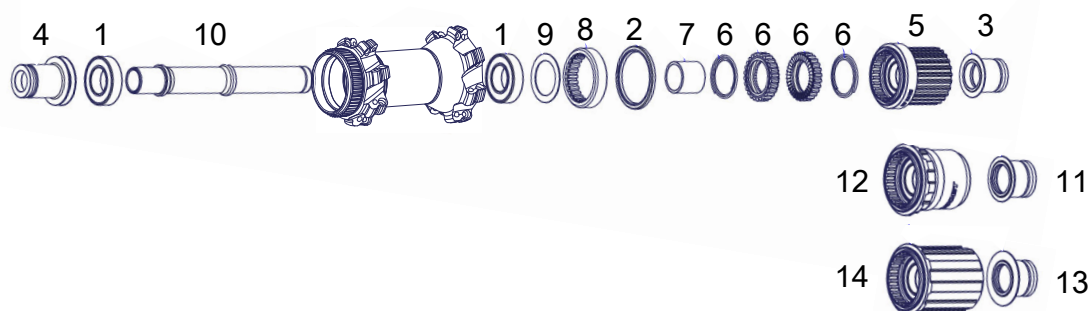

	DESCRIPTION	QTÉ PAR MOYEU	N° D'ARTICLE DT SWISS	N° D'ARTICLE ORBEA
1	B.BEARING 6902 ESB/ESNB L	2	HSBXXX00N2336S	XC06
2	SEAL HUB/ROTOR (diam 30x36x2.5mm)	1	HSOXXX00N1031S	XB92
3	RW ADAPT WP XXX/12 R B MS	1	HWA00100S7912S	XC15
4	RW ADAPT WP XXX/12 L B	1	HWA00100S7841S	XC17
5	FB W MTB SHI MS RAT AL LI SL B	1	HWRABL00S2148S	XC19
6	SERVICE KIT RATCHET 36T	1	HWTXXX00NSK36S	XC20
7	SPACER ALLOY 15.4 mm BL	1	HCDXXX00S1077S	XC21
8	RING NUT STEEL M34X1 240	1	HXDXXX00N1131S	XC22
9	SHIM RING diam 28/20X0.5mm	1	HCDXXX00S1083S	XC23
10	RW AXLE AL 148mm diam 15/48.2mm	1	HCCXXX00S6450S	XC24
11	RW ADAPT WP XXX/12 R B SRAM XD	1	HWA00100S7513S	XC25
12	FB W MTB SRA XD RAT AL ST SL B	1	HWRAAL00S3114S	XC26
13	RW ADAPT WP XXX/12 R B	1	HWA00100S7892S	XC27
14	FB W MTB SHI RAT AL LI	1	HWRABL00S1239S	XC28

	DESCRIPTION	N° D'ARTICLE DT SWISS	N° D'ARTICLE ORBEA
Pâte d'assemblage	Graisse universelle DT Swiss 20 g	HXTXXX00NMG20S	XB72
	Graisse spéciale DT Swiss 20 g	HXT10032508S	XB97
Outillage	Douille courte de montage 15 x 26 x 40 mm	HWTXXX00N5290S	XB98
	Outil d'installation pour joint de moyeu	HXTXXX00N1000S	XC02
	Outil pour bague de cliquet fileté	HXTXXX00N5027S	XC32

Cliquez sur la référence pour acheter la pièce en ligne. Les pièces de rechange pour les moyeux sont disponibles exclusivement chez les revendeurs Orbea via Kide (accès B2B)

## MOYEUX ARRIÈRE DT SWISS INSIDE OQUO

## Oquo LTD DT Swiss Inside 350 DEG coudé 12x148 32 trous 6 vis

Voir le tableau des spécifications techniques des roues OQUO pour connaître le modèle de moyeu de vos roues

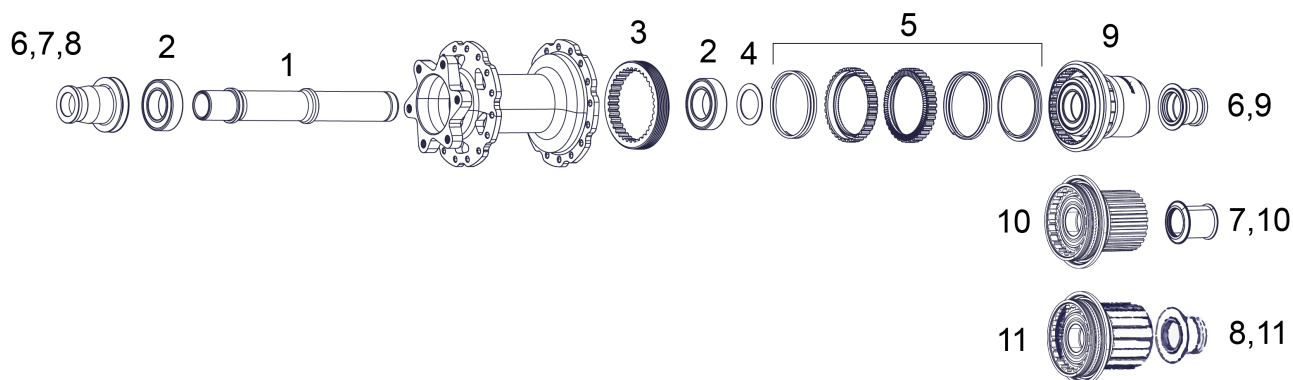

	DESCRIPTION	QTÉ PAR MOYEU	N° D'ARTICLE DT SWISS	N° D'ARTICLE ORBEA
1	RW AXLE AL 148mm diam 15/48.2mm	1	HCCXXX00S6450S	<a href="#">XC24</a>
2	B.BEARING 6902 ESB/ESNB L	2	HSBXXX00N2336S	<a href="#">XC06</a>
3	RING NUT ST M45X2-2MM DEG	1	HXDXXX00N9037S	<a href="#">XJ88</a>
4	SPACER ALLOY 2.95mm N	1	HCD14200N9313S	<a href="#">XJ89</a>
5	SERVICE KIT RATCHET 72T DEG	1	HWYXXX00N6599S	<a href="#">XJ90</a>
6	RW ADAPT KIT 142/Ø12 240 SRAM XD (ONLY CAPS)	1	HWGXXX00S3188S	<a href="#">X649</a>
7	RW ADAPT KIT XXX/12 B MS (ONLY CAPS)	1	HWGXXX00S5643S	<a href="#">X647</a>
8	CONVERSION KIT X12 HG (ONLY CAPS)	1	HWGXXX0002193C	<a href="#">X648</a>
9	FB K MTB SRA XD DEG 12/148 AL ST SL B	1	HWYABL00S2779S	<a href="#">XJ91</a>
10	FB K MTB SHI MS DEG 12/148 AL ST SL B	1	HWYABL00S2787S	<a href="#">XJ92</a>
11	FB K MTB SHI DEG 12/148 AL ST SL B	1	HWYABL00S2786S	<a href="#">XJ93</a>

	DESCRIPTION	N° D'ARTICLE DT SWISS	N° D'ARTICLE ORBEA
<b>Pâte d'assemblage</b>	Graisse universelle DT Swiss 20 g	HXTXXX00NMG20S	<a href="#">XB72</a>
	Graisse spéciale DT Swiss 20 g	HXT10032508S	<a href="#">XB97</a>
<b>Outils</b>	Douille courte de montage 15 x 26 x 40 mm	HWTXXX00N5290S	<a href="#">XB98</a>
	Douille courte de montage Ø15 / 28 x 35 mm	HXTXXX00N5024S	<a href="#">XC02</a>
	Outil pour écrou à anneau DEG	HXTXXX00N2612S	<a href="#">XJ94</a>

Cliquez sur la référence pour acheter la pièce en ligne. Les pièces de rechange pour les moyeux sont disponibles exclusivement chez les revendeurs Orbea via Kide (accès B2B)

## PIÈCES DE RECHANGE POUR LES MOYEUX DT SWISS

Voir le tableau des spécifications techniques des roues OQUO pour connaître le modèle de moyeu de vos roues

### MOYEUX AVANT DT SWISS

#### DT Swiss 240 coudé 15X110 24/28 trous Centerlock/6 vis

Voir le tableau des spécifications techniques des roues OQUO pour connaître le modèle de moyeu de vos roues

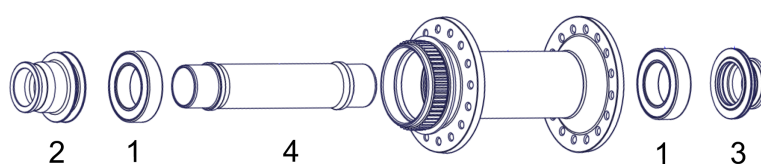

	DESCRIPTION	QTÉ PAR MOYEU	N° D'ARTICLE DT DT SWISS	N° D'ARTICLE ORBEA
1	B.BEARING 1728 ESB/ESNB L	2	HSBXXX00N9115S	<a href="#">XB68</a>
2	FW ADAPT WP XXX/15 L BM DISC	1	HWAXXX00S2760S	<a href="#">XB69</a>
3	FW ADAPT WP XXX/15 R BM DISC	1	HWAXXX00S2761S	<a href="#">XB70</a>
4	FW AXLE AL 110 mm diam 17/64.3 mm	1	HRCXXX00N3296S	<a href="#">XB71</a>

	DESCRIPTION	N° D'ARTICLE DT SWISS	N° D'ARTICLE ORBEA
<b>Pâte d'assemblage</b>	Graisse universelle DT Swiss 20 g	HXTXXX00NMG20S	<a href="#">XB72</a>
<b>Outils</b>	Douille courte de montage Ø17 / 28 mm x 40 mm	HXTXXX00N9345S	<a href="#">XB73</a>
	Outil d'axe Ø17 mm	HXTXXX00N5067S	<a href="#">XB74</a>

Cliquez sur la référence pour acheter la pièce en ligne. Les pièces de rechange pour les moyeux sont disponibles exclusivement chez les revendeurs Orbea via Kide (accès B2B)

## MOYEUX AVANT DT SWISS

## DT Swiss 350 coudé 15x110 28 trous Centerlock/6 vis

Voir le tableau des spécifications techniques des roues OQUO pour connaître le modèle de moyeu de vos roues

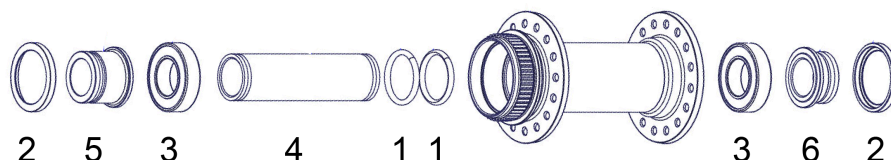

	DESCRIPTION	QTÉ PAR MOYEU	N° D'ARTICLE DT SWISS	N° D'ARTICLE ORBEA
1	O-RING diam 18X2.5mm NBR 70 SHORE ISO3601	2	HSOXXX00X2164S	XC04
2	FW COVER FOR TA15 mm	2	HCD00100S4603S	XC05
3	B.BEARING 6902 ESB/ESNB L	2	HSBXXX00N2336S	XC06
4	SPACER diam 15mm x 67.2mm	1	HXD00000N6567C	XC07
5	FW ADAPT SP XXX/15 L B	1	HCA00100S7745S	XC08
6	FW ADAPT SP XXX/15 R B	1	HCA00100S7744S	XC09

	DESCRIPTION	N° D'ARTICLE DT SWISS	N° D'ARTICLE ORBEA
<b>Pâte d'assemblage</b>	Graisse universelle DT Swiss 20 g	HXTXXX00NMG20S	XB72
<b>Outillage</b>	Jeu d'outil 350 15 mm	HWTXXX00N5290S	XC10
	Outil de montage	HXTXXX00N9793S	XC11

Cliquez sur la référence pour acheter la pièce en ligne. Les pièces de rechange pour les moyeux sont disponibles exclusivement chez les revendeurs Orbea via Kide (accès B2B)

## MOYEUX AVANT DT SWISS

## DT Swiss 350 coudé 20x110 28 trous 6 vis

Voir le tableau des spécifications techniques des roues OQUO pour connaître le modèle de moyeu de vos roues

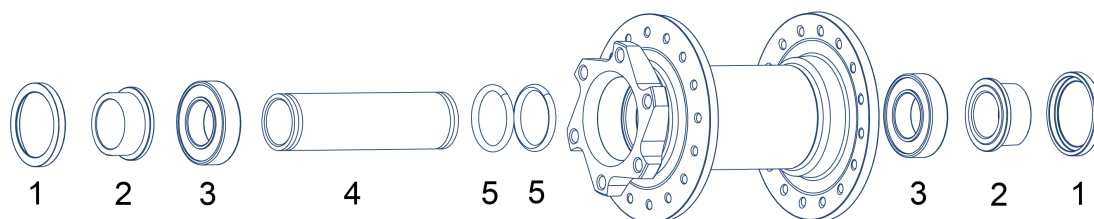

	DESCRIPTION	QTÉ PAR MOYEU	N° D'ARTICLE DT SWISS	N° D'ARTICLE ORBEA
1	FW COVER FOR TA20mm	2	HCDXXX00S1461S	XJ95
2	FW ADAPT SP 110X DBIS TA20 B	2	HCAXXX00S6824S	XJ96
3	B.BEARING 6904 ESB/ESNB L	2	HSBXXX00N1414S	XJ97
4	FW SPACER 65.1x25MM	1	HDXXXX00N6823S	XJ98
5	O-RING diam 18X2.5mm NBR 70 SHORE ISO3601	2	HSOXXX00X2164S	XC04

	DESCRIPTION	N° D'ARTICLE DT SWISS	N° D'ARTICLE ORBEA
<b>Pâte d'assemblage</b>	Graisse universelle DT Swiss 20 g	HXTXXX00NMG20S	XB72
<b>Outillage</b>	Jeu d'outil 350 20 mm	HWTXXX00N5292S	—
	Outil de montage	HXTXXX00N9793S	XC11

Cliquez sur la référence pour acheter la pièce en ligne. Les pièces de rechange pour les moyeux sont disponibles exclusivement chez les revendeurs Orbea via Kide (accès B2B)

## MOYEUX AVANT DT SWISS

## DT Swiss 370 coudé 15x110 28 trous 6 vis

Voir le tableau des spécifications techniques des roues OQUO pour connaître le modèle de moyeu de vos roues

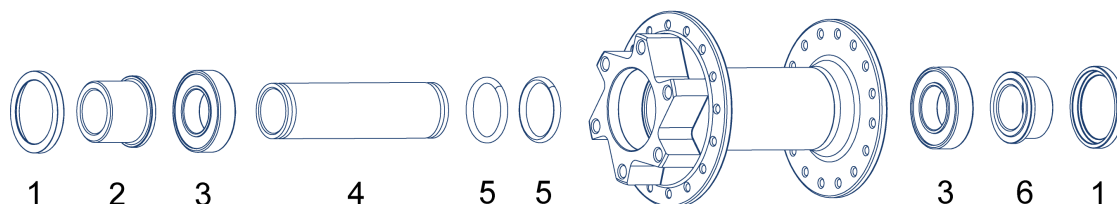

	DESCRIPTION	QTÉ PAR MOYEU	N° D'ARTICLE DT SWISS	N° D'ARTICLE ORBEA
1	FW COVER FOR TA15MM	2	HCD00100S4603S	XC05
2	FW ADAPT SP 100L DBCL SA15 S	1	HCA00100S4601S	XC48
3	B.BEARING 6902 ESB/ESNB L	2	HSBXXX00N2336S	XC06
4	SPACER Ø15MM x 67.2MM	1	HXD00000N6567C	XC07
5	O-RING Ø18X2.5MM NBR 70 SHORE ISO3601	2	HSOXXX00X2164S	XC04
6	FW ADAPT SP 100R DBCL SA15 S	1	HCA00100S4602S	XC47

	DESCRIPTION	N° D'ARTICLE DT SWISS	N° D'ARTICLE ORBEA
<b>Pâte d'assemblage</b>	Graisse universelle DT Swiss 20 g	HXTXXX00NMG20S	XB72
<b>Outillage</b>	Jeu d'outil 350 15 mm	HWTXXX00N5290S	XC10
	Outil de montage	HXTXXX00N9793S	XC11

Cliquez sur la référence pour acheter la pièce en ligne. Les pièces de rechange pour les moyeux sont disponibles exclusivement chez les revendeurs Orbea via Kide (accès B2B)

## MOYEURS AVANT DT SWISS

## DT Swiss 350 Hybrid coudé 15x110 32 trous (jusqu'à l'année-modèle 2023) 6 vis

Voir le tableau des spécifications techniques des roues OQUO pour connaître le modèle de moyeu de vos roues

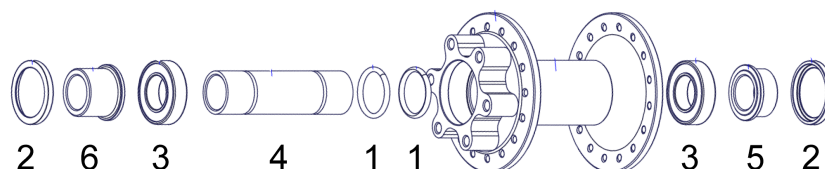

	DESCRIPTION	QTÉ PAR MOYEU	N° D'ARTICLE DT SWISS	N° D'ARTICLE ORBEA
1	O-RING diam 18X2.5mm NBR 70 SHORE ISO3601	2	HSOXXX00X2164S	XC04
2	FW COVER FOR TA15 mm	2	HCD00100S4603S	XC05
3	B.BEARING 6902 ESB/ESNB L	2	HSBXXX00N2336S	XC06
4	SPACER diam 15mm x 67.2M	1	HXD00000N6449S	XC46
5	FW ADAPT SP 100R DBCL SA15 S	1	HCA00100S4602S	XC47
6	FW ADAPT SP 100L DBCL SA15 S	1	HCA00100S4601S	XC48

	DESCRIPTION	N° D'ARTICLE DT SWISS	N° D'ARTICLE ORBEA
<b>Pâte d'assemblage</b>	Graisse universelle DT Swiss 20 g	HXTXXX00NMG20S	XB72
<b>Outillage</b>	Jeu d'outil 350 15 mm	HWTXXX00N5290S	XC10
	Outil de montage	HXTXXX00N9793S	XC11

Cliquez sur la référence pour acheter la pièce en ligne. Les pièces de rechange pour les moyeux sont disponibles exclusivement chez les revendeurs Orbea via Kide (accès B2B)

## MOYEUX AVANT DT SWISS

## DT Swiss 350 Hybrid coudé 15x110 28 trous (à partir de l'année-modèle 2024) 6 vis

Voir le tableau des spécifications techniques des roues OQUO pour connaître le modèle de moyeu de vos roues

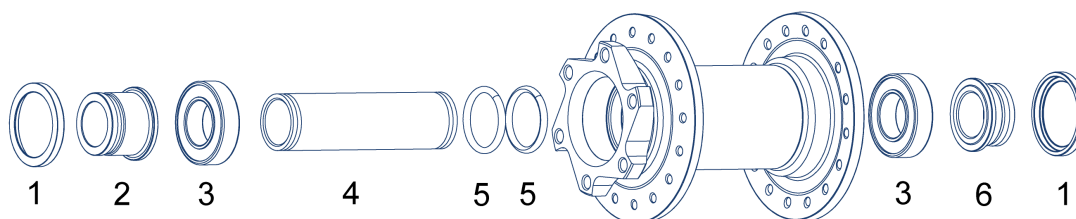

	DESCRIPTION	QTÉ PAR MOYEU	N° D'ARTICLE DT SWISS	N° D'ARTICLE ORBEA
1	FW COVER FOR TA15 mm	2	HCD00100S4603S	XC05
2	FW ADAPT SP XXX/15 L B	1	HCA00100S7745S	XC08
3	B.BEARING 6902 ESB/ESNB L	2	HSBXXX00N2336S	XC06
4	SPACER Ø15MM x 67.2MM	1	HXD00000N6567C	XC07
5	O-RING diam 18X2.5mm NBR 70 SHORE ISO3601	2	HSOXXX00X2164S	XC04
6	FW ADAPT SP XXX/15 R B	1	HCA00100S7744S	XC09

	DESCRIPTION	N° D'ARTICLE DT SWISS	N° D'ARTICLE ORBEA
<b>Pâte d'assemblage</b>	Graisse universelle DT Swiss 20 g	HXTXXX00NMG20S	XB72
<b>Outillage</b>	Jeu d'outil 350 15 mm	HWTXXX00N5290S	XC10
	Outil de montage	HXTXXX00N9793S	XC11

Cliquez sur la référence pour acheter la pièce en ligne. Les pièces de rechange pour les moyeux sont disponibles exclusivement chez les revendeurs Orbea via Kide (accès B2B)

## MOYEUX ARRIÈRE DT SWISS

## DT Swiss 240 coudé 12x148 28 trous Centerlock

Voir le tableau des spécifications techniques des roues OQUO pour connaître le modèle de moyeu de vos roues

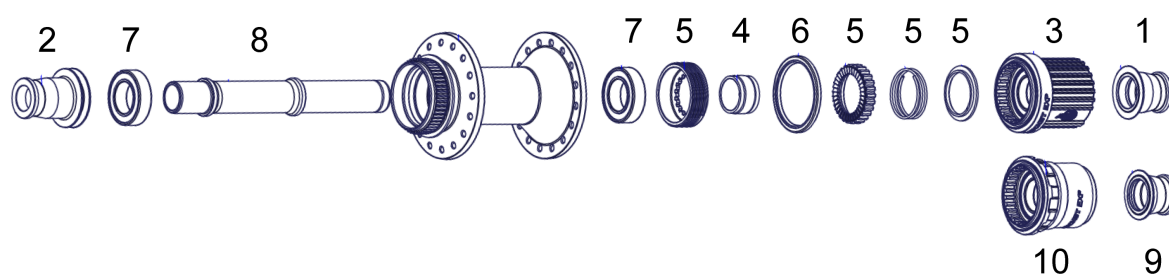

	DESCRIPTION	QTÉ PAR MOYEU	N° D'ARTICLE DT SWISS	N° D'ARTICLE ORBEA
1	RW ADAPT WP XXX/12 R BM MS	1	HWAXXX00S2766S	<a href="#">XB87</a>
2	RW ADAPT WP XXX/12 L BM	1	HWAXXX00S2763S	<a href="#">XB88</a>
3	FB W MTB SHI MS EXP AL LI SL M	1	HWRABL00S4863S	<a href="#">XB89</a>
4	SPACER ALLOY 10.7 EXP	1	HRDXXX00N8242S	<a href="#">XB90</a>
5	SERVICE KIT RATCHET 36T EXP W/O TOOL	1	HWYXXX00N0042S	<a href="#">XB91</a>
6	SEAL HUB/ROTOR (diam 30x36x2.5 mm)	1	HSOXXX00N1031S	<a href="#">XB92</a>
7	B.BEARING 1526 ESB/ESNB L	2	HSBXXX00N3741S	<a href="#">XB93</a>
8	RW AXLE AL XXX mm diam 15/52.85 mm EXP	1	HCCXXX00S3303S	<a href="#">XB94</a>
9	RW ADAPT WP XXX/12 R BM SRAM XD	1	HWAXXX00S2767S	<a href="#">XB95</a>
10	FB W MTB SRA XD EXP AL ST SL M	1	HWRABL00S3830S	<a href="#">XB96</a>

	DESCRIPTION	N° D'ARTICLE DT SWISS	N° D'ARTICLE ORBEA
<b>Pâte d'assemblage</b>	Graisse universelle DT Swiss 20 g	HXTXXX00NMG20S	<a href="#">XB72</a>
	Graisse spéciale DT Swiss 20 g	HXT10032508S	<a href="#">XB97</a>
<b>Outils</b>	Douille courte de montage 15 x 26 x 40 mm	HWTXXX00N5290S	<a href="#">XB98</a>
	Outil de montage/démontage pour ratchet fileté	HXTXXX00N9793S	<a href="#">XB99</a>
	Outil de montage/démontage roulement à bille côté transmission	HWTXXX00N5290S	<a href="#">XC01</a>
	Outil d'installation pour joint de moyeu	HXTXXX00N9793S	<a href="#">XC02</a>

Cliquez sur la référence pour acheter la pièce en ligne. Les pièces de rechange pour les moyeux sont disponibles exclusivement chez les revendeurs Orbea via Kide (accès B2B)

## MOYEUX ARRIÈRE DT SWISS

## DT Swiss 350 coudé 12x148 28/32 trous Centerlock/6 vis

Voir le tableau des spécifications techniques des roues OQUO pour connaître le modèle de moyeu de vos roues

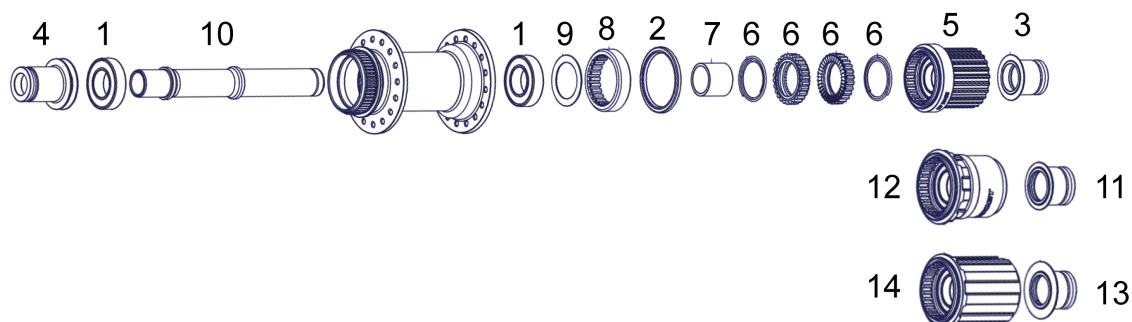

	DESCRIPTION	QTÉ PAR MOYEU	N° D'ARTICLE DT SWISS	N° D'ARTICLE ORBEA
1	B.BEARING 6902 ESB/ESNB L	2	HSBXXX00N2336S	XC06
2	SEAL HUB/ROTOR (diam 30x36x2.5mm)	1	HSOXXX00N1031S	XB92
3	RW ADAPT WP XXX/12 R B MS	1	HWA00100S7912S	XC15
4	RW ADAPT WP XXX/12 L B	1	HWA00100S7841S	XC17
5	FB W MTB SHI MS RAT AL LI SL B	1	HWRABL00S2148S	XC19
6	SERVICE KIT RATCHET 36T SL	1	HWTXXX00NSK36S	XC20
7	SPACER ALLOY 15.4 mm BL	1	HCDXXX00S1077S	XC21
8	RING NUT STEEL M34X1 240	1	HXDXXX00N1131S	XC22
9	SHIM RING diam 28/20X0.5mm	1	HCDXXX00S1083S	XC23
10	RW AXLE AL 148mm diam 15/48.2mm	1	HCCXXX00S6450S	XC24
11	RW ADAPT WP XXX/12 R B SRAM XD	1	HWA00100S7513S	XC25
12	FB W MTB SRA XD RAT AL ST SL B	1	HWRACL00S3114S	XC26
13	RW ADAPT WP XXX/12 R B	1	HWA00100S7892S	XC27
14	FB W MTB SHI RAT AL LI SL B	1	HWRABL00S1239S	XC28

	DESCRIPTION	N° D'ARTICLE DT SWISS	N° D'ARTICLE ORBEA
Pâte d'assemblage	Graisse universelle DT Swiss 20 g	HXTXXX00NMG20S	XB72
	Graisse spéciale DT Swiss 20 g	HXT10032508S	XB97
Outillage	Douille courte de montage 15 x 26 x 40 mm	HWTXXX00N5290S	XB98
	Outil d'installation pour joint de moyeu	HXTXXX00N1000S	XC02
	Outil pour bague de cliquet fileté	HXTXXX00N5027S	XC32

Cliquez sur la référence pour acheter la pièce en ligne. Les pièces de rechange pour les moyeux sont disponibles exclusivement chez les revendeurs Orbea via Kide (accès B2B)



## MOYEUX ARRIÈRE DT SWISS

## DT Swiss 350 Hybrid coudé 12x148 32 trous (jusqu'à l'année-modèle 2023) 6 vis

Voir le tableau des spécifications techniques des roues OQUO pour connaître le modèle de moyeu de vos roues

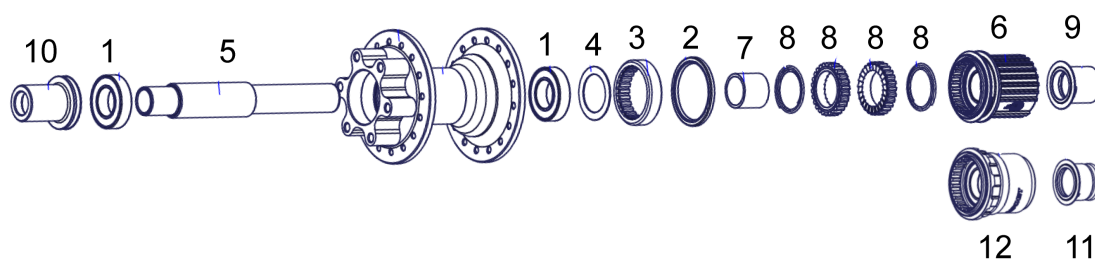

	DESCRIPTION	QTÉ PAR MOYEU	N° D'ARTICLE DT SWISS	N° D'ARTICLE ORBEA
1	B.BEARING 6902 ESB/ESNB L	2	HSBXXX00N2336S	XC06
2	SEAL HUB/ROTOR (diam 30x36x2.5 mm)	1	HSOXXX00N1031S	XB92
3	RING NUT STEEL M34X1 240	1	HDXXXX00N1131S	XC22
4	SHIM RING diam 28/20X0.5 mm	1	HCDXXX00S1083S	XC23
5	RW AXLE AL 148 mm diam 15/48.2 mm	1	HCCXXX00S6450S	XC24
6	FB W MHY SHI MS RAT ST ST SL B	1	HWRABL00S0758S	XC34
7	SPACER ALLOY 15.4 (ROTOR S)	1	HRDXXX00N4636S	XC35
8	SERVICE KIT RATCHET 24T	1	HWTXXX00NSKTFS	XC36
9	RW ADAPT WP XXXR TA12 B MS	1	HWAXXX00S0491S	XC37
10	RW ADAPT WP 142L DBIS SA12 S	1	HWA00100S2193C	XC38
11	RW ADAPT WP XXXR TA12 B SRAM XD	1	HWAXXX00S3188S	XC39
12	FB W MHY SRA XD RAT ST ST SL B	1	HWRAXL00S3224S	XC40

	DESCRIPTION	N° D'ARTICLE DT SWISS	N° D'ARTICLE ORBEA
Pâte d'assemblage	Graisse universelle DT Swiss 20 g	HXTXXX00NMG20S	XB72
	Graisse spéciale DT Swiss 20 g	HXT10032508S	XB97
Outillage	Outil d'installation pour joint de moyeu	HXTXXX00N1000S	XC02
	Outil pour bague de cliquet fileté	HXTXXX00N5027S	XC32
	Douille courte de montage Ø15 / 28 x 35 mm	HXTXXX00N5024S	XC41

Cliquez sur la référence pour acheter la pièce en ligne. Les pièces de rechange pour les moyeux sont disponibles exclusivement chez les revendeurs Orbea via Kide (accès B2B)

## MOYEURX ARRIÈRE DT SWISS

## DT Swiss 350 Hybrid coudé 12x148 32 trous (à partir de l'année-modèle 2024) 6 vis

Voir le tableau des spécifications techniques des roues OQUO pour connaître le modèle de moyeu de vos roues

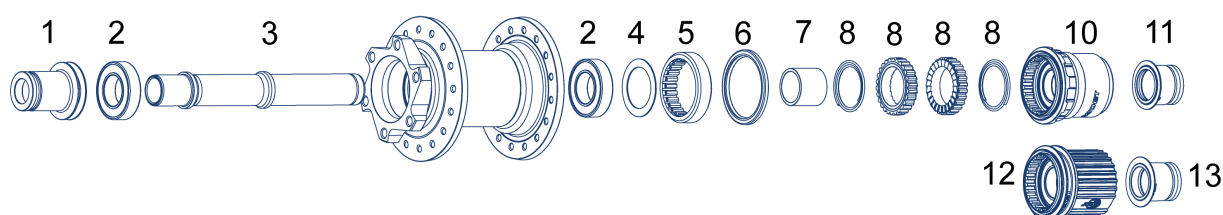

	DESCRIPTION	QTÉ PAR MOYEU	N° D'ARTICLE DT SWISS	N° D'ARTICLE ORBEA
1	RW ADAPT WP XXX/12 L B	1	HWA00100S7841S	XC17
2	B.BEARING 6902 ESB/ESNB L	2	HSBXXX00N2336S	XC06
3	RW AXLE AL 148MM Ø15/48.2MM	1	HCCXXX00S6450S	XC24
4	SHIM RING Ø28/20X0.5MM	1	HCDXXX00S1083S	XC23
5	RING NUT STEEL M34X1 240	1	HXDXXX00N1131S	XC22
6	SEAL HUB/ROTOR (Ø30x36x2.5 mm)	1	HSOXXX00N1031S	XB92
7	SPACER ALLOY 15.4 mm BL	1	HCDXXX00S1077S	XC21
8	SERVICE KIT RATCHET 24T	1	HWTXXX00NSKTFS	XC36
10	FB W MHY SRA XD RAT ST ST SL B	1	HWRAXL00S3224S	XC40
11	RW ADAPT WP XXX/12 R B SRAM XD	1	HWA00100S7513S	XC25
12	FB W MHY SHI MS RAT ST ST SL B	1	HWRABL00S3226S	XC34
13	RW ADAPT WP XXX/12 R B MS	1	HWA00100S7912S	XC15

	DESCRIPTION	N° D'ARTICLE DT SWISS	N° D'ARTICLE ORBEA
Pâte d'assemblage	Graisse universelle DT Swiss 20 g	HXTXXX00NMG20S	XB72
	Graisse spéciale DT Swiss 20 g	HXT10032508S	XB97
Outillage	Outil d'installation pour joint de moyeu	HXTXXX00N1000S	XC02
	Outil pour bague de cliquet fileté	HXTXXX00N5027S	XC32
	Douille courte de montage Ø15 / 28 x 35 mm	HXTXXX00N5024S	XC41

Cliquez sur la référence pour acheter la pièce en ligne. Les pièces de rechange pour les moyeux sont disponibles exclusivement chez les revendeurs Orbea via Kide (accès B2B)

## RAYONS. JEUX DE RAYONS POUR ROUE OQUO

## MOUNTAIN PERFORMANCE (MP)

MODÈLE DE ROUE	AVANT/ARRIÈRE	MOYEU	DESCRIPTION DE LA PIÈCE DE RECHANGE	INCLUT	QTÉ	CODE ART. ORBEA
MP30 LTD V1 jusqu'à l'année-modèle 2024	AVANT 29" 24 TROUS	DT SWISS 240 CLASSIC 24 TROUS	JEU DE RAYONS +EMBOUITS MP30 LTD AVANT 24 TROUS V1	Sapim CX-Ray TCS Aero. 14G (2 mm). Coudé. 293 mm Noir	2	XB61
				Sapim CX-Ray TCS Aero. 14G (2 mm). Coudé. 291 mm Noir	2	
				Sapim Alloy Double Square 2 x 18 mm. Noir	4	
	AVANT 29" 28 TROUS	DT SWISS 240 CLASSIC 28 TROUS	JEU DE RAYONS +EMBOUITS MP30 LTD AVANT 28 TROUS V1	Sapim CX-Ray TCS Aero. 14G (2 mm). Coudé. 299 mm Noir	2	XB65
				Sapim CX-Ray TCS Aero. 14G (2 mm). Coudé. 297 mm Noir	2	
				Sapim Alloy Double Square 2 x 18 mm. Noir	4	
	ARRIÈRE 29" 28 TROUS	DT SWISS 240 CLASSIC 28 TROUS	JEU DE RAYONS +EMBOUITS MP30 LTD ARRIÈRE 28 TROUS V1	Sapim CX-Ray TCS Aero. 14G (2 mm). Coudé. 295 mm Noir	2	XB86
				Sapim CX-Ray TCS Aero. 14G (2 mm). Coudé. 296 mm Noir	2	
				Sapim Alloy Double Square 2 x 18 mm. Noir	4	
MP30 LTD V2 à partir de l'année-modèle 2025	AVANT 29" 24 TROUS	OQUO LTD SP DT SWISS INSIDE 240 24 TROUS	JEU DE RAYONS +EMBOUITS MP30 LTD AVANT 24 TROUS V2	Droits en T DT aerolite 2,0-(0,9x2,2)-2 mm. 301 mm. Noir	4	XH58
				DT carré double alliage 2x15 mm.	4	
	ARRIÈRE 29" 28 TROUS	OQUO LTD SP DT SWISS INSIDE 240 28 TROUS	JEU DE RAYONS +EMBOUITS MP30 LTD ARRIÈRE 28 TROUS V2	Droits en T DT aerolite 2,0-(0,9x2,2)-2 mm. 304 mm. Noir	4	XH59
				DT carré double alliage 2x15 mm.	4	
MP30 TEAM V1 jusqu'à l'année-modèle 2024	AVANT 29" 28 TROUS	DT SWISS 350 CLASSIC 28 TROUS	JEU DE RAYONS +EMBOUITS MP30 TEAM AVANT 28 TROUS V1	Sapim D-Sprint. Butted 14G (2 mm) coudé 298 mm Noir	2	XC03
				Sapim D-Sprint. Butted 14G (2 mm) coudé 297 m Noir	2	
				Sapim Brass Polyax 2 x 14 mm. Noir	4	
	ARRIÈRE 29" 28 TROUS	DT SWISS 350 CLASSIC 28 TROUS	JEU DE RAYONS +EMBOUITS MP30 TEAM ARRIÈRE 28 TROUS V1	Sapim D-Sprint. Butted 14G (2 mm) coudé 294 m Noir	2	XC12
				Sapim D-Sprint. Butted 14G (2 mm) coudé 295 m Noir	2	
				Sapim Brass Polyax 2 x 14 mm. Noir	4	
MP30 TEAM V2 à partir de l'année-modèle 2025	AVANT 29" 28 TROUS	OQUO TEAM SP DT SWISS INSIDE 350 28 TROUS	JEU DE RAYONS +EMBOUITS MP30 TEAM AVANT 28 TROUS V2	Sapim Sprint SP Butted 2,0/1,7/2,0 305 mm. Noir	4	XH61
				Sapim Alloy Double Square 2 x 18 mm. Noir	4	
	ARRIÈRE 29" 28 TROUS	OQUO TEAM SP DT SWISS INSIDE 350 28 TROUS	JEU DE RAYONS +EMBOUITS MP30 TEAM ARRIÈRE 28 TROUS V2	Sapim Sprint SP Butted 2,0/1,7/2,0 304 mm. Noir	4	XH62
				Sapim Alloy Double Square 2 x 18 mm. Noir	4	
MP28 PRO (jusqu'à l'année-modèle 2023)	AVANT 29" 28 TROUS	DT SWISS 350 CLASSIC 28 TROUS	JEU DE RAYONS +EMBOUITS MP28 PRO AVANT 28 TROUS V1	Sapim Race. Butted 14G (2 mm) coudé 298 mm Noir	2	XC33
				Sapim Race. Butted. 14G (2 mm). Coudé. 297 mm Noir	2	
				Sapim Brass Polyax 2 x 14 mm. Noir	4	
	ARRIÈRE 29" 28 TROUS	DT SWISS 350 CLASSIC 28 TROUS	JEU DE RAYONS +EMBOUITS MP28 PRO ARRIÈRE 28 TROUS V1	Sapim Race. Butted 14G (2 mm) coudé 296 mm Noir	2	XC14
				Sapim Race. Butted. 14G (2 mm). Coudé. 297 mm Noir	2	
				Sapim Brass Polyax 2 x 14 mm. Noir	4	
MP28 PRO à partir de l'année-modèle 2024	AVANT 29" 28 TROUS	DT SWISS 370 CLASSIC 28 TROUS	JEU DE RAYONS +EMBOUITS MP28 PRO AVANT 28 TROUS V2	Sapim Race. Butted. 14G (2 mm). Coudé. 297 mm Noir	2	XD46
				Sapim Race. Butted. 14G (2 mm). Coudé. 296 mm Noir	2	
				Sapim Brass Polyax 2 x 14 mm. Noir	4	
	ARRIÈRE 29" 28 TROUS	DT SWISS 370 CLASSIC 28 TROUS	JEU DE RAYONS +EMBOUITS MP28 PRO ARRIÈRE 28 TROUS V2	Sapim Race. Butted. 14G (2 mm). Coudé. 296 mm Noir	2	XD47
				Sapim Race. Butted. 14G (2 mm). Coudé. 296 mm Noir	2	
				Sapim Brass Polyax 2 x 14 mm. Noir	4	

Cliquez sur la référence pour acheter la pièce en ligne.

## RAYONS. JEUX DE RAYONS POUR ROUE OQUO

## MOUNTAIN CONTROL (MC)

MODÈLE DE ROUE	AVANT/ARRIÈRE	MOYEU	DESCRIPTION DE LA PIÈCE DE RECHANGE	INCLUT	QTÉ	CODE ART. ORBEA
<b>MC32 LTD V1</b> jusqu'à l'année-modèle 2025	AVANT 29" 28 TROUS	DT SWISS 350 CLASSIC 28 TROUS	JEU DE RAYONS +EMBOUTS MC32 LTD AVANT 28 TROUS V1	Sapim D-Sprint. Butted 14G (2 mm) coudé 298 mm Noir	2	XC29
				Sapim D-Sprint. Butted. 14G (2 mm). Coudé. 301 mm. Noir	2	
				Sapim Brass Polyax 2 x 14 mm. Noir	4	
	ARRIÈRE 29" 32 TROUS	DT SWISS 350 CLASSIC 32 TROUS	JEU DE RAYONS +EMBOUTS MC32 LTD ARRIÈRE 32 TROUS V1	Sapim Race. Butted 14G (2 mm) coudé 292 mm Noir	4	XC30
			Sapim Brass Polyax 2 x 14 mm. Noir	4		
<b>MC32 LTD V2</b> à partir de l'année-modèle 2026	AVANT 29" 28 TROUS	OQUO LTD JBEND 28 TROUS DT INSIDE 350	JEU DE RAYONS +EMBOUTS MC32 LTD AVANT 28 TROUS V2	Sapim Sprint. Butted 14G (2 mm) coudé 299 mm Noir	4	XJ99
				Sapim Brass Polyax 2 x 14 mm. Noir	4	
	ARRIÈRE 29" 32 TROUS	OQUO LTD JBEND 32 TROUS DT INSIDE 350 DEG	JEU DE RAYONS +EMBOUTS MC32 LTD ARRIÈRE 32 TROUS V2	Sapim Race. Butted 14G (2 mm) coudé 291 mm Noir	4	XK00
				Sapim Brass Polyax 2 x 14 mm. Noir	4	
<b>MC32 TEAM V1</b> jusqu'à l'année-modèle 2024	AVANT 29" 28 TROUS	DT SWISS 350 CLASSIC 28 TROUS	JEU DE RAYONS +EMBOUTS MC32 TEAM AVANT 28 TROUS V1	Sapim D-Sprint. Butted 14G (2 mm) coudé 299 mm Noir	2	XC42
				Sapim D-Sprint. Butted. 14G (2 mm). Coudé. 297 m. Noir	2	
				Sapim Brass Polyax 2 x 14 mm. Noir	4	
	ARRIÈRE 29" 32 TROUS	DT SWISS 350 CLASSIC 32 TROUS	JEU DE RAYONS +EMBOUTS MC32 TEAM ARRIÈRE 29 32 TROUS V1	Sapim Race. Butted 14G (2 mm) coudé 291 mm Noir	4	XC43
				Sapim Brass Polyax 2 x 14 mm. Noir	4	
	ARRIÈRE 27,5" 32 TROUS	DT SWISS 350 CLASSIC 32 TROUS	JEU DE RAYONS +EMBOUTS MC32 TEAM ARRIÈRE 27,5 32 TROUS V1	Sapim Race. Butted 14G (2 mm) coudé 271 mm Noir	4	XC44
Sapim Brass Polyax 2 x 14 mm. Noir				4		
<b>MC32 TEAM V2</b> Anné-modèle 2025	AVANT 29" 28 TROUS	DT SWISS 350 CLASSIC 28 TROUS	JEU DE RAYONS +EMBOUTS MC32 TEAM AVANT 28 TROUS V2	Sapim D-Light Butted. 14G (2 mm). Coudé. 302 mm Noir	2	XH63
				Sapim D-Light Butted. 14G (2 mm). Coudé. 300 mm Noir	2	
				Sapim Alloy Double Square 2 x 18 mm. Noir	4	
	ARRIÈRE 29" 32 TROUS	DT SWISS 350 CLASSIC 32 TROUS	JEU DE RAYONS +EMBOUTS MC32 TEAM ARRIÈRE 29 32 TROUS V2	Sapim Sprint. Butted. 14G (2 mm) coudé 295 mm. Noir	4	XH64
				Sapim Alloy Double Square 2 x 18 mm. Noir	4	
	ARRIÈRE 27,5" 32 TROUS	DT SWISS 350 CLASSIC 32 TROUS	JEU DE RAYONS +EMBOUTS MC32 TEAM ARRIÈRE 27,5 32 TROUS V2	Sapim Sprint. Butted. 14G (2 mm). Coudé. 276 mm. Noir	4	XH65
Sapim Alloy Double Square 2 x 18 mm. Noir				4		
<b>MC32 TEAM V3</b> à partir de l'année-modèle 2026	AVANT 29" 28 TROUS	OQUO LTD JBEND 28 TROUS DT INSIDE 350	JEU DE RAYONS +EMBOUTS MC32 TEAM AVANT 28 TROUS V3	Sapim D-Light. Butted 14G (2 mm) coudé 298 mm Noir	2	XK02
				Sapim D-Light. Butted. 14G (2 mm). Coudé. 297 mm. Noir	2	
				Sapim Alloy Double Square 2 x 18 mm. Noir	4	
	ARRIÈRE 29" 32 TROUS	OQUO LTD JBEND 32 TROUS DT INSIDE 350 DEG	JEU DE RAYONS +EMBOUTS MC32 TEAM ARRIÈRE 29 32 TROUS V3	Sapim Sprint. Butted. 14G (2 mm). Coudé. 291 m. Noir	4	XK03
				Sapim Alloy Double Square 2 x 18 mm. Noir	4	
	ARRIÈRE 27,5" 32 TROUS	OQUO LTD JBEND 32 TROUS DT INSIDE 350 DEG	JEU DE RAYONS +EMBOUTS MC32 TEAM ARRIÈRE 27,5 32 TROUS V3	Sapim Sprint. Butted. 14G (2 mm). Coudé. 272 m. Noir	4	XK04
Sapim Alloy Double Square 2 x 18 mm. Noir				4		
<b>MC32 TEAM RALLON DH (OEM)</b> à partir de l'année-modèle 2026	AVANT 29" 28 TROUS	DT SWISS 350 CLASSIC 28 TROUS	JEU DE RAYONS +EMBOUTS MC32 TEAM RALLON DH AVANT 28 TROUS (OEM) V1	Sapim Race. Butted 14G (2 mm) coudé 296 mm Noir	4	XK05
				Sapim Brass Polyax 2 x 14 mm. Noir	4	
	ARRIÈRE 27,5" 32 TROUS	DT SWISS 350 CLASSIC 32 TROUS	JEU DE RAYONS +EMBOUTS MC32 TEAM RALLON DH ARRIÈRE 27,5 32 TROUS (OEM) V1	Sapim Race. Butted. 14G (2 mm). Coudé. 272 mm. Noir	4	XK06
				Sapim Brass Polyax 2 x 14 mm. Noir	4	

## RAYONS. JEUX DE RAYONS POUR ROUE OQUO

## MOUNTAIN CONTROL (MC) POWER

MODÈLE DE ROUE	AVANT/ ARRIÈRE	MOYEU	DESCRIPTION DE LA PIÈCE DE RECHANGE	INCLUT	QTÉ	CODE ART. ORBEA
MC32 LTD POWER jusqu'à l'année-modèle 2023	ARRIÈRE 29" 32 TROUS	DT SWISS 350 HYBRID CLASSIC 32H up to MY2023	JEU DE RAYONS + EMBOUTS MC32 LTD POWER ARRIÈRE 32 TROUS V1	Sapim E-Light. Butted 14G (2 mm) coudé 292 mm Noir	2	XC31
				Sapim E-Light. Butted 14G (2 mm). Coudé. 294 mm Noir	2	
				Sapim Brass Polyax 2 x 14 mm. Noir	4	
MC32 LTD POWER à partir de l'année-modèle 2024	AVANT 29" 28 TROUS	DT SWISS 350 HYBRID CLASSIC 28H from MY2024	JEU DE RAYONS + EMBOUTS MC32 LTD POWER AVANT 28 TROUS V2	Sapim E-Light. Butted 14G (2 mm) coudé 298 mm Noir	2	XD49
				Sapim E-Light. Butted 14G (2 mm). Coudé. 299 mm Noir	2	
				Sapim Brass Polyax 2 x 14 mm. Noir	4	
	ARRIÈRE 29" 32 TROUS	DT SWISS 350 HYBRID CLASSIC 32H from MY2024	JEU DE RAYONS + EMBOUTS MC32 LTD POWER ARRIÈRE 32 TROUS V2	Sapim E-Light. Butted 14G (2 mm) coudé 292 m Noir	2	XD50
				Sapim E-Light. Butted 14G (2 mm). Coudé. 291 mm Noir	2	
				Sapim Brass Polyax 2 x 14 mm. Noir	4	
MC32 TEAM POWER V1 jusqu'à l'année-modèle 2023	AVANT 29" 32 TROUS	DT SWISS 350 HYBRID CLASSIC 32H up to MY2023	JEU DE RAYONS + EMBOUTS MC32 TEAM POWER AVANT 32 TROUS V1	Sapim E-Light. Butted 14G (2 mm) coudé 292 mm Noir	2	XC45
				Sapim E-Light. Butted. 14G (2 mm). Coudé. 294 m. Noir	2	
				Sapim Brass Polyax 2 x 14 mm. Noir	4	
	ARRIÈRE 29" 32 TROUS	DT SWISS 350 HYBRID CLASSIC 32H up to MY2023	JEU DE RAYONS + EMBOUTS MC32 TEAM POWER ARRIÈRE 32 TROUS V1	Sapim E-Light. Butted 14G (2 mm) coudé 291 mm Noir	2	XC49
				Sapim E-Light. Butted. 14G (2 mm). Coudé. 293 mm Noir	2	
				Sapim Brass Polyax 2 x 14 mm. Noir	4	
MC32 TEAM POWER V2 Année-modèle 2024	AVANT 29" 28 TROUS	DT SWISS 350 HYBRID CLASSIC 28H from MY2024	JEU DE RAYONS + EMBOUTS MC32 TEAM POWER AVANT 28 TROUS V2	Sapim E-Light. Butted 14G (2 mm) coudé 297 m Noir	2	XD51
				Sapim E-Light. Butted 14G (2 mm) coudé 298 mm Noir	2	
				Sapim Brass Polyax 2 x 14 mm. Noir	4	
	ARRIÈRE 29" 32 TROUS	DT SWISS 350 HYBRID CLASSIC 32H from MY2024	JEU DE RAYONS + EMBOUTS MC32 TEAM POWER ARRIÈRE 29 32 TROUS V2	Sapim E-Light. Butted 14G (2 mm) coudé 291 mm Noir	2	XD52
				Sapim E-Light. Butted 14G (2 mm) coudé 292 mm Noir	2	
				Sapim Brass Polyax 2 x 14 mm. Noir	4	
	ARRIÈRE 27,5" 32 TROUS	DT SWISS 350 HYBRID CLASSIC 32H from MY2024	JEU DE RAYONS + EMBOUTS MC32 TEAM POWER ARRIÈRE 27,5 32 TROUS V2	Sapim E-Light. Butted 14G (2 mm) coudé 271 mm Noir	4	XD54
				Sapim Brass Polyax 2 x 14 mm. Noir	4	
	MC32 TEAM POWER V3 Année-modèle 2025	AVANT 29" 28 TROUS	DT SWISS 350 HYBRID CLASSIC 28H from MY2024	JEU DE RAYONS + EMBOUTS MC32 TEAM POWER FRONT 28 TROUS V3-V4	Sapim E-Light. Butted. 14G (2 mm). Coudé. 301 mm. Noir	2
Sapim E-Light. Butted. 14G (2 mm). Coudé. 300 mm. Noir					2	
Embouts anodisés Oquo 2 x 18 mm. + rondelles					4	
ARRIÈRE 29" 32 TROUS		DT SWISS 350 HYBRID CLASSIC 32H from MY2024	JEU DE RAYONS + EMBOUTS MC32 TEAM POWER ARRIÈRE 29 32 TROUS V3-V4	Sapim E-Light. Butted. 14G (2 mm). Coudé. 294 mm. Noir	2	XH72
				Sapim E-Light. Butted. 14G (2 mm). Coudé. 295 mm. Noir	2	
				Embouts anodisés Oquo 2 x 18 mm. + rondelles	4	
ARRIÈRE 27,5" 32 TROUS		DT SWISS 350 HYBRID CLASSIC 32H from MY2024	JEU DE RAYONS + EMBOUTS MC32 TEAM POWER ARRIÈRE 27,5 32 TROUS V3-V4	Sapim E-Light. Butted. 14G (2 mm). Coudé. 276 mm. Noir	2	XH73
				Sapim E-Light. Butted. 14G (2 mm). Coudé. 275 mm. Noir	2	
				Embouts anodisés Oquo 2 x 18 mm. + rondelles	4	

Cliquez sur la référence pour acheter la pièce en ligne.

## RAYONS. JEUX DE RAYONS POUR ROUE OQUO

## MOUNTAIN CONTROL (MC) POWER

MODÈLE DE ROUE	AVANT/ARRIÈRE	MOYEU	DESCRIPTION DE LA PIÈCE DE RECHANGE	INCLUT	QTÉ	CODE ART. ORBEA
MC32 TEAM POWER V4 à partir de l'année-modèle 2026	AVANT 29" 28 TROUS	DT SWISS 350 HYBRID CLASSIC 28H from MY2024	JEU DE RAYONS + EMBOUTS MC32 TEAM POWER FRONT 28 TROUS V3-V4	Sapim E-Light. Butted. 14G (2 mm). Coudé. 301 mm. Noir	2	XH71
				Sapim E-Light. Butted. 14G (2 mm). Coudé. 300 mm. Noir	2	
				Embouts anodisés Oquo 2 x 18 mm. + rondelles	4	
	ARRIÈRE 29" 32 TROUS	DT SWISS 350 HYBRID CLASSIC 32H from MY2024	JEU DE RAYONS + EMBOUTS MC32 TEAM POWER ARRIÈRE 29 32 TROUS V3-V4	Sapim E-Light. Butted. 14G (2 mm). Coudé. 294 mm. Noir	2	XH72
				Sapim E-Light. Butted. 14G (2 mm). Coudé. 295 mm. Noir	2	
				Embouts anodisés Oquo 2 x 18 mm. + rondelles	4	
	ARRIÈRE 27,5" 32 TROUS	DT SWISS 350 HYBRID CLASSIC 32H from MY2024	JEU DE RAYONS + EMBOUTS MC32 TEAM POWER ARRIÈRE 27,5 32 TROUS V3-V4	Sapim E-Light. Butted. 14G (2 mm). Coudé. 276 mm. Noir	2	XH73
				Sapim E-Light. Butted. 14G (2 mm). Coudé. 275 mm. Noir	2	
				Embouts anodisés Oquo 2 x 18 mm. + rondelles	4	

Cliquez sur la référence pour acheter la pièce en ligne.

## VALVES TUBELESS OQUO

### Installation de la valve tubeless sur des jantes asymétriques

Pour certaines jantes OQUO à profil asymétrique, il est nécessaire d'utiliser l'adaptateur asymétrique entre la jante et l'écrou de la valve afin que l'ensemble de la valve soit placé correctement à l'extérieur de la jante.

L'adaptateur est inclus avec des roues OQUO à profil asymétrique qui en ont besoin.

Consultez le tableau des longueurs de valves dans la section suivante pour voir les modèles de roue OQUO qui requièrent la pose de l'adaptateur de valve asymétrique.

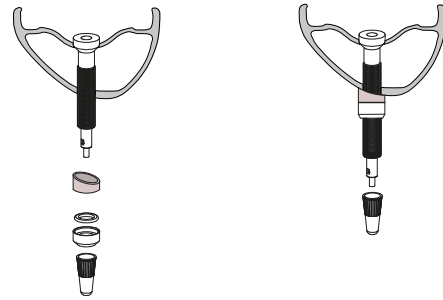

### Longueur de valve Tubeless

Consultez le tableau ci-dessous pour connaître la longueur de la valve Tubeless de vos roues OQUO.

GAMME	MODÈLE DE ROUE	LONGUEUR DE LA VALVE		ADAPTATEUR DE VALVE ASYMÉTRIQUE
		Avant	Arrière	
MOUNTAIN PERFORMANCE	MP30LTD	44 mm	44 mm	NON
	MP30TEAM	44 mm	44 mm	NON
	MP28PRO	40 mm	40 mm	OUI XB66
MOUNTAIN CONTROL	MC32LTD	44 mm	44 mm	NON
	MC32LTD POWER	44 mm	44 mm 57 mm sur l'extension avec aimant de valve	NON
	MC32TEAM V1 (jusqu'à l'année-modèle 2024)	44 mm	44 mm	OUI XB66
	MC32TEAM V2-V3 (à partir de l'année-modèle 2025)	44 mm	44 mm	OUI XH67
	MC32 TEAM RALLON DH (à partir de l'année-modèle 2026)	44 mm	44 mm	OUI XH67
	MC32 TEAM POWER V1 (jusqu'à l'année-modèle 2023)	44 mm	44 mm 57 mm sur l'extension avec aimant de valve	OUI XB66
	MC32 TEAM POWER V2-V4 (à partir de l'année-modèle 2024)	44 mm	44 mm 57 mm sur l'extension avec aimant de valve	OUI XH67



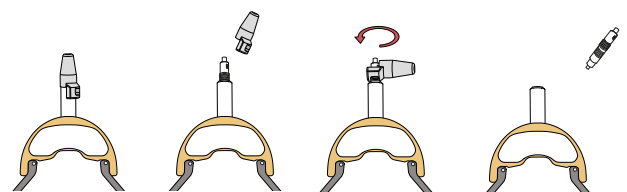

Cliquez sur la référence pour acheter la pièce en ligne.

### Outil intégré dans le capuchon de valve OQUO

Les valves Tubeless OQUO possèdent dans le capuchon un outil de dépose de l'embout de la valve.

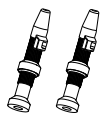
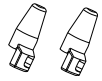

## Accessoires OQUO

N° D'ARTICLE	DESCRIPTION	QTÉ	
X803	<b>KIT DE VALVE TUBELESS OQUO 44 mm</b> Avec outil de dépose d'embout de valve	2	
X804	<b>KIT DE VALVE TUBELESS OQUO 44 mm + 57 mm</b> Avec outil de dépose d'embout de valve N'inclut pas d'adaptateur pour jantes asymétriques		
XB67	<b>KIT DE VALVE TUBELESS OQUO</b> Outil de dépose d'embout de valve intégré	2	
XB66	<b>KIT D'ADAPTATEUR DE VALVE DE JANTE ASYMÉTRIQUE V1</b> Vérifiez le tableau de la section précédente pour voir si vos roues OQUO ont besoin d'un adaptateur	2	
XH67	<b>KIT D'ADAPTATEUR DE VALVE DE JANTE ASYMÉTRIQUE V2</b> Vérifiez le tableau de la section précédente pour voir si vos roues OQUO ont besoin d'un adaptateur	2	
XH28	<b>KIT DE FERMETURE DE VALVE OQUO</b>	10	

Cliquez sur la référence pour acheter la pièce en ligne.

---

## MONTAGE DE ROUE OQUO



Cette rubrique fournit des informations générales sur le rayonnage et la finition des roues OQUO aux revendeurs OQUO qui doivent remplacer une jante OQUO après avoir reçu l'autorisation d'OQUO. Il ne s'agit pas d'un manuel de montage de roue de vélo.

Le montage correct et sûr d'une roue requiert des connaissances techniques poussées et de l'expérience. Les utilisateurs ou les mécaniciens qui n'ont pas suivi la formation adéquate ou qui ne possèdent pas l'expérience requise doivent s'abstenir de monter des roues en vue d'une utilisation.



Le montage incorrect d'une roue peut compromettre l'intégrité structurelle et la durabilité de la roue. Il pourrait provoquer une défaillance du composant non couverte par la garantie, ce qui pourrait entraîner des blessures graves, voire mortelles.

### OUTILLAGE

Veillez consulter la rubrique Entretien des roues OQUO où vous trouverez une description des outils requis pour l'entretien et le montage corrects des roues OQUO.

Utilisez toujours les outils et les produits adéquats lors du montage d'une roue. L'utilisation d'outils mal adaptés ou en mauvais état ou de produits génériques peut endommager les composants et ces dégâts ne sont pas couverts par la garantie.

## JANTES ASYMÉTRIQUES

Si la jante possède un profil asymétrique (consultez le tableau des caractéristiques techniques dans ce manuel pour connaître les modèles qui utilisent une jante asymétrique), veillez à toujours orienter la jante conformément aux instructions ci-après.

- **Jantes avant**

Le déport de jante doit être orienté vers le côté transmission

- **Jantes arrière**

Le déport de jante doit être orienté vers le côté opposé à la transmission.

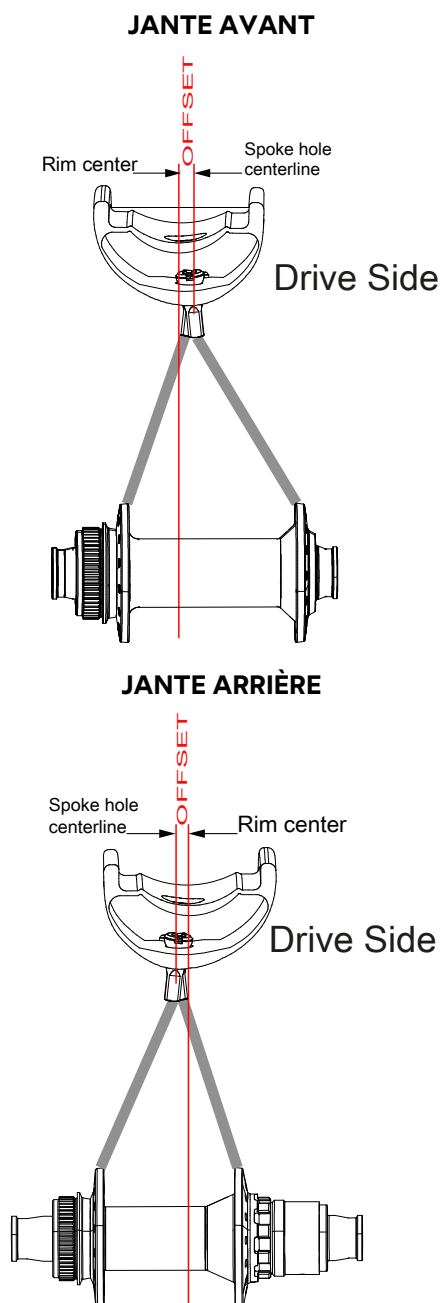

## JANTES SYMÉTRIQUES

Pour les jantes symétriques (sans déport), orientez la jante de telle sorte que les décalcomanies ou les autocollants puissent être lus depuis le même côté du vélo que sur la roue d'origine.

## TROUS DE RAYON DIRECTIONNELS

Si la jante possède des trous de rayon directionnels, montez la roue de sorte que l'orientation des trous de la jante corresponde au côté du moyeu adéquat.

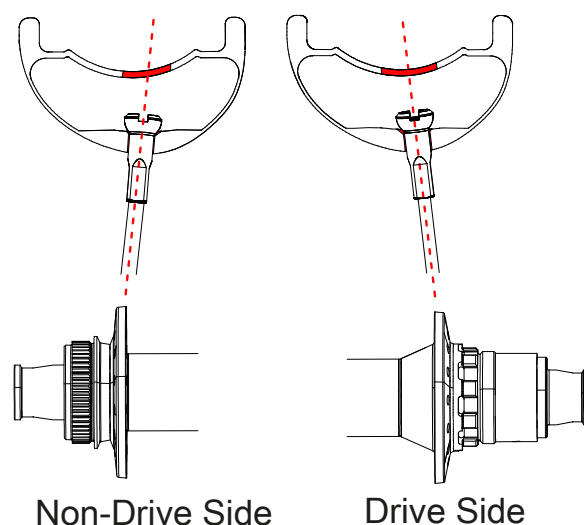

## JANTES SPÉCIFIQUES POUR ROUE AVANT ET ARRIÈRE

Sur les modèles de roue OQUO dotés d'une jante spécifique pour roue avant ou arrière, veillez à utiliser la jante spécifique conçue pour cette roue.

Le tableau des caractéristiques techniques de ce manuel permet de confirmer si votre modèle de roue utilise des jantes spécifiques pour roue avant ou arrière.

Le nom des modèles de jantes prévues pour la roue avant contient la lettre F.

Le nom des modèles de jantes prévues pour la roue arrière contient la lettre R.

Le nom des modèles de jantes qui ne sont pas prévues spécialement pour la roue avant ou arrière contient la lettre B.

## RAYONS ET EMBOUTS

Utilisez toujours les modèles de rayon et d'embout indiqués par OQUO pour le modèle de roue.

Vous pouvez vérifier les composants de chaque modèle dans le tableau des caractéristiques techniques de ce manuel.

### RAYONS DROITS CLASSIQUES OU EN T

Il faut monter des rayons droits classiques ou en T, en fonction du logement pour la tête de rayon sur un moyeu straightpull.

Sur un moyeu avec rayons droits en T, le logement de la tête de rayon est rectangulaire. Il accueille complètement la tête de rayon et empêche que celle-ci se torde ou se desserre.

Sur les moyeux à rayons droits classiques, le logement de la tête de rayon est rond, ce qui signifie que le rayon doit avoir une tête standard.

### RAYONS DROITS EN T



### EMBOUTS AVEC RONDELLES DE RENFORT

Certains embouts utilisent des rondelles de renfort placées entre l'embout et la jante.

Vérifiez le tableau des caractéristiques techniques de la roue afin de voir s'il faut monter des rondelles de renfort.

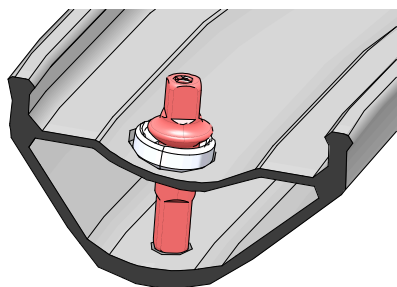

## RAYONNAGES AVEC RAYONS COUDÉS



À la différence des assemblages avec rayons cou-  
dés, le rayonnage dans les assemblages avec des  
rayons droits est déterminé par le moyeu. Il ne peut  
être choisi au moment d'assembler la roue.

Veillez à toujours monter la roue en respectant le  
rayonnage d'origine de chaque côté de la roue.

Assurez-vous que les rayons se croisent correctement  
(au-dessus ou en-dessous).

### 3 RAYONS CROISÉS

Chaque rayon croise trois autres rayons du même côté  
de la roue avant d'être fixé à la jante.

Selon le côté de la bride du moyeu d'où sort le rayon, il  
existe deux positions possibles par rapport aux trois  
autres rayons.

Si le rayon sort du côté extérieur de la bride du moyeu,  
la position par rapport aux rayons qu'il croise doit être :

- 01 Dessus
- 02 Dessus
- 03 Dessous

Si le rayon sort du côté intérieur de la bride du moyeu,  
la position par rapport aux rayons qu'il croise doit être :

- 01 Dessous
- 02 Dessous
- 03 Dessus

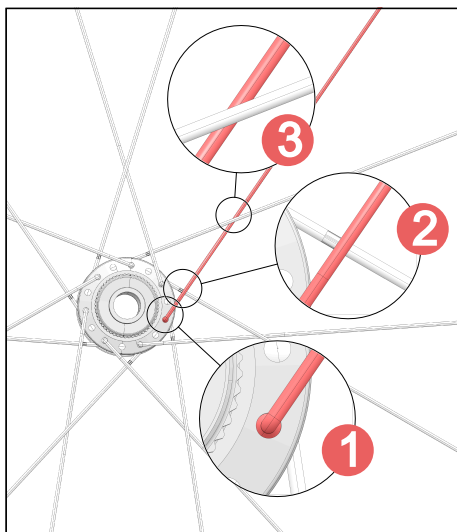

## 2 RAYONS CROISÉS

Chaque rayon croise deux autres rayons du même côté  
de la roue avant d'être fixé à la jante.

Selon le côté de la bride du moyeu d'où sort le rayon, il  
existe deux positions possibles par rapport aux deux  
autres rayons.

Si le rayon sort du côté extérieur de la bride du moyeu,  
la position par rapport aux rayons qu'il croise doit être :

- 01 Dessus
- 02 Dessous

Si le rayon sort du côté intérieur de la bride du moyeu,  
la position par rapport aux rayons qu'il croise doit être :

- 01 Dessous
- 02 Dessus

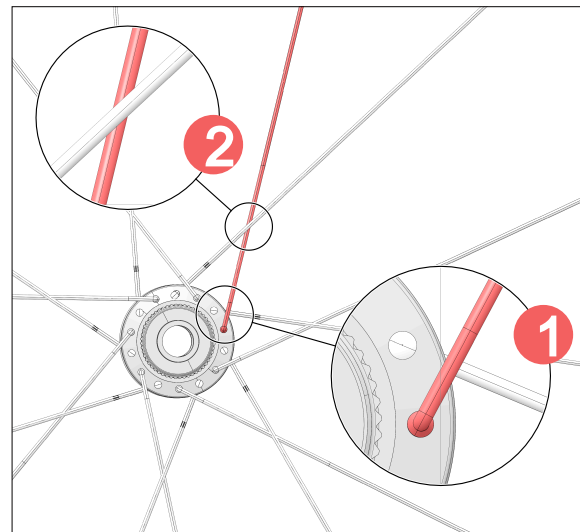

## POSITION DES RAYONS COUDÉS DE TÊTE ET DE QUEUE



Dans les assemblages avec moyeu straightpull et rayons droits, la position des rayons et du moyeu est unique et elle ne peut être définie au moment d'assembler la roue.

Vérifiez la position des rayons de tête et de queue dans le tableau des caractéristiques techniques de ce manuel ou sur la roue d'origine, puis reproduisez le rayonnage des deux côtés de la roue.

### Rayon de queue

Rayons qui sortent du moyeu dans la direction opposée à la rotation de la roue.

### Rayon de tête

Rayons qui sortent du moyeu dans la même direction que celle de la rotation de la roue.

Les images ci-après illustrent des exemples de rayonnage. Vérifiez le rayonnage sur la roue d'origine ou dans le tableau des caractéristiques techniques.



Direction de la rotation de la roue

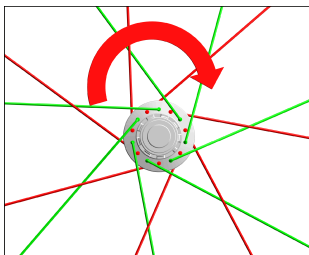

ROUES ARRIÈRE CÔTÉ TRANSMISSION

**En aval :** A l'extérieur du flasque du moyeu  
**En tête :** A l'intérieur du flasque du moyeu

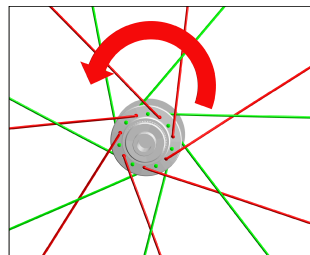

ROUES ARRIÈRE CÔTÉ OPPOSÉ À LA TRANSMISSION

**En aval :** A l'intérieur du flasque du moyeu  
**En tête :** A l'extérieur du flasque du moyeu

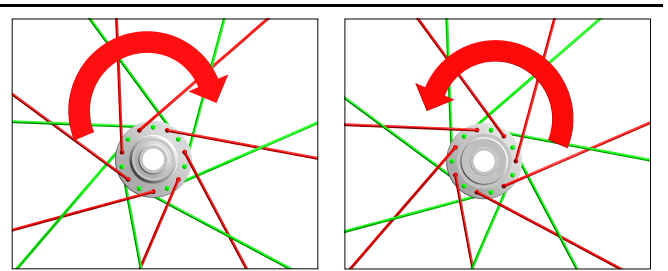

ROUES AVANT CÔTÉ TRANSMISSION

**En aval :** A l'intérieur du flasque du moyeu  
**En tête :** A l'extérieur du flasque du moyeu

ROUES AVANT CÔTÉ OPPOSÉ À LA TRANSMISSION

**En aval :** A l'intérieur du flasque du moyeu  
**En tête :** A l'extérieur du flasque du moyeu

## POSITION DE L'ORIFICE DE LA VALVE

L'orifice de la valve sur la jante doit se trouver entre deux rayons parallèles pour faciliter la pose du pneu.



### POSITION DU LOGO DU MOYEU

Pour des raisons esthétiques, si le corps du moyeu affiche un logo, la position du moyeu par rapport à la jante doit permettre d'aligner le logo du moyeu sur l'orifice de la valve sur la jante.

Ce point n'a aucun impact sur le fonctionnement de la roue. Un montage qui ne remplit pas cette condition est considéré comme étant valide, pour autant que tous les autres paramètres d'assemblage soient corrects.

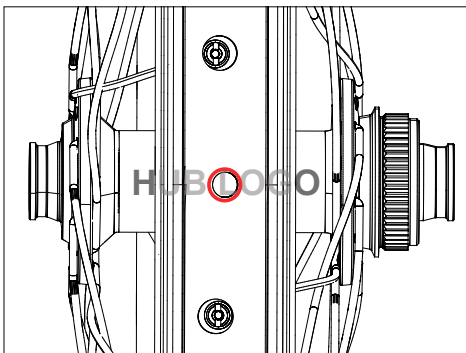

### MISE EN TENSION ET CENTRAGE

Le montage correct et sûr d'une roue requiert des connaissances techniques poussées et de l'expérience. Les utilisateurs ou les mécaniciens qui n'ont pas suivi la formation adéquate ou qui ne possèdent pas l'expérience requise doivent s'abstenir de monter des roues en vue d'une utilisation.



Ce manuel n'inclut pas des instructions complètes sur le rayonnage et la mise en tension des roues de vélo, mais bien des consignes générales sur la finition des roues OQUO et les tolérances admises. Il s'agit d'un guide générique sur le rayonnage et la finition des roues OQUO pour les revendeurs OQUO qui doivent remplacer une jante OQUO après avoir reçu l'autorisation d'OQUO. Il ne s'agit pas d'un manuel de montage de roue de vélo.



Le montage incorrect d'une roue peut compromettre l'intégrité structurelle et la durabilité de la roue. Il pourrait provoquer une défaillance du composant non couverte par la garantie, ce qui pourrait entraîner des blessures graves, voire mortelles.

Une fois que les rayons ont été posés avec les embouts sans mettre la roue en tension, passez au centrage de la roue dans le respect des tolérances décrites dans ce manuel. Augmentez la tension progressivement et équitablement. Réalisez les vérifications suivantes après avoir réglé quelques rayons.

OQUO recommande de vérifier l'alignement de la roue de la manière suivante :

- 01** Vérification de l'alignement latéral
- 02** Vérifiez le centrage radial
- 03** Vérifiez le centrage latéral sur les deux côtés de la roue.

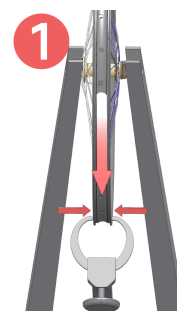

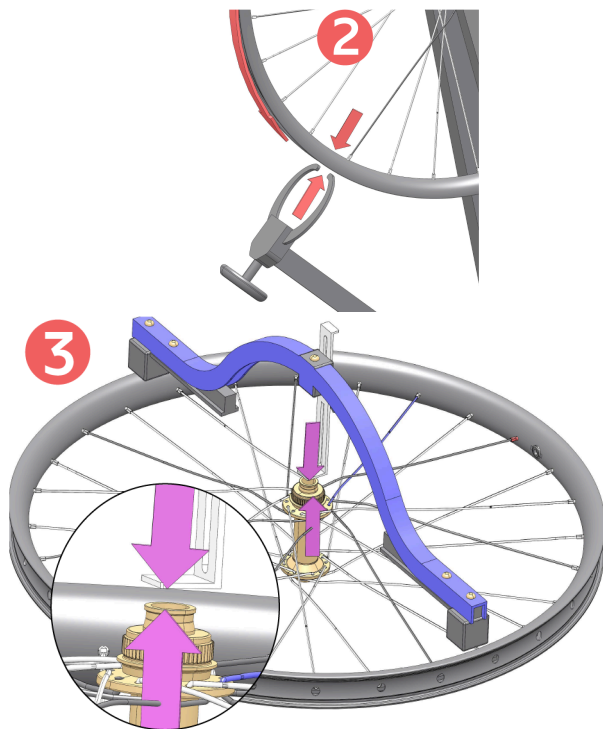

Répétez ces vérifications aussi souvent que nécessaire lors de la mise en tension des rayons chaque fois que vous augmentez la tension de plusieurs rayons et ce, dans le but d'éviter un voilement excessif qui pourrait endommager la jante.

#### ATTENTION

Après chaque vérification des alignements radial et latéral et de l'angle d'inclinaison de la roue, éliminez les contraintes de la roue pour permettre aux rayons de trouver leur position et d'éliminer les débattements et de conserver l'angle.

Pour éliminer les contraintes d'une roue, posez une extrémité du moyeu sur une surface solide, puis appuyez sur les côtés opposés de la jante avec les mains et appliquez le poids de votre corps.

Réalisez cette vérification des deux côtés de la roue.

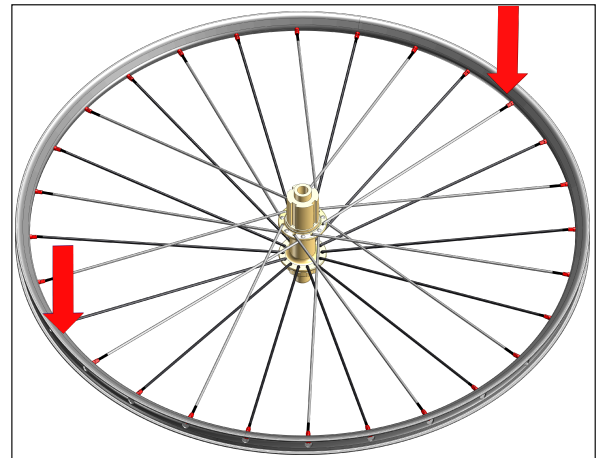

#### VÉRIFICATION DE LA TENSION DES RAYONS

Vérifiez la tension cible sur le côté le plus tendu de chaque roue pour votre modèle dans le tableau des caractéristiques techniques de ce manuel (rubrique consacrée aux rayons). Une fois que la tension cible sur le côté indiqué de la roue a été atteinte, et que les valeurs de débattement radial et axial et de l'angle d'inclinaison de la roue se trouvent dans les tolérances prescrites, la tension des rayons du côté moins tendu doit être uniforme.

Utilisez toujours un tensiomètre de qualité et vérifiez régulièrement son étalonnage conformément aux instructions du fabricant.

Suivez les instructions du fabricant pour utiliser le tensiomètre correctement et pouvoir interpréter comme il se doit les relevés en fonction des caractéristiques techniques des rayons.

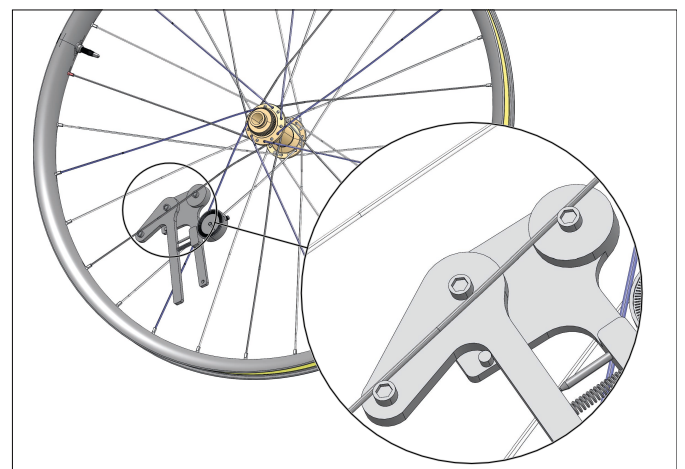

## PÂTE D'ASSEMBLAGE

Si vous effectuez un entretien ou un laçage sur l'une de nos roues, une fois que la roue est correctement centrée et tendue, nous recommandons l'utilisation d'un produit de blocage des rayons de force moyenne qui soit aussi fluide que possible sur les filets des rayons.

## INSTRUCTIONS ET TOLÉRANCES DE MONTAGE DE ROUE OQUO

TENSION CIBLE DE MONTAGE DE ROUE OQUO	
TENSION	<b>Vérifiez la tension cible sur le côté le plus tendu de chaque roue pour votre modèle dans le tableau des caractéristiques techniques de ce manuel (rubrique consacrée aux rayons).</b>
	Une fois que la tension cible sur le côté indiqué de la roue a été atteinte, et que les valeurs de débatement radial et latéral et de l'angle d'inclinaison de la roue se trouvent dans les tolérances prescrites, la tension des rayons du côté moins tendu doit être uniforme.
	<b>TOLÉRANCE DE TENSION MOYENNE DES RAYONS DU CÔTÉ LE PLUS TENDU DE LA ROUE</b>
	+/- 5 %

Utilisez toujours un tensiomètre de qualité et vérifiez régulièrement son étalonnage conformément aux instructions du fabricant. Suivez les instructions du fabricant pour utiliser le tensiomètre correctement et pouvoir interpréter comme il se doit les relevés en fonction des caractéristiques techniques des rayons.

VOILE		LATÉRAL	RADIAL	ANGLE D'INCLINAISON DE ROUE
	Aluminium	0,4 mm	0,6 mm	0,6 mm
Carbone	0,3 mm	0,6 mm	0,3 mm	

---

## INFORMATIONS SUPPLÉMENTAIRES

Trouvez de plus amples informations sur OQUO dans les réseaux sociaux

### FACEBOOK

[www.facebook.com/oquo.wheels](http://www.facebook.com/oquo.wheels)

### INSTAGRAM

[www.instagram.com/oquo.wheels/](http://www.instagram.com/oquo.wheels/)

### LINKEDIN

[www.linkedin.com/company/oquowheels/](http://www.linkedin.com/company/oquowheels/)

### YOUTUBE

[www.youtube.com/channel/UCpXzSOB\\_9oLzLzAnnwuaGCg](http://www.youtube.com/channel/UCpXzSOB_9oLzLzAnnwuaGCg)

### MANUELS

Téléchargez la dernière version du présent manuel, ainsi que tous les autres produits OQUO sur le site Internet :

[www.oquowheels.com/en-int/support/manuals](http://www.oquowheels.com/en-int/support/manuals)

### CONTACT

Si vous avez des questions relatives à nos produits, veuillez consulter :

[www.oquowheels.com/en-int/support/contact](http://www.oquowheels.com/en-int/support/contact)

---

**Orbea OQUO SL 2025**  
**Polígono Industrial Kareaga, 2. NAV 49,**  
**Markina-Xemein. 48270. Bizkaia**  
**T. 0034 943 171 950**

Tous droits réservés. La modification du présent document est interdite.

Le manuel technique du produit est fourni à titre informatif uniquement. Il concerne l'assemblage, l'installation et l'entretien dudit produit et, en tant que tel, peut faire l'objet de modifications des caractéristiques et/ou de mises à jour futures de ces informations par le fabricant. Son contenu n'a aucune valeur publicitaire ou contractuelle par rapport au produit décrit, et celui-ci ne doit pas être considéré par l'utilisateur comme un élément ayant une influence sur sa décision d'acheter le produit ou non. Par conséquent, nous ne pourrions en aucun cas être tenus comme responsables si l'utilisateur ou un tiers utilise ce manuel à des fins autres que celles prévues et spécifiées.

Tous droits réservés. La modification du présent document est interdite. Le contenu du présent manuel est sujet à modifications des spécifications sans préavis.

Pour obtenir la dernière version, veuillez consulter [www.oquowheels.com](http://www.oquowheels.com)